

# ASSEMBLY INSTRUCTIONS

Style# CH-4044 Velet

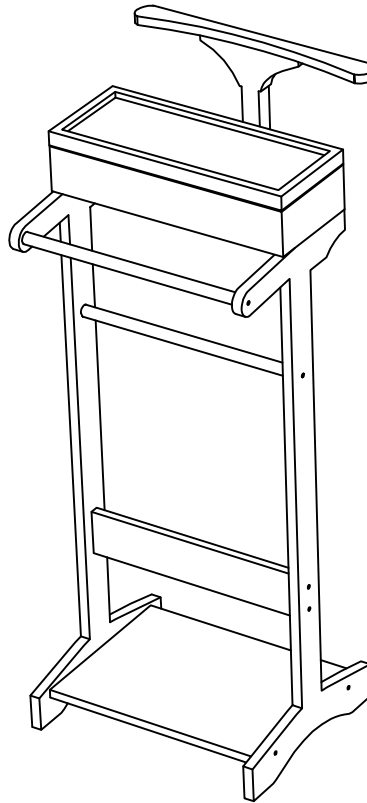

## NOTE TO CUSTOMERS:

- For ease and speed of assembly we recommend that before you commence each step of the assembly that you identify all the parts required to complete that step.
- We recommend that where possible you allow sufficient space to assemble the item as close as possible to the place where it will be once assembled.
- For the protection of your furniture we recommend that the product is placed on protected surfaces during assembly to prevent any damage.
- During assembly do not over tighten, as this may damage the product.
- Please ensure you retain all the product packaging until the item completely assembled.
- Please periodically check all fittings and re-tighten as necessary.
- Please never allow any liquids to remain on your furniture as absorption can cause the wood to warp or finish to de-laminate.
- It is recommended that this item should be assembled by two adults.

To use a cam lock:(Please read below instructions before assembling)

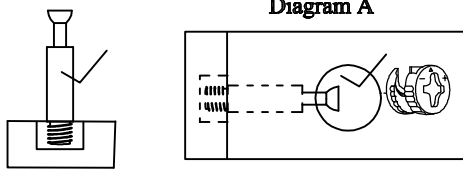

Diagram A

1.Insert cam screw into holes as shown in diagram A.

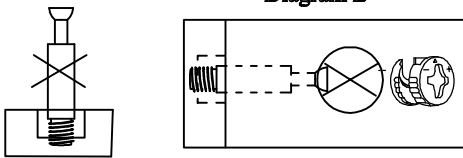

Diagram B

Make sure not to insert the cam screw too deep as shown in figure B, as this can lead to misalignment and prevent proper interlocking.

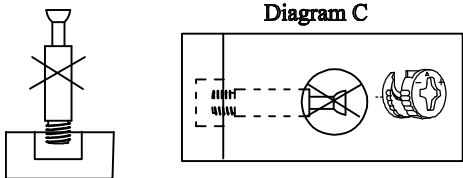
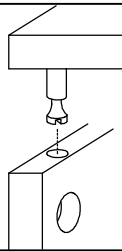
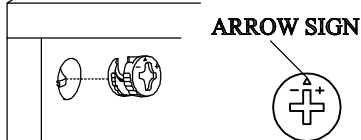

Diagram C

Also avoid inserting the cam screw too close to the surface as shown in figure C, since this can cause the cam lock to loosen and fail to interlock properly.



2.Connect the panels together.



3.When inserting the cam lock make sure the arrow of the cam lock faces the cam screw.

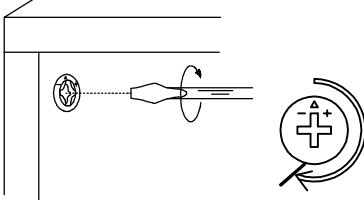





4.To tighten the cam lock, turn it clockwise by 90 to 180 degrees, or until the arrow points away from where the cam lock was inserted.

**NOTE:DO NOT USE AN AUTOMATIC SCREWDRIVER TO TIGHTEN CAM LOCKS.**

**Note:**

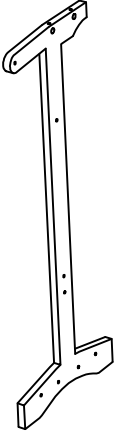
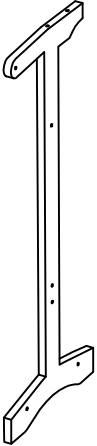
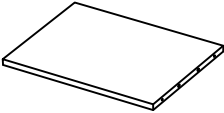
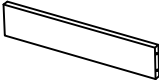
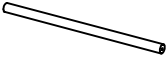
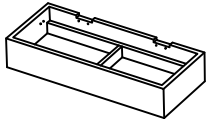
- Read these instructions carefully before assembling.
- Tools required:Phillips screwdriver, flat screwdriver.
- Find a clean, smooth area on which to work, such as a carpet, in order to avoid scratching the wood surface.
- Wait to dispose of the packing material until assembly is complete and all parts and hardware are accounted for.
- Two or more people might be required for assembly.
- Max weight capacity 20 LBS.

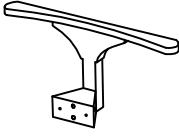
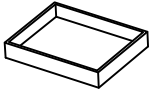





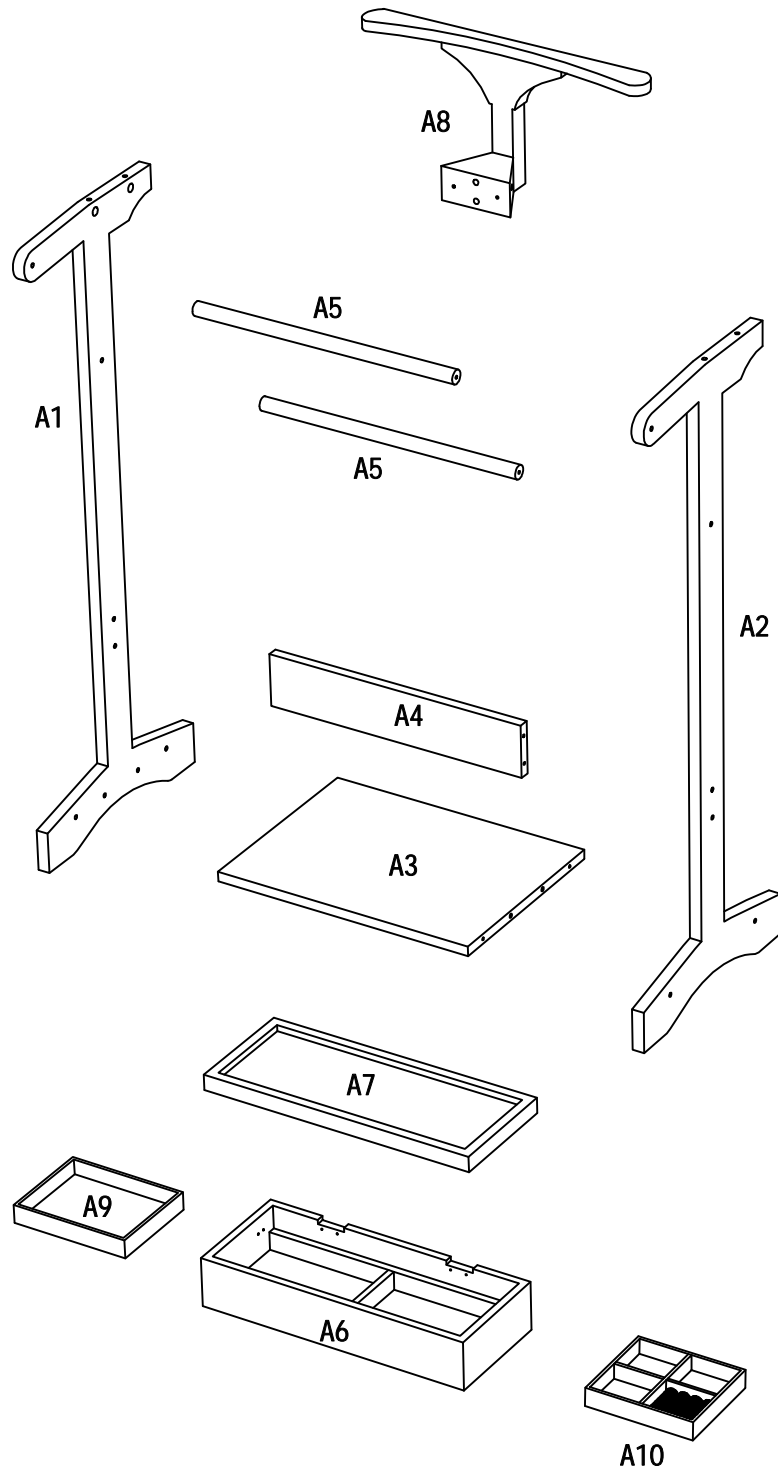

# Part List

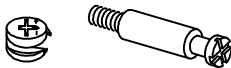
A1. Qty: 1    Left Leg	A2. Qty: 1    Right Leg	A3. Qty: 1    Bottom Panel	A4. Qty: 1    Apron
		A5. Qty: 1    Connect Bar	A6. Qty: 1    Box
A7. Qty: 1    Lip	A8. Qty: 1    Velvet Support	A9. Qty: 1    Box	A10. Qty: 1    Box

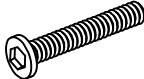
# Part List

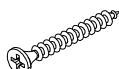

# Hardware List

B1. Qty: 4  Cam-lock	B2. Qty: 4  Wood Dowel	B3. Qty: 2  Bolt	B4. Qty: 1  Safety Hinge
B5. Qty: 2  Hinge	B6. Qty: 8  Screw	B7. Qty: 4  Screw	B8. Qty: 14  Screw
 Allen Wrench			

## APPENDIX: Dimension of Hardware in this AI

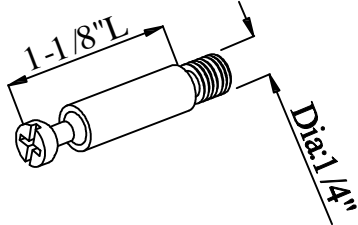
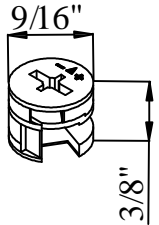
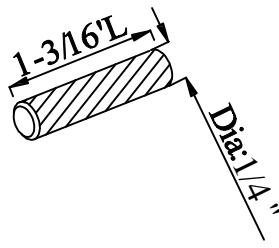
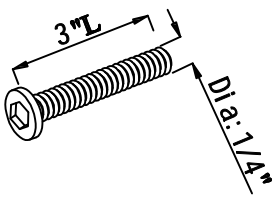
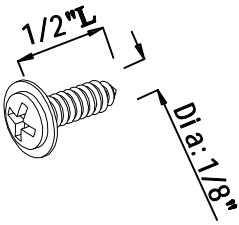
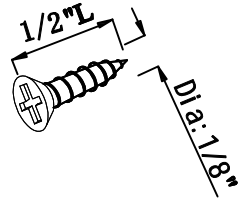
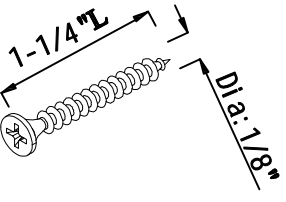
B1.  Cam-bol t	B1.  Cam-nut	B2.  Wood Dowel
B3.  Screw	B6.  Screw	B6.  Screw
B8.  Screw		

# ASSEMBLY INSTRUCTIONS

## Step: 1

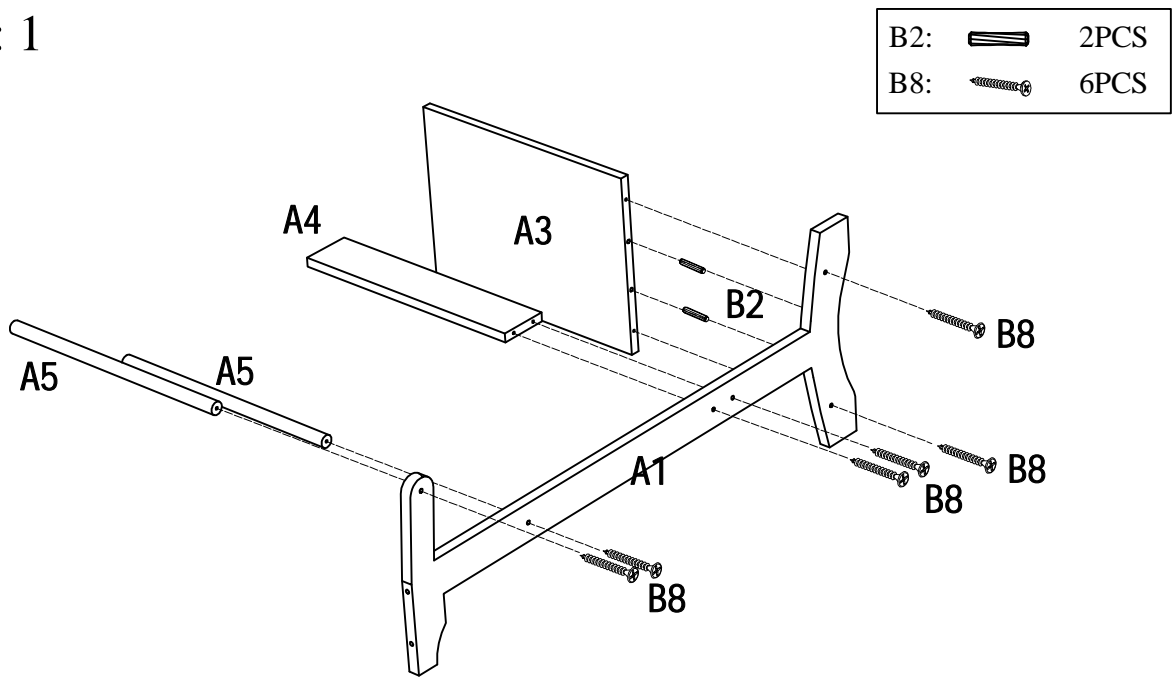

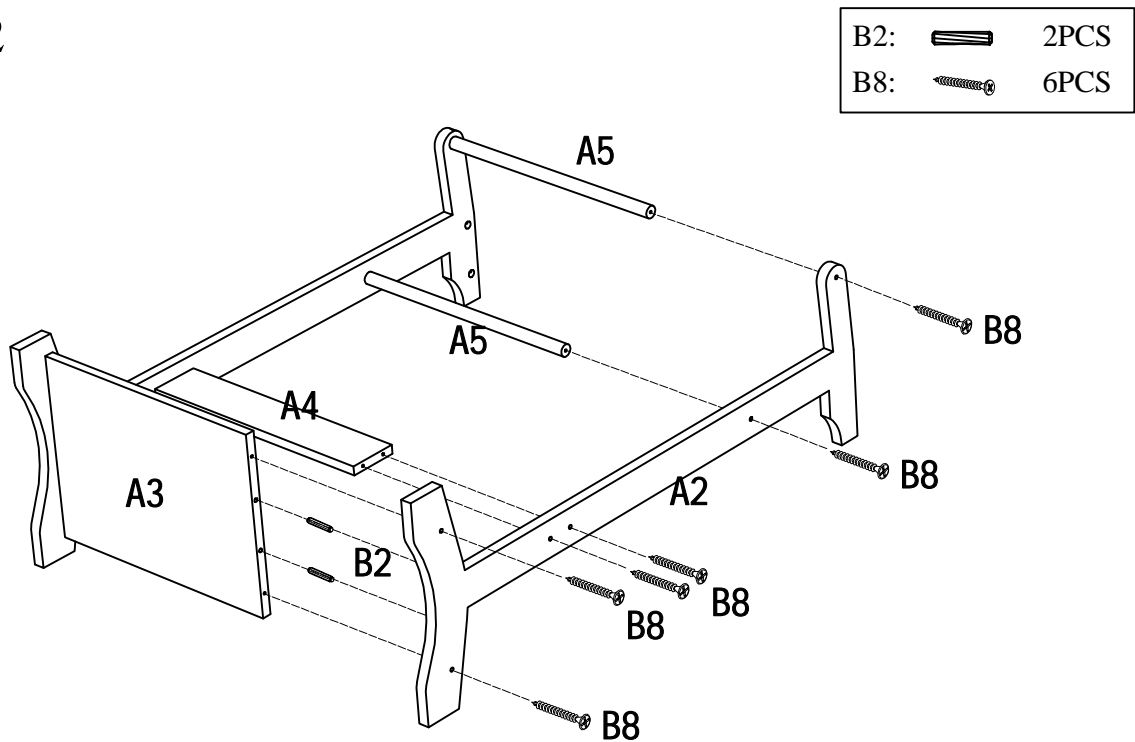

Assemble Bottom Panel A3 ,Apron A4 and Connect Bars A5 to Left Leg A1 using Wood Dowels B2 and Screws B8 as shown above.

## Step: 2



Assemble Bottom Panel A3 ,Apron A4 and Connect Bars A5 to Right Leg A2 using Wood Dowels B2 and Screws B8 as shown above.

### Step: 3

B5:		2PCS
B7:		4PCS

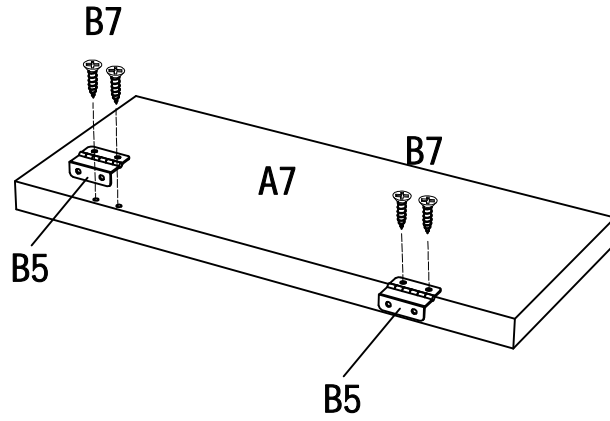

Assemble Hinges B5 to Lip A7 using Screws B7 as shown above.

### Step: 4

B6:		4PCS
-----	---	------

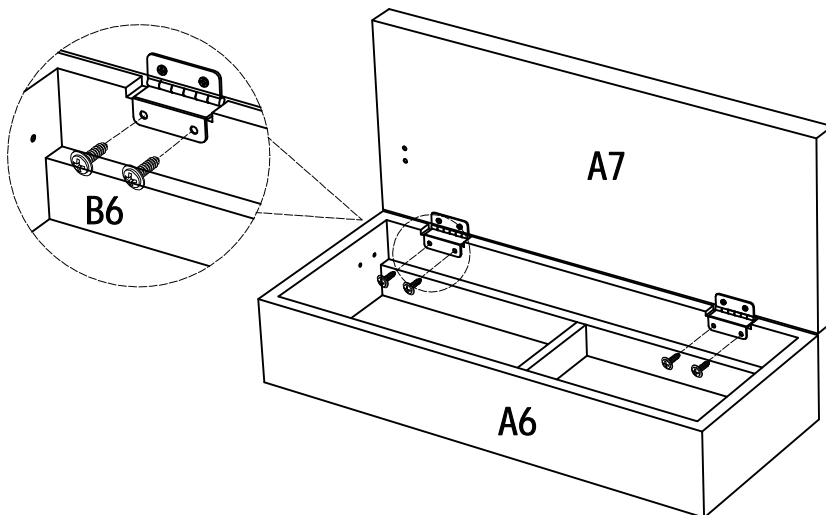

Assembly Lip A7 to Box A6 using Screws B6 as shown above.

## Step: 5

B4:  1PC  
B2:  4PCS

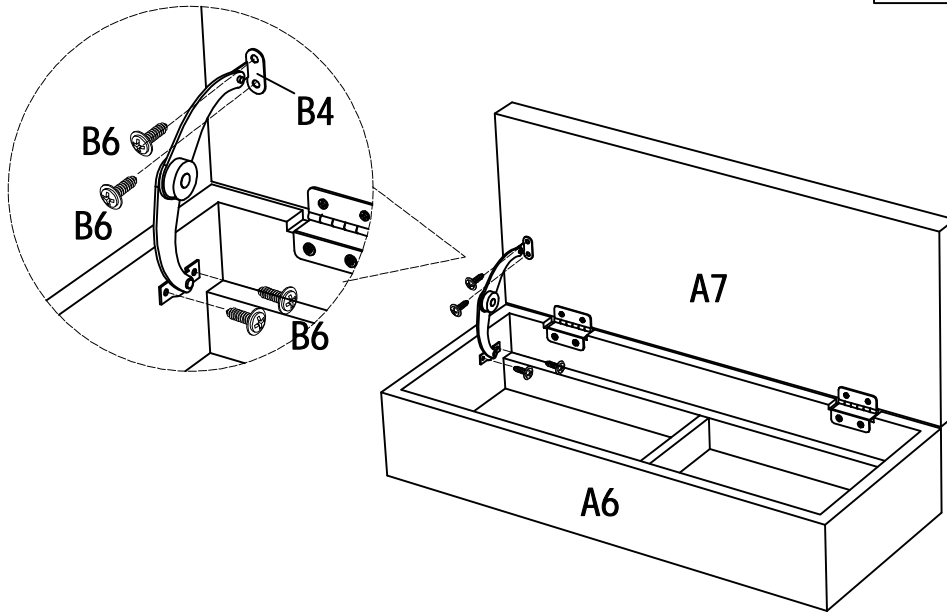

Attach Safety Hinge B4 to support the lip using Screws B6 as shown above.

## Step: 6

B1:  4SETS

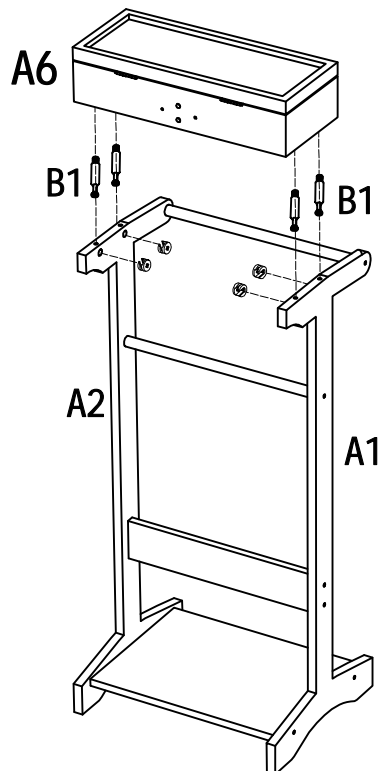



Assemble Box A6 to Legs A1&A2 using Cam-locks B1 using as shown above.

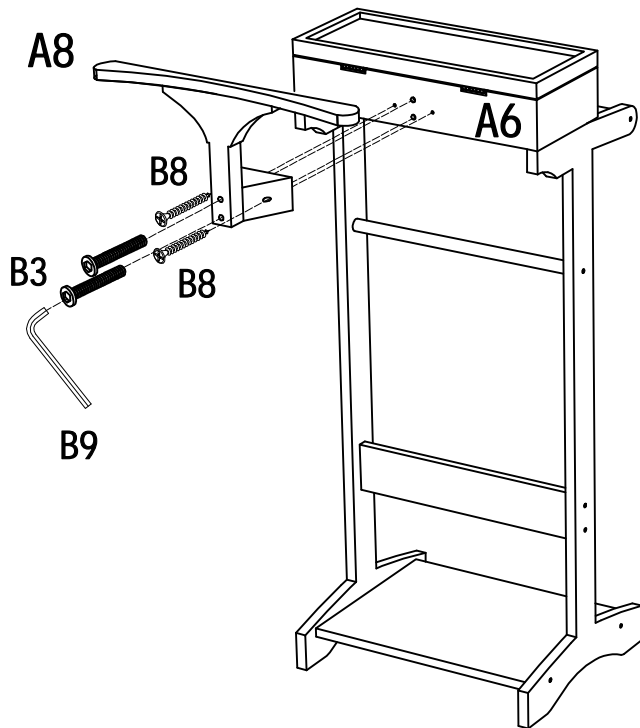

# Step: 7



B3:		2PCS
B8:		2PCS
		

Assemble Velvet Support A8 to the back of Box A6 using Screws B8 & Bolts B3 as shown above.

# Step: 8

