

ASSEMBLY INSTRUCTIONS

Style # 35 Step Stool

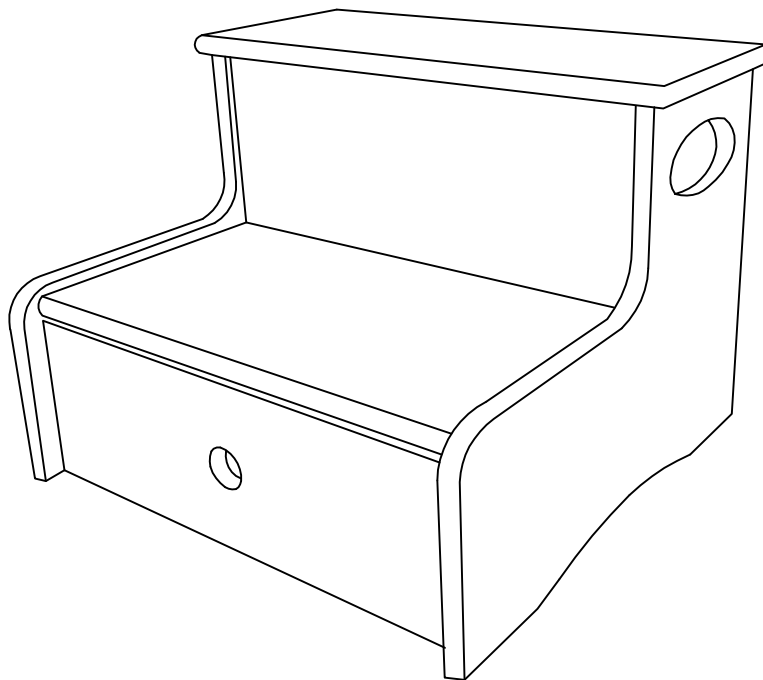

NOTE TO CUSTOMERS:

- For ease and speed of assembly we recommend that before you commence each step of the assembly that you identify all the parts required to complete that step.
- We recommend that where possible you allow sufficient space to assemble the item as close as possible to the place where it will be once assembled.
- For the protection of your furniture we recommend that the product is placed on protected surfaces during assembly to prevent any damage.
- During assembly do not over tighten ,as this may damage the product.
- Please ensure you retain all the product packaging until the item completely assembled.
- Please periodically check all fittings and re-tighten as necessary.
- Never allow any liquids to remain on your furniture as absorption can cause the wood to warp or the finish to de-laminate.
- It is recommended that this item should be assembled by two adults.

To insert a cam lock: (Please read below instructions before assembling)

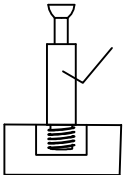
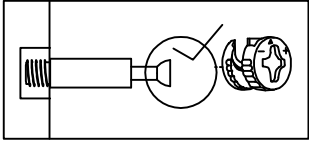
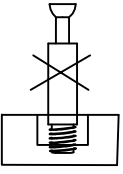
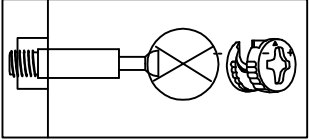
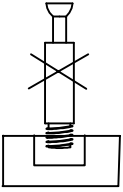
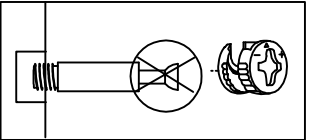
		<p>1. Insert cam screw into hole as shown in diagram A .</p>
		<p>Make sure not to insert the cam screw: Too deep as shown in figure B as this will cause the cam screw to be misaligned and unable to interlock properly.</p>
		<p>Also avoid inserting the cam screw too close to the surface of the hole as shown in figure C, as this will cause the cam lock to be too loose, and not interlock properly.</p>

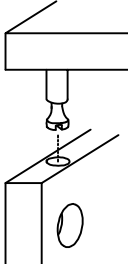
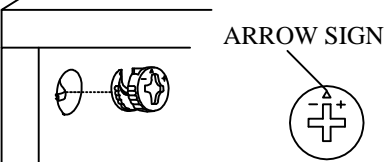
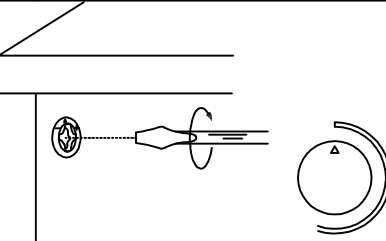
	<p>2. Connect the panels together.</p>
	<p>3. When inserting the cam lock make sure the arrow of the cam lock faces the cam screw.</p>
	<p>4. To tighten the cam lock turn the cam lock clockwise 90-180 degree or until the arrow is facing opposite the place cam lock was inserted.</p> <p>NOTE: DO NOT USE AN AUTOMATIC SCREWDRIVER TO TIGHTEN CAM LOCKS.</p>



Note:

- Read these instructions carefully before assembling.
- Tools required : Phillips screwdriver, flat screwdriver.
- Find a clean, smooth area on which to work , such as a carpet, in order to avoid scratching the wood surfaces.
- Wait to dispose of the packing material until assembly is complete and all parts and hardware are accounted for.
- Two or more people might be required for assembly.
- Max weight capacity 200 lbs.

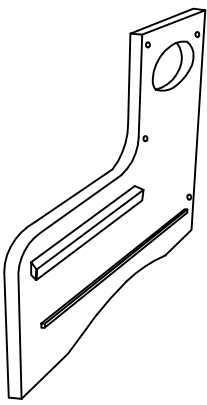
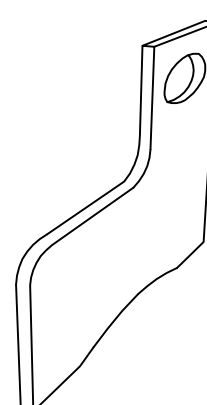
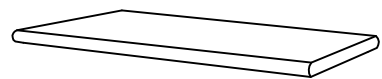
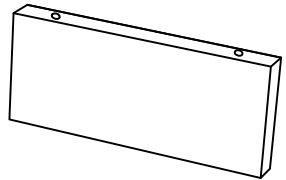
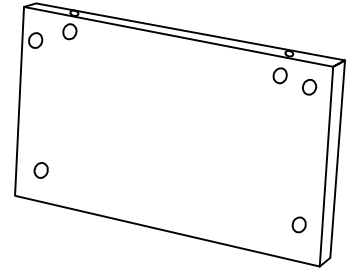
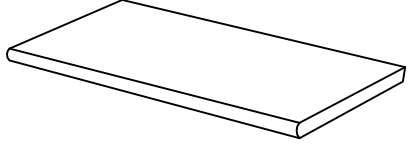
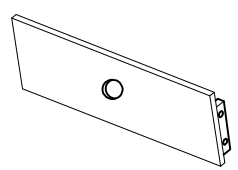
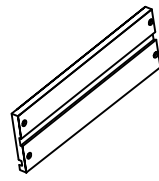
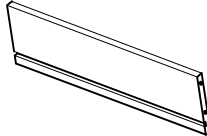
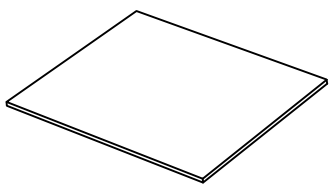
Part List

<p>A1 Quantity of 1</p>  <p>Left Side Panel</p>	<p>A2 Quantity of 3</p>  <p>Right Side Panel</p>	<p>A3 Quantity of 1</p>  <p>Top Panel</p>
<p>A4 Quantity of 1</p>  <p>Divider Panel</p>	<p>A5 Quantity of 1</p>  <p>Back Panel</p>	<p>A6 Quantity of 1</p>  <p>Second Top Panel</p>
<p>A7 Quantity of 1</p>  <p>Drawer Front Panel</p>	<p>A8 Quantity of 2</p>  <p>Drawer Side Panel</p>	<p>A9 Quantity of 1</p>  <p>Drawer Back Panel</p>
<p>A10 Quantity of 1</p>  <p>Drawer Bottom Panel</p>		

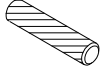
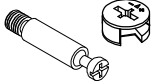
Hardware List

<p>B1</p>  <p>Wood Dowel</p>	<p>Quantity of 4</p>	<p>B2</p>  <p>Cam-lock</p>	<p>Quantity of 12</p>	<p>B3</p>  <p>Screw</p>	<p>Quantity of 4</p>	<p>B4</p>  <p>Screw</p>	<p>Quantity of 8</p>
---	----------------------	---	-----------------------	---	----------------------	--	----------------------

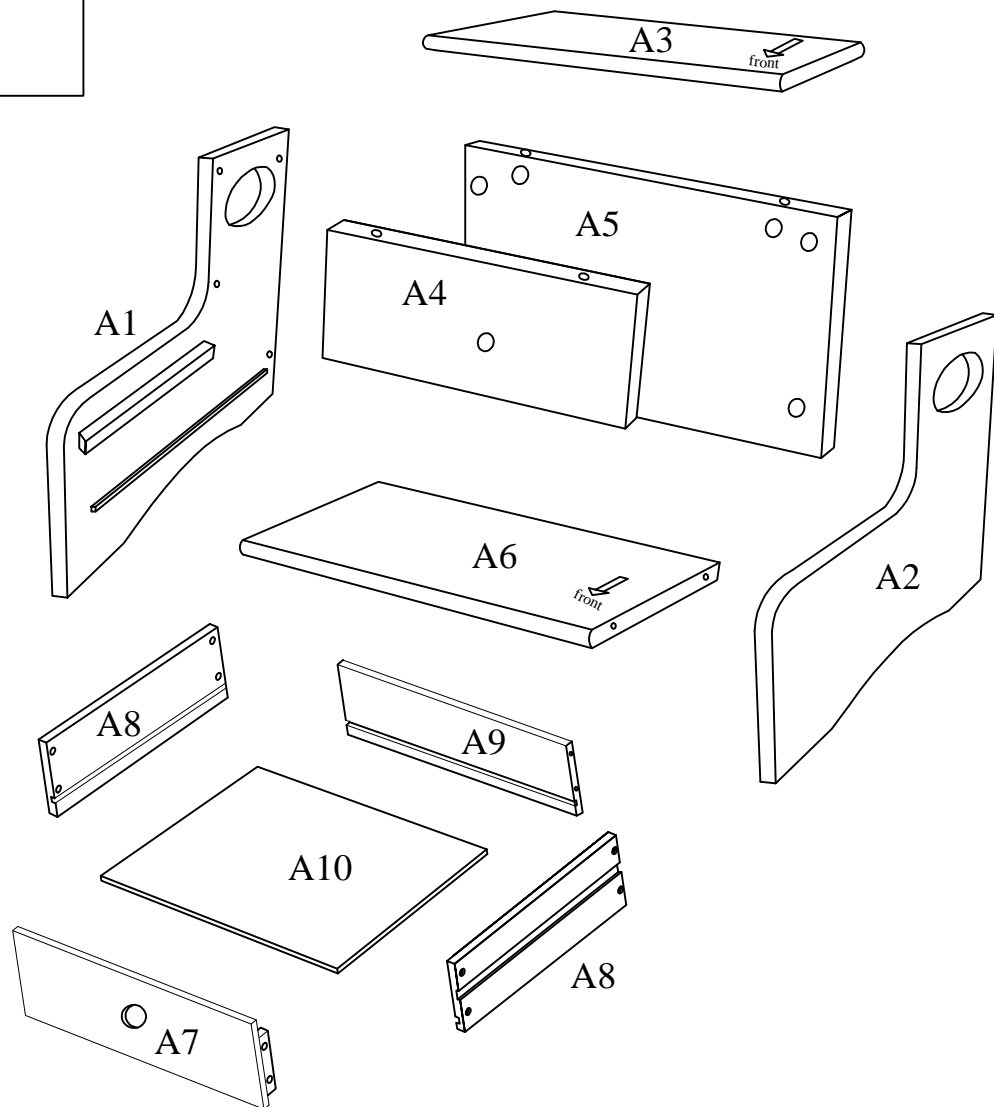
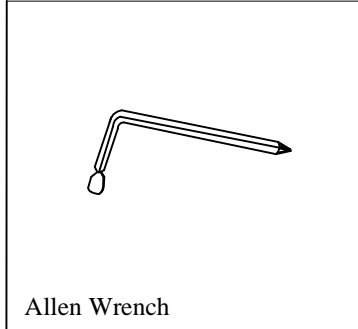

Assembly instructions

Step 1:

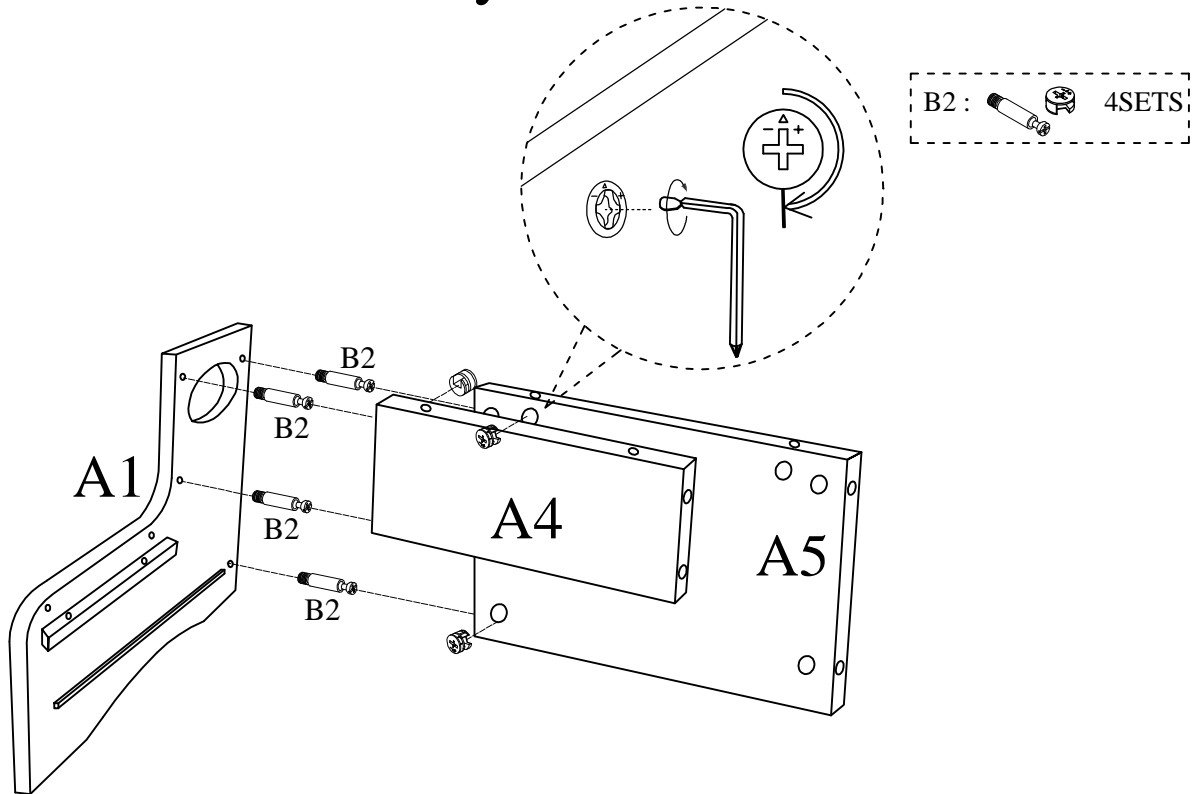

Assemble Left Side Panel A1 to Back Panel A5 & Divider Panel A4 using Cam-locks B2 as shown above.

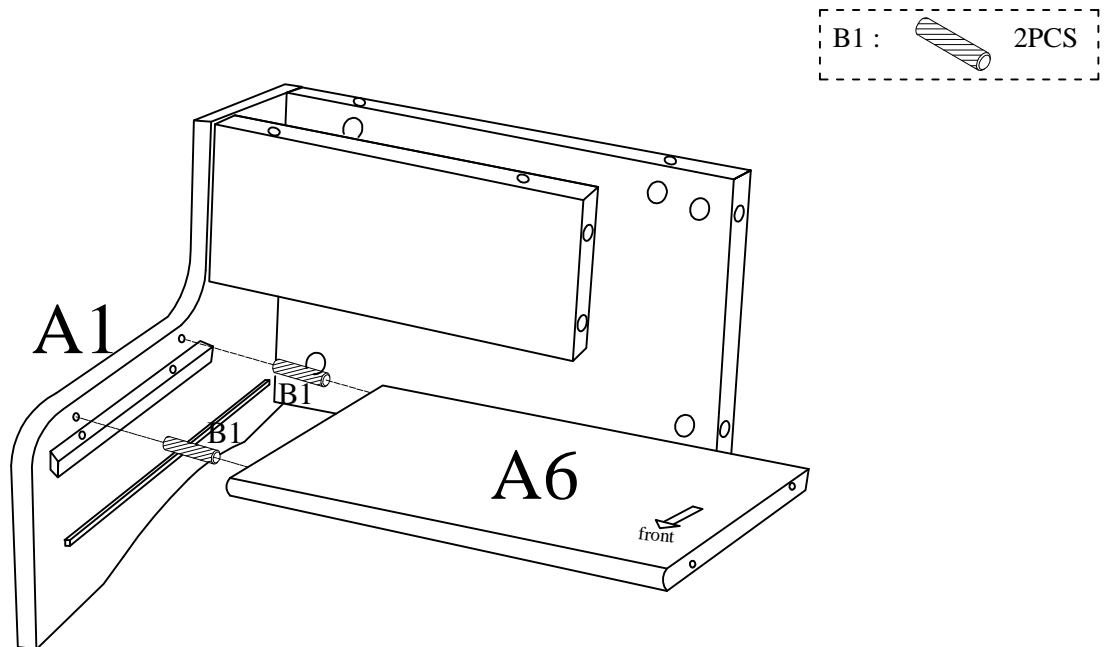

Step 2:

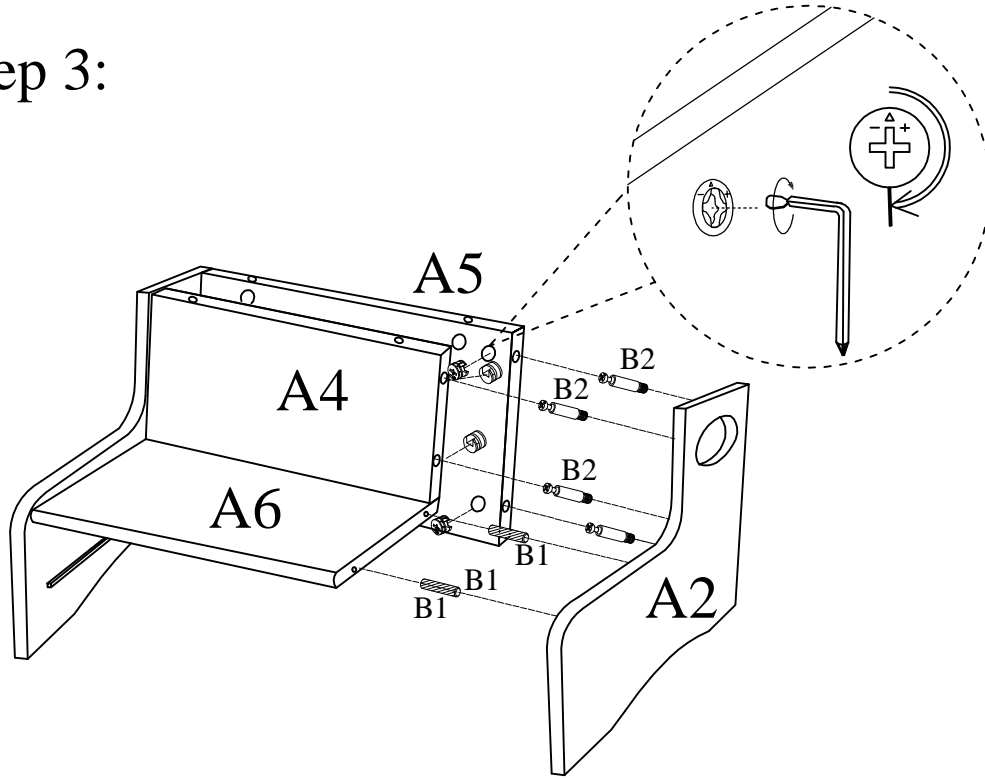

Assemble Second Top Panel A6 to Left Side Panel A1 using Wood Dowel B1 as shown above.

Step 3:





B1 :		2PCS
B2 :		4SETS

Assemble Right Side Panel A2 to Back Panel A5 & Divider Panel A4 & Second Top Panel A6 using Cam-locks B2 & Wood Dowels B1 as shown above.

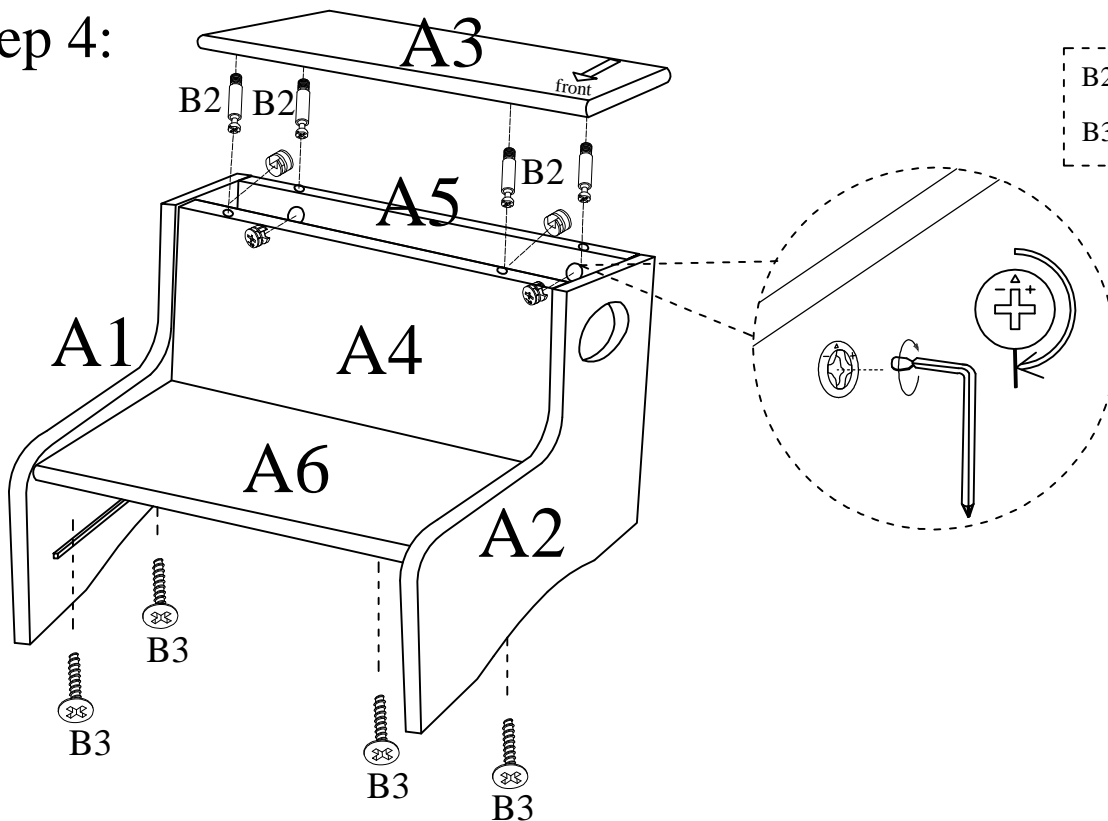
Step 4:



B2 :		4SETS
B3 :		4PCS

- 1). Assemble Top Panel A3 to Back Panel A5 & Divider Panel A4 using Cam-locks B2 as shown above.
- 2). Tighten Second Panel A6 to Side Panels A1 & A2 using Screws B3 as shown above.

Step 5:

B4:  8PCS

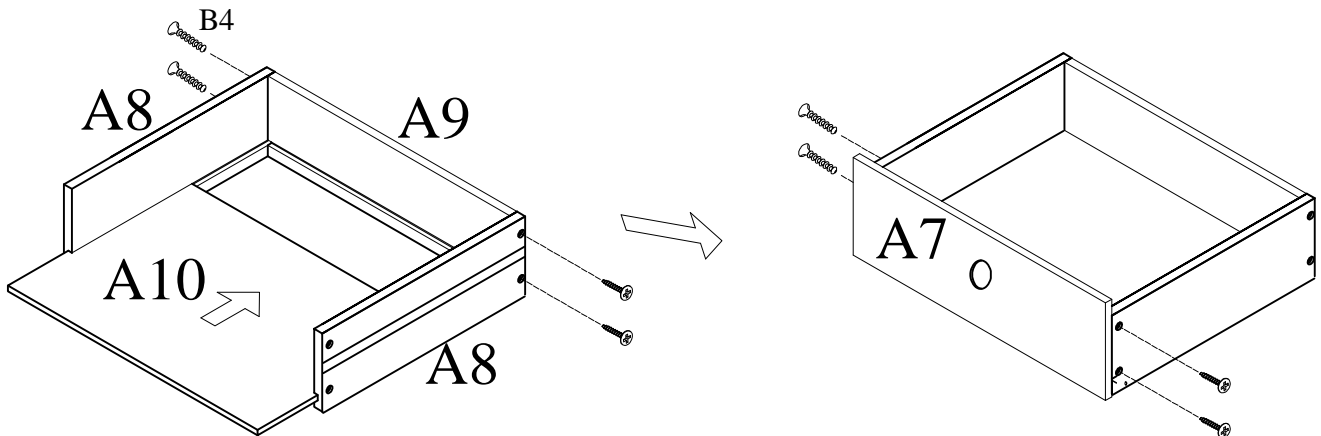

- 1). Assemble Drawer Side Panels A8 to Drawer Back Panel A9 using Screws B4.
- 2). Insert Drawer Bottom Panel A10 into the grooves on the Drawer Side Panels A8, Drawer Back Panel A9.
- 3). Assemble Drawer Front Panel A7 to Drawer Side Panels A8 using Screws B4.

Step 6:

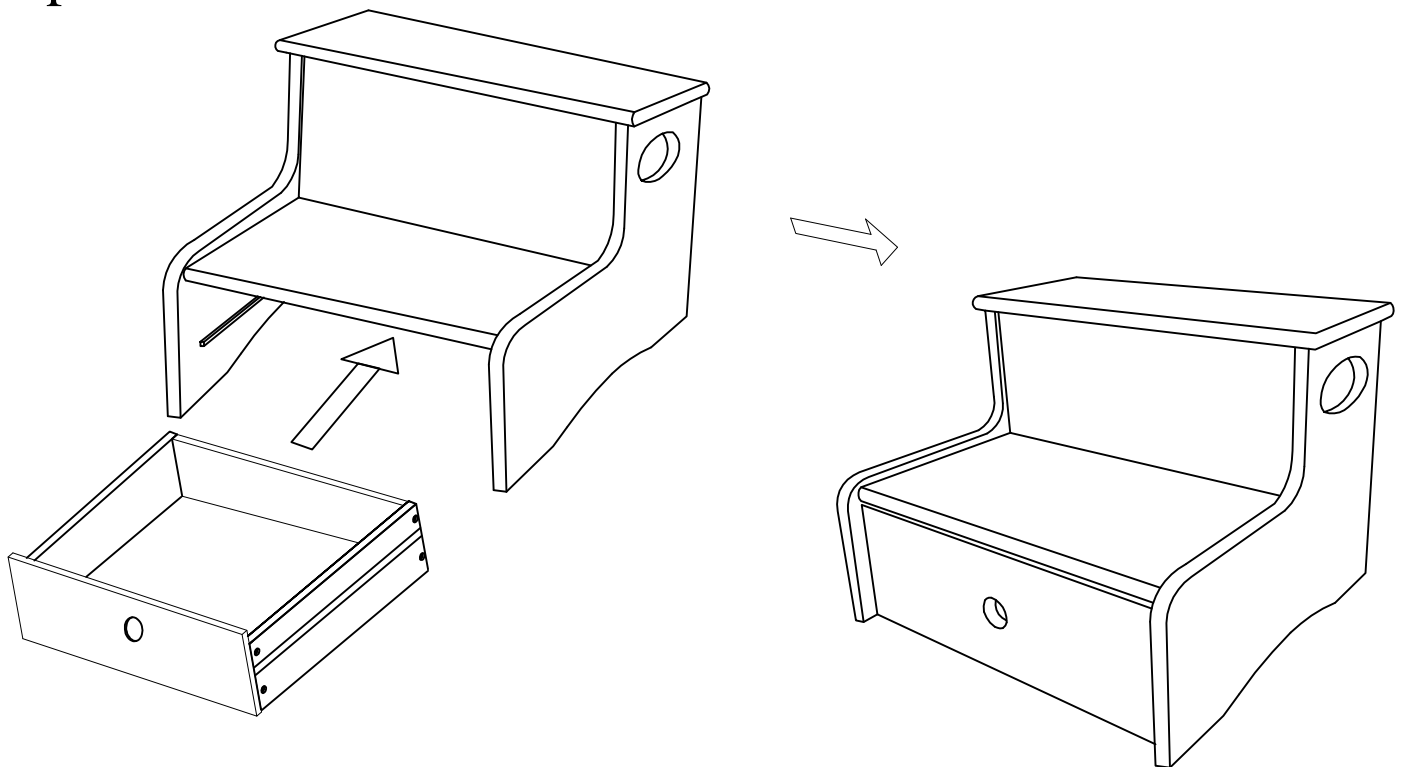

Insert the drawer into the unit.