

ASSEMBLY INSTRUCTIONS

Style # T1179-E End table

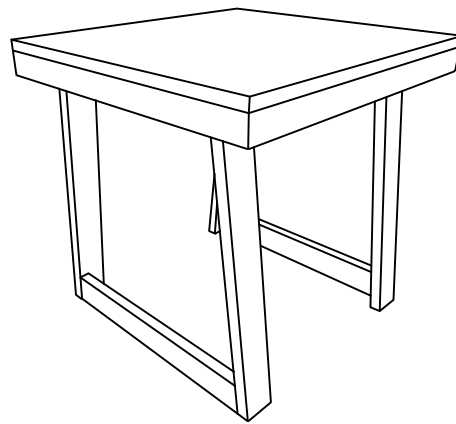

NOTE TO CUSTOMERS:

- For ease and speed of assembly we recommend that before you commence each step of the assembly that you identify all the parts required to complete that step.
- We recommend that where possible you allow sufficient space to assemble the item as close as possible to the place where it will be once assembled.
- For the protection of your furniture we recommend that the product is placed on protected surfaces during assembly to prevent any damage.
- During assembly do not over tighten ,as this may damage the product.
- Please ensure you retain all the product packaging until the item completely assembled.
- Please periodically check all fittings and re-tighten as necessary.
- Never allow any liquids to remain on your furniture as absorption can cause the wood to warp or the finish to de-laminate.
- It is recommended that this item should be assembled by two adults.

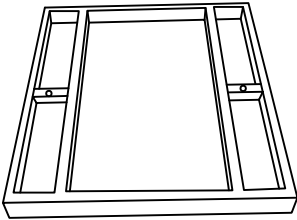
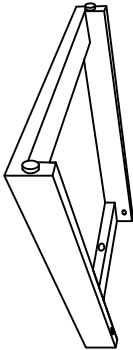

Part List

<p>A1</p> <p style="text-align: right;">Quantity of 1</p> <div style="text-align: center; margin: 20px 0;">  </div> <p>Top Panel</p>	<p>A2</p> <p style="text-align: right;">Quantity of 2</p> <div style="text-align: center; margin: 20px 0;">  </div> <p>Leg</p>
---	---

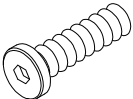
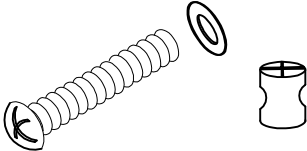
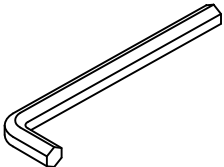
Hardware List

<p>B1</p> <p style="text-align: right;">Quantity of 2</p> <div style="text-align: center; margin: 20px 0;">  </div> <p>Screw</p>	<p>B2</p> <p style="text-align: right;">Quantity of 4</p> <div style="text-align: center; margin: 20px 0;">  </div> <p>Bolt with washer & nut</p>
<div style="text-align: center; margin: 20px 0;">  </div> <p style="text-align: right;">Quantity of 1</p>	

Assembly instructions

B1 :		4pcs
B2 :		8sets
B3 :		1pcs

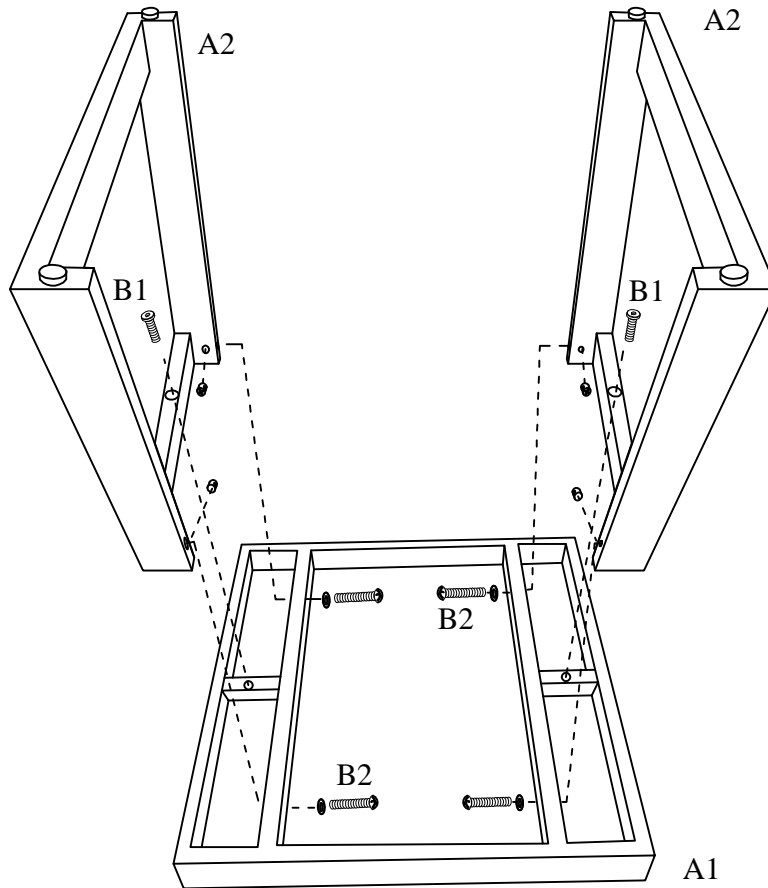

Do not fully tighten Bolts until all of them are attached.

