

ASSEMBLY INSTRUCTIONS

Style # H0316 / H0318 Foldable Wall Desk

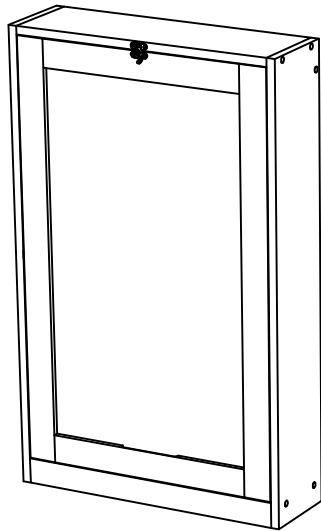

CLOSE

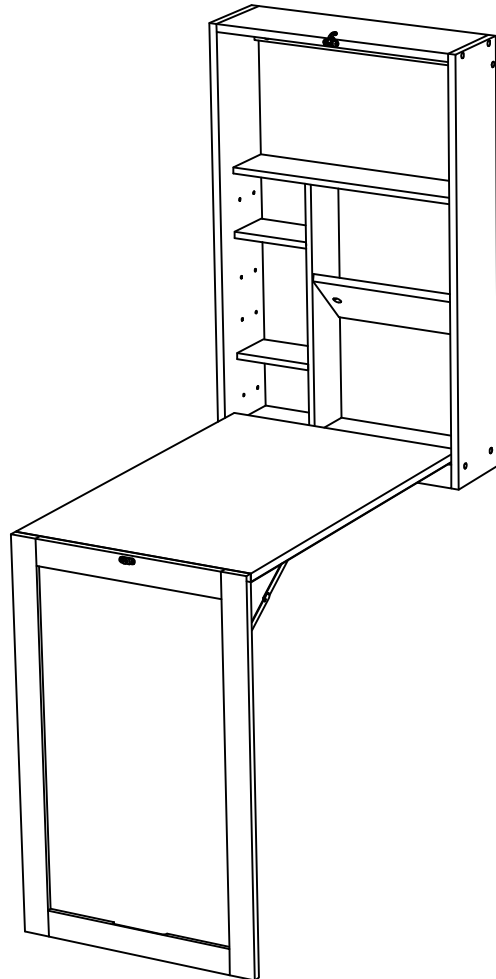

OPEN

NOTE TO CUSTOMERS:

- For ease and speed of assemble we recommend that before you commence each step of the assembly that you identify all the parts required to complete that step.
- We recommend that where possible you allow sufficient space to assemble the item as close as possible to the place where it will be once assembled.
- For the protection of your furniture we recommend that the product is placed on protected surfaces during assembly to prevent any damage.
- During assembly do not over tighten, as this may damage the product.
- Please ensure you retain all the product packaging until the item completely assembled.
- Please periodically check all fittings and re-tighten as necessary.
- Never allow any liquids to remain on your furniture as absorption can cause the wood to warp or the finish to de-laminate.
- It is recommended that this item should be assembled by two adults.

To insert a cam lock: (Please read below instructions before assembling)

Diagram A

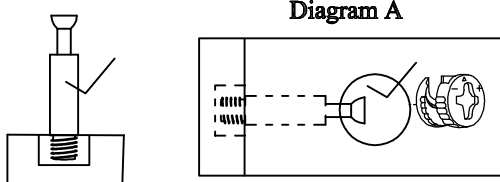

1. Insert cam screw into hole as shown in diagram A .

Diagram B

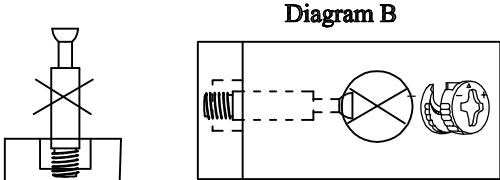

Make sure not to insert the cam screw:
Too deep as shown in figure B as this will cause the cam screw to be misaligned and unable to interlock properly.

Diagram C

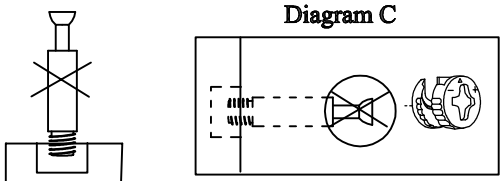

Also avoid inserting the cam screw too close to the surface of the hole as shown in figure C, as this will cause the cam lock to be too loose, and not interlock properly.

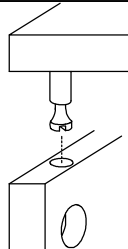

2. Connect the panels together.

Diagram 3

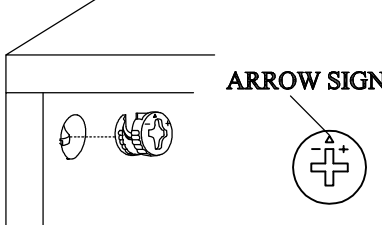

3. When inserting the cam lock make sure the arrow of the cam lock faces the cam screw.

Diagram 4

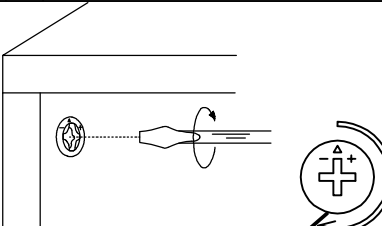







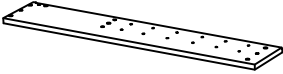

4. To tighten the cam lock turn the cam lock clockwise 90-180 degree or until the arrow is facing opposite the place cam lock was inserted.

NOTE: DO NOT USE AN AUTOMATIC SCREWDRIVER TO TIGHTEN CAM LOCKS.

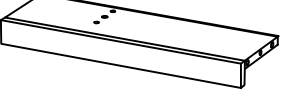



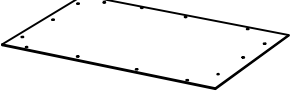

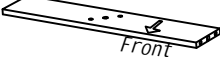
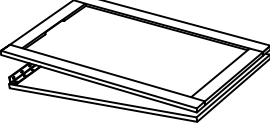

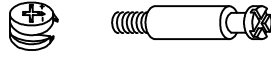

Note:

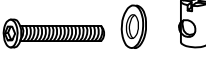
- Read these instructions carefully before assembling.
- Tools required : Phillips screwdriver, flat screwdriver.
- Find a clean, smooth area on which to work , such as a carpet, in order to avoid scratching the wood surfaces.
- Wait to dispose of the packing material until assembly is complete and all parts and hardware are accounted for.
- Two or more people might be required for assembly.

Part List

<p>A1. Quantity of 1</p>  <p>Left Side Panel</p>	<p>A2. Quantity of 1</p>  <p>Right Side Panel</p>	<p>A3. Quantity of 1</p>  <p>Middle Shelf</p>	<p>A4. Quantity of 1</p>  <p>Bottom Panel</p>
<p>A5. Quantity of 2</p>  <p>Left Shelf</p>	<p>A6. Quantity of 1</p>  <p>Right Shelf</p>	<p>A7. Quantity of 1</p>  <p>Top Panel</p>	<p>A8. Quantity of 1</p>  <p>Back Panel</p>
<p>A9. Quantity of 1</p>  <p>Connect Bar</p>	<p>A10. Quantity of 1</p>  <p>Di v i d e r</p>	<p>A11. Quantity of 1</p>  <p>Fol d i n g D e s k T o p</p>	

Hardware List

<p>B1. Quantity of 6</p>  <p>Cam lock</p>	<p>B2. Quantity of 18</p>  <p>Wood Dowel</p>	<p>B3. Quantity of 10</p>  <p>Bol t w i t h n u t & w a s h e r</p>	<p>B4. Quantity of 14</p>  <p>Screw</p>
<p>B5. Quantity of 13</p>  <p>Screw</p>	<p>B6. Quantity of 1</p>  <p>Locker</p>	<p>B7. Quantity of 8</p>  <p>Supporter</p>	<p>B8. Quantity of 12</p>  <p>Cap</p>
<p>B9. Quantity of 1</p> 	<p>B10. Quantity of 2</p>  <p>Anchor with Screw</p>		

Step 1:

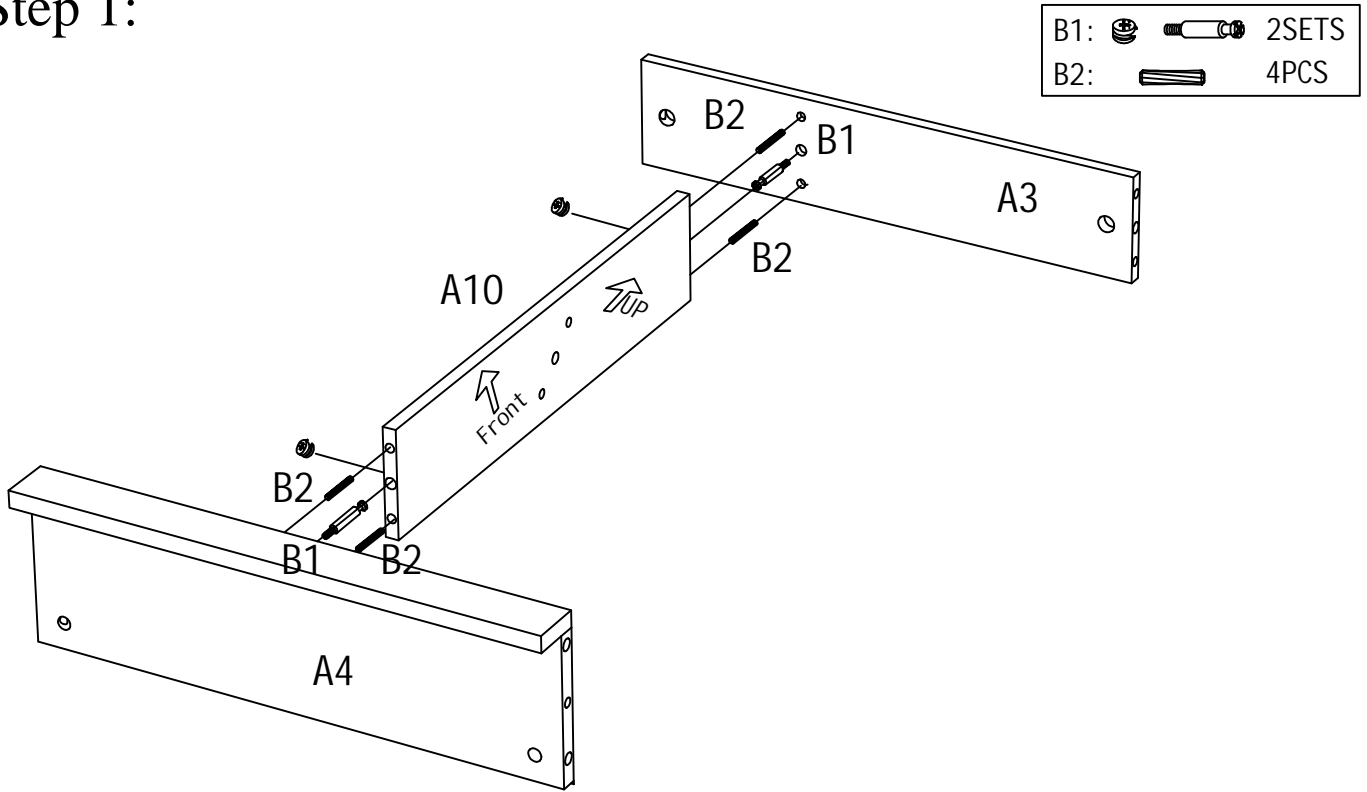

Assemble Divider (A10) to Middle Shelf (A3) and Bottom Panel (A4) using Camlocks (B1) and Wood Dowels (B2).

Step 2:

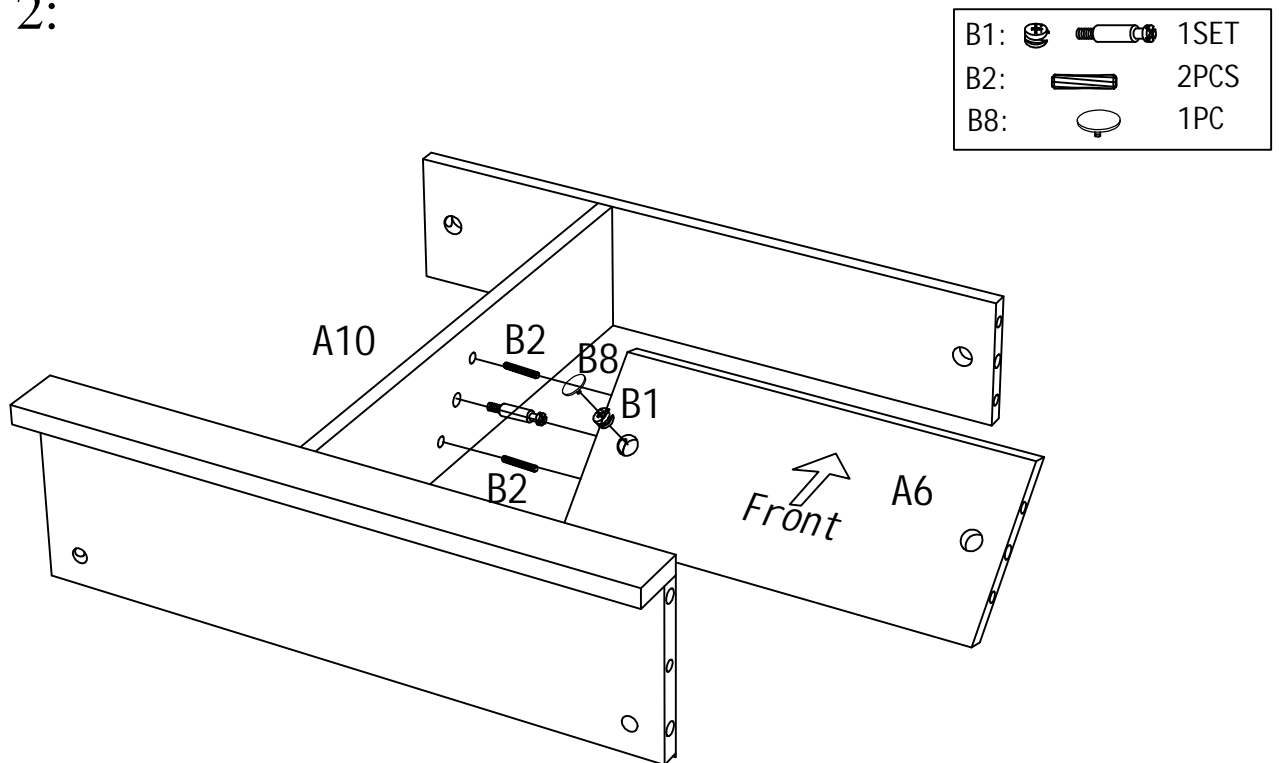

Assemble Right Shelf (A6) to Divider (A10) using Camlocks (B1) and Wood Dowels (B2). Then insert Cap (B8) to cover B1 as shown above.

Step 3:

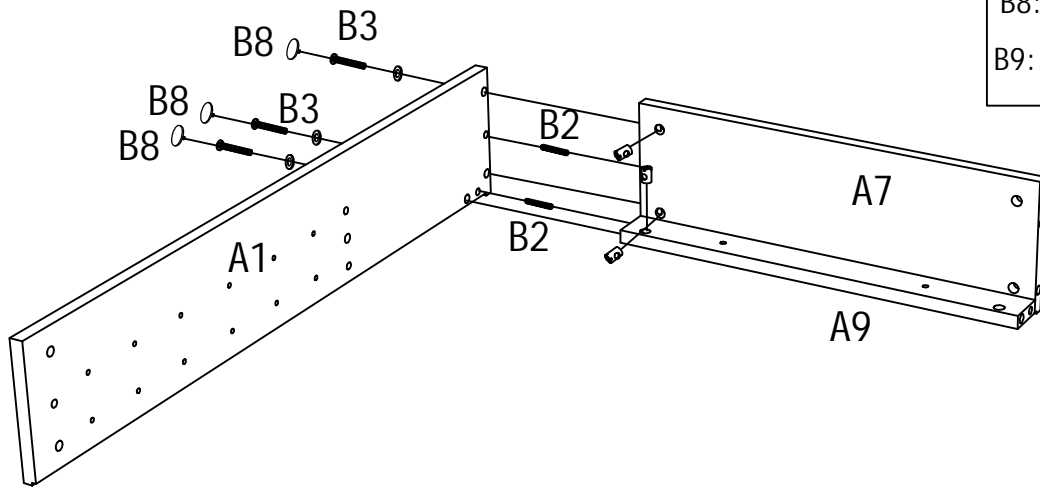

B2:		2PCS
B3:		3SETS
B8:		3PCS
B9:		1PC

Assemble Top Panel (A7) and Connect Bar (A9) to Left Side Panel (A1) using Bolt with nuts & washers (B3) and Wood Dowels (B2). Then cover the holes by Caps (B8) as shown above.

Step 4:

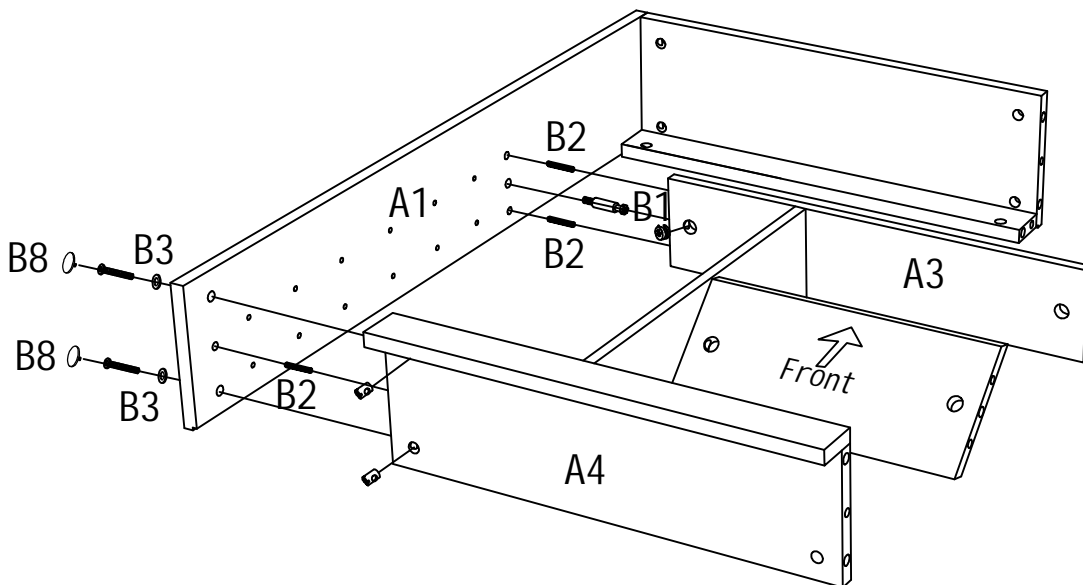

B1:		1SET
B2:		3PCS
B3:		2SETS

B8:		2PCS
B9:		1PC

Assemble Middle Shelf (A3) and Bottom Panel (A4) to the Left Side Panel (A1) using Bolt with nuts & washers (B3) and Wood Dowels (B2) & Camlocks (B1). Then cover the holes by Caps (B8) as shown above.

Step 5:

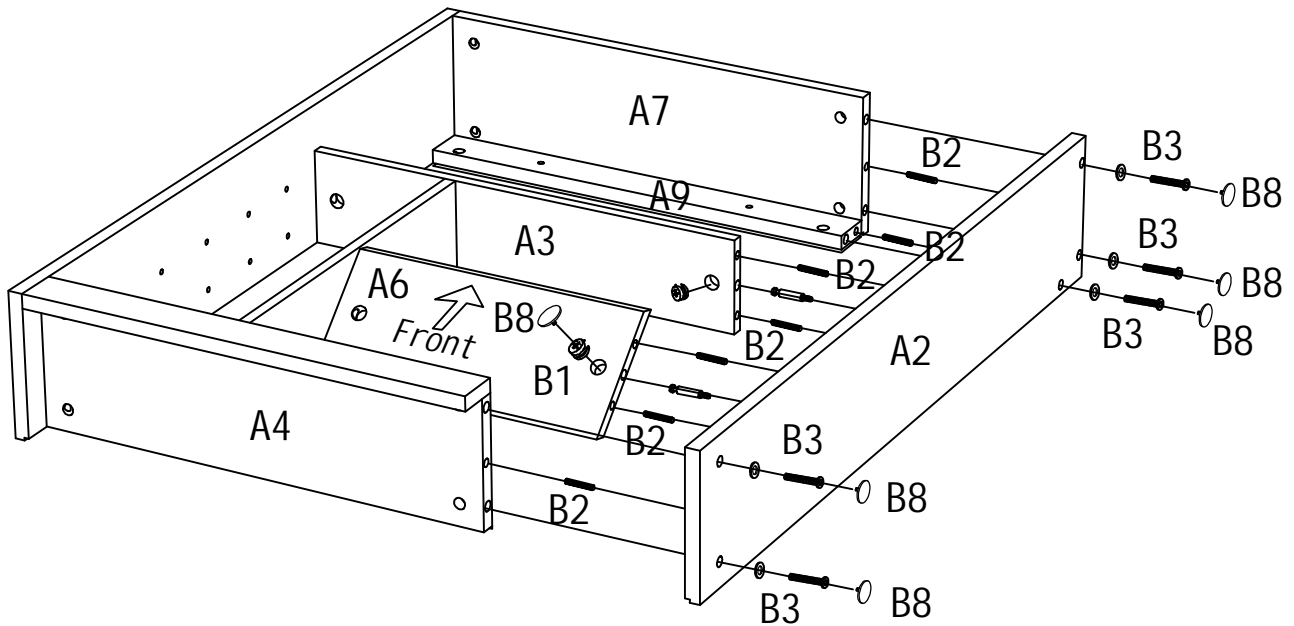
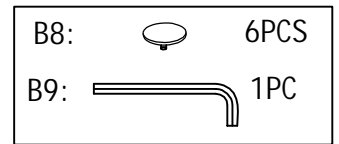
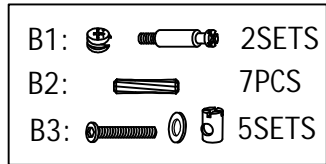

Assemble Middle Shelf (A3), Bottom Panel (A4) & Top Panel (A7) to the Right Side Panel (A2) using Bolt with nuts & washers (B3) and Wood Dowels (B2) & Camlocks (B1). Then cover the holes by Caps (B8) as shown above.

Step 6:

B4:		14PCS
-----	---	-------

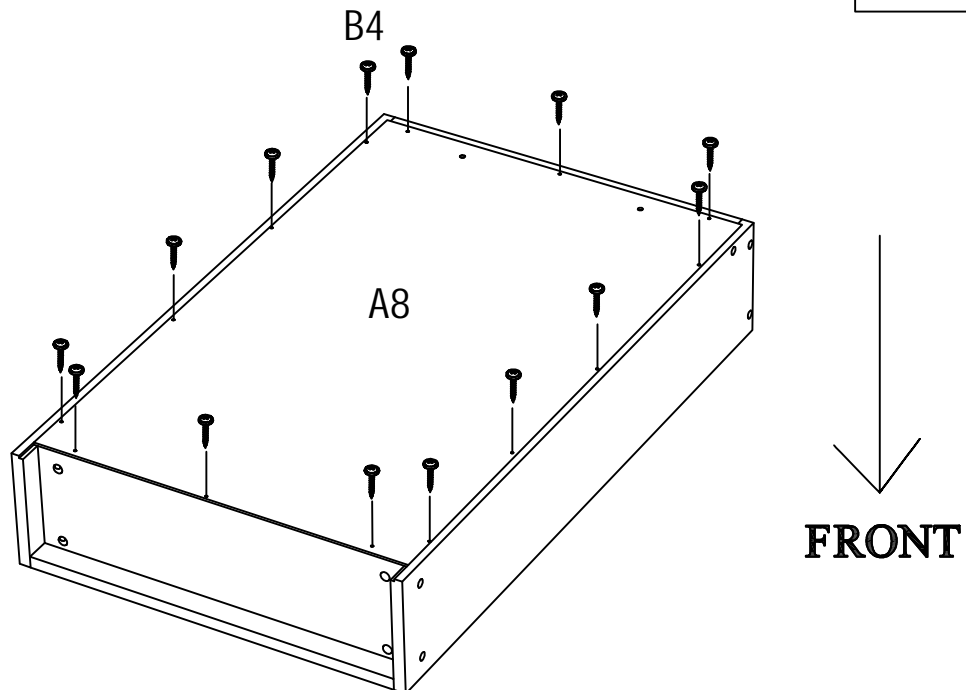

Attach Back Panel (A8) to the back of this unit using Screws (B4).

Step 7:

B5:  9PCS

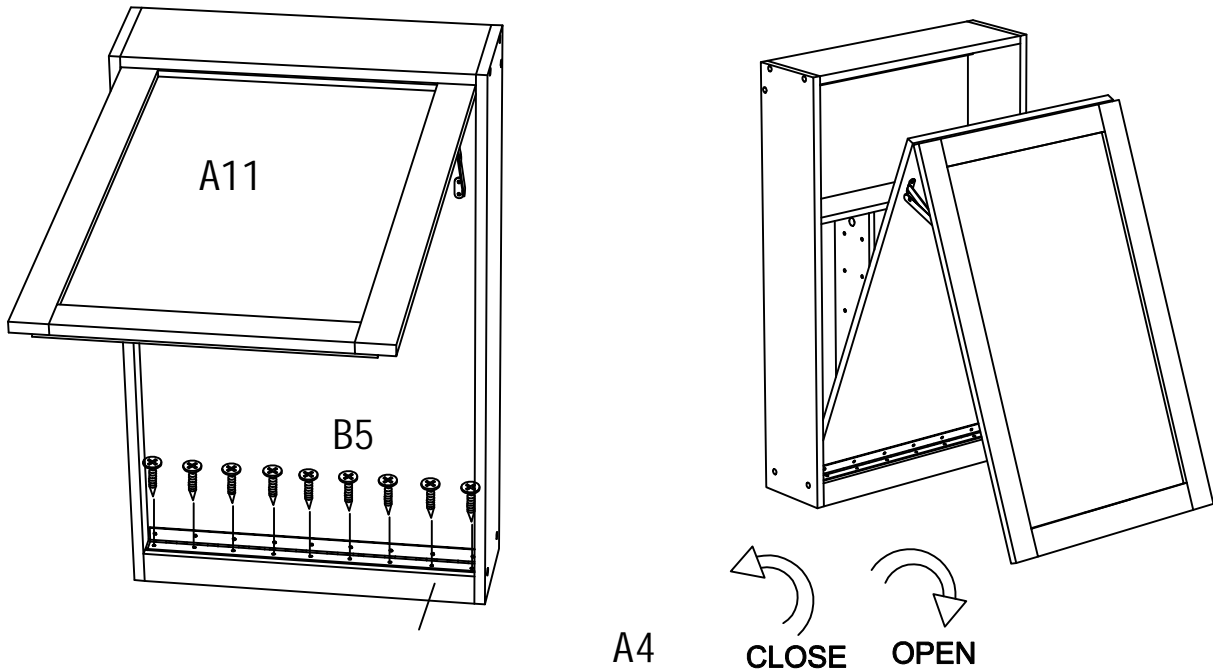

Assemble Folding Desk Top (A11) via attached hinge on the bottom of desk top with Screws (B5) to Bottom Panel (A4) as shown above.

Step 8:

B10:  2PCS

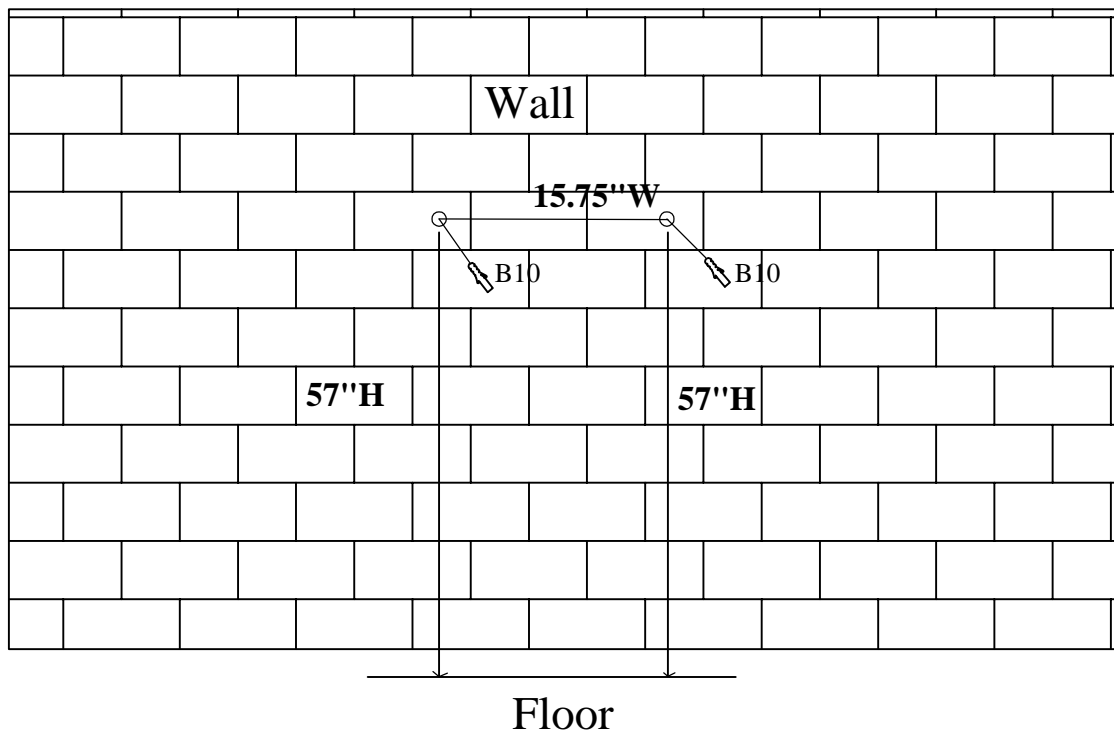

For your safety please insert Anchors (B10) into the wall as above drawing shown.

Step 9:

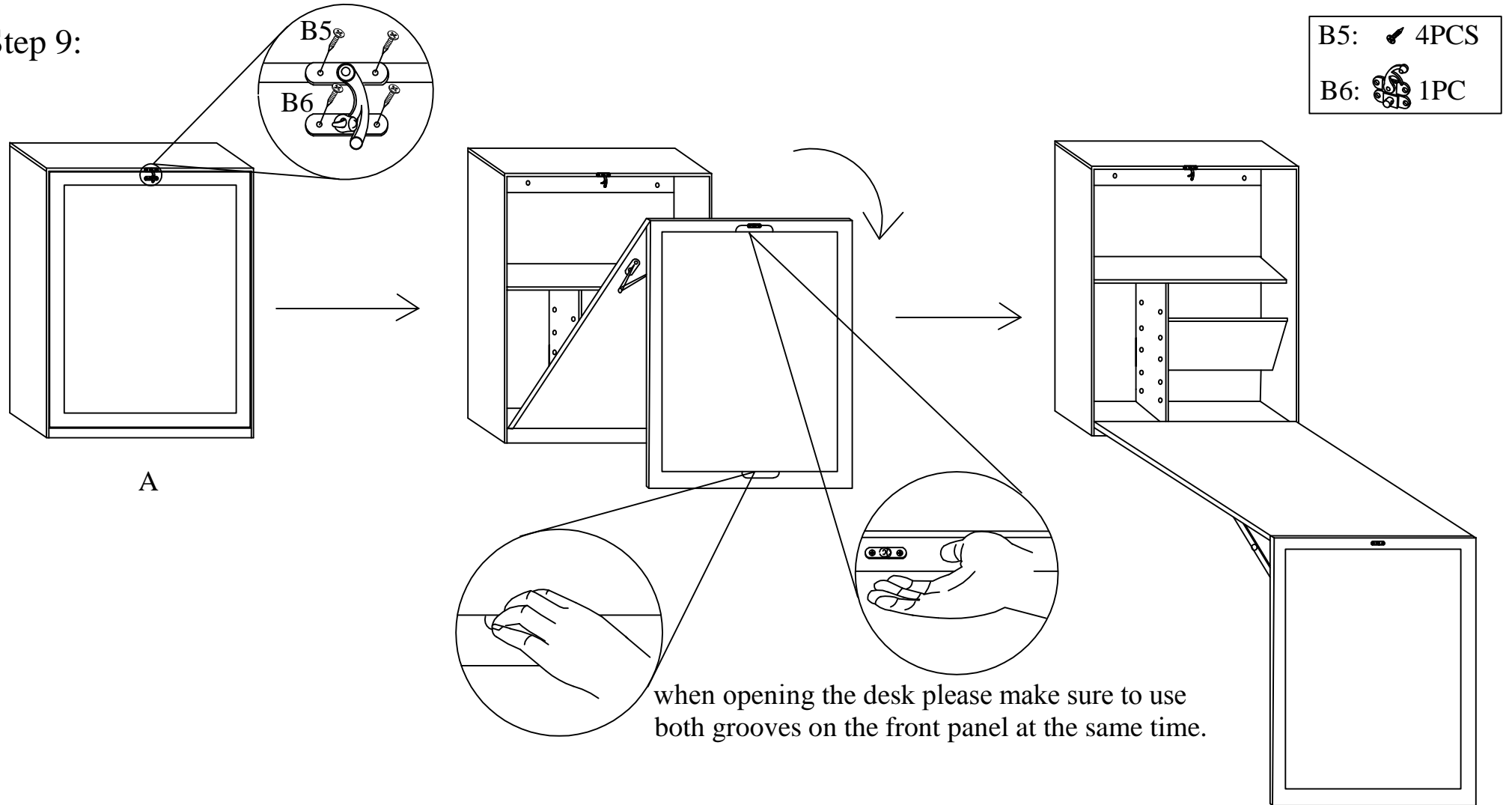

1. Attach Safety Lock (B6) to Desk using included Screws (B5).
2. Open Desk carefully as above drawing shown, open the desk by using both grooves on the front panel at the same time.

Step 10:

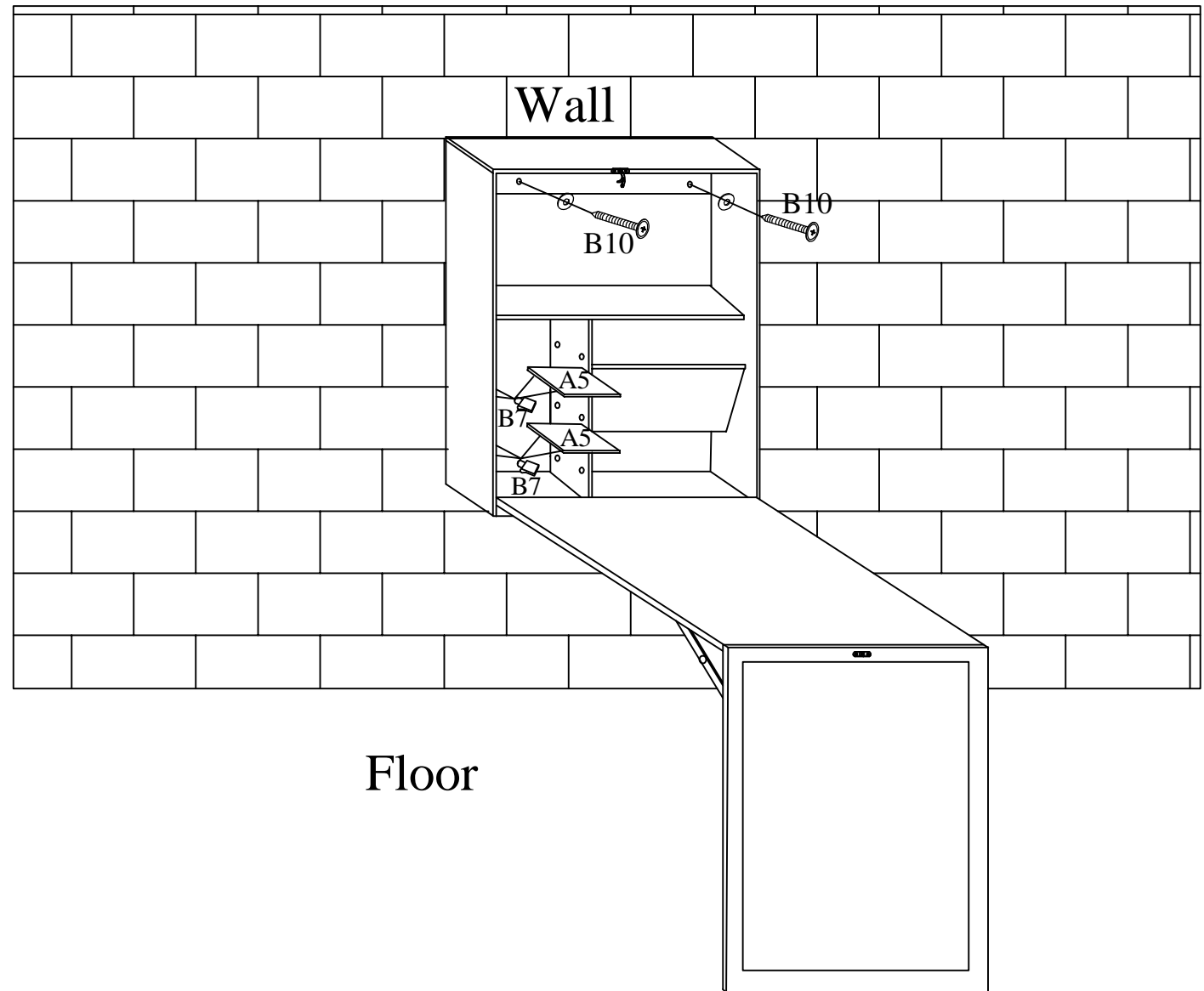
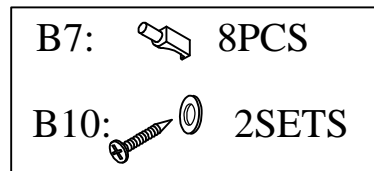

1. Assemble Desk to the wall using Screws and Flat Washers (B 10) as above drawing shown.
2. Insert Shelf Supports (B7) into the holes on Desk , then put Shelves (A5) on top of Shelf Supports (B7).

Step 11:

Warning:

1. Max load capacity 100lbs.
2. Only use chalk to write on the blackboard.
3. Only use whiteboard marker to write on the whiteboard.

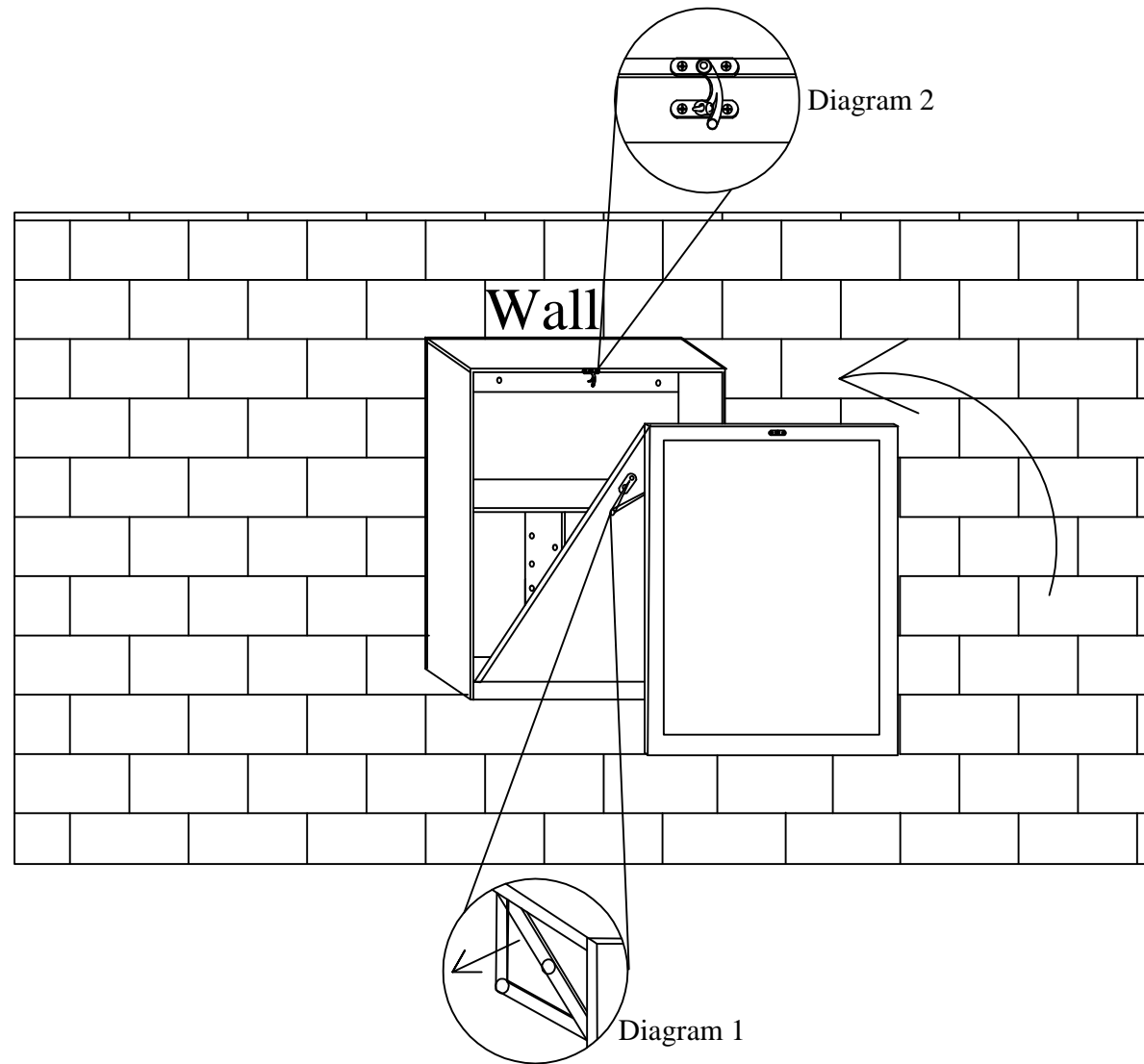

When closing the desk, unlock the safety hinge by pushing it in slightly(see diagram 1) , then fold the desk back and lock with top safety lock(see diagram 2)
NOTE: Please be cautious when closing the safety hinge, in order not to get your fingers trapped in the hinge.

APPENDIX: Dimension of Hardwares in this AI.

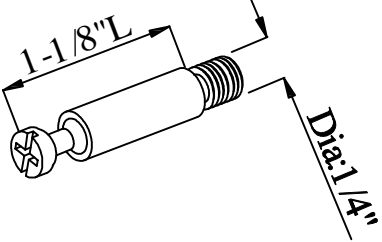
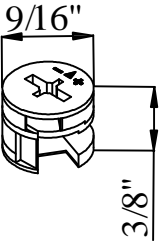
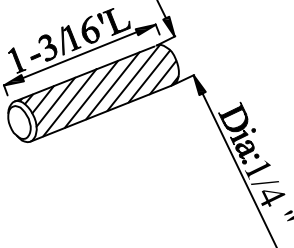
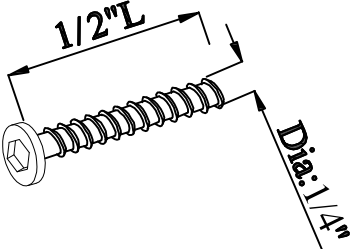
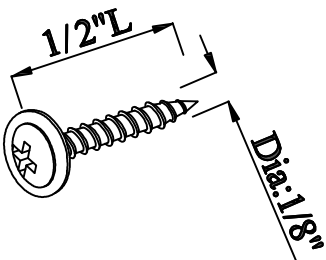
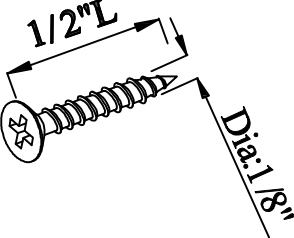
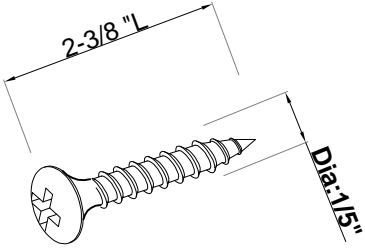
<p>B1.</p>  <p>Cam-bolt</p>	<p>B1.</p>  <p>Cam-nut</p>	<p>B2.</p>  <p>wood dowel</p>
<p>B3.</p>  <p>Screw</p>	<p>B4.</p>  <p>Screw</p>	<p>B5.</p>  <p>Screw</p>
<p>B10.</p>  <p>Screw</p>		