

ASSEMBLY INSTRUCTIONS

MODEL: B6570-Q-HB, B6570-Q-FB, B6570-KQ-RAIL

Thank you for purchasing this quality product. Be sure to check all packing material carefully for small parts which may have come loose inside the carton during shipment. Identify and count all parts and compare with hardware list as below:

PART LIST			
(BOX 1) BOX OF HEADBOARD			
ITEM	DRAWING	DESCRIPTION	QTY
A		HEAD BOARD	1

(BOX 2) BOX OF FOOTBOARD			
ITEM	DRAWING	DESCRIPTION	QTY
B		FOOT BOARD	1
C		WOODEN SLAT	4
D		SLATS SUPPORT	4

(BOX 2) BOX OF FOOTBOARD HARDWARE LIST				
ITEM	DRAWING	DESCRIPTION	DIMENSION	QTY
E		C.S.K SCREW (M4)	4 x 32mm	8

(BOX 3) BOX OF SIDE RAILS			
ITEM	DRAWING	DESCRIPTION	QTY
F		SIDE RAILS	2

Screw Driver is not included

STEP 1

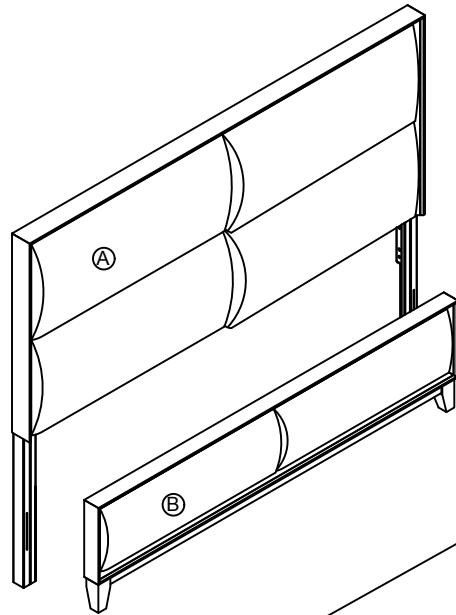

STEP 2

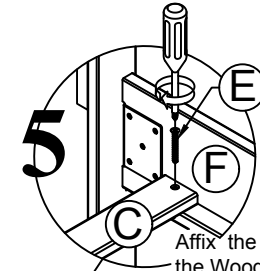
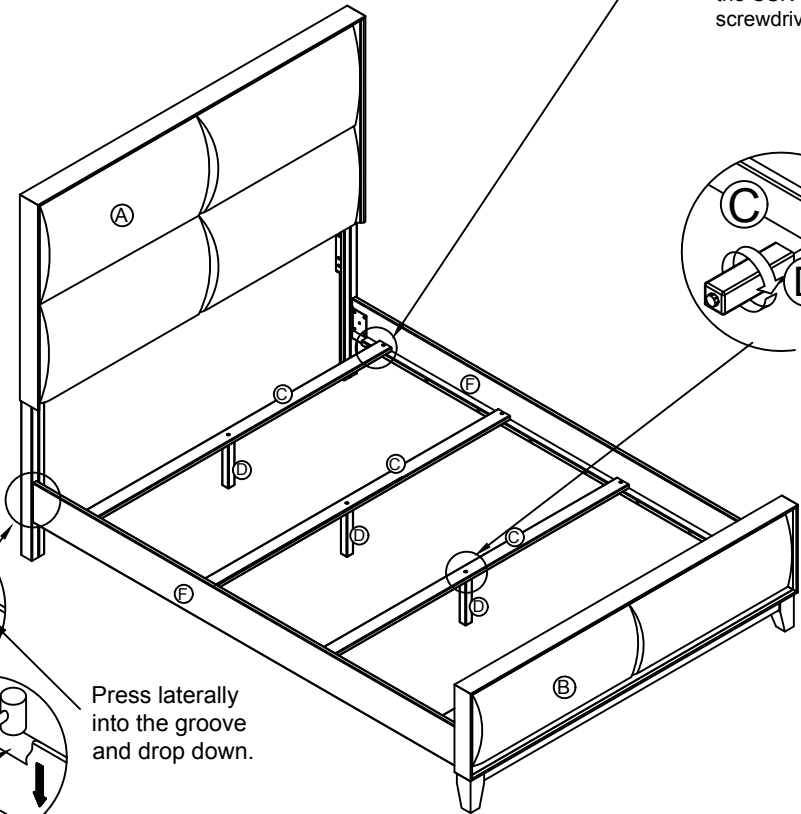

Affix the Side Rail (F) to the Wooden Slat (C) using the CSK screw (E) and a screwdriver.

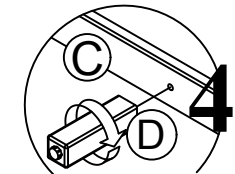

Affix the Bottom Rail Support (D) to Wooden Slat (C) as Shown.

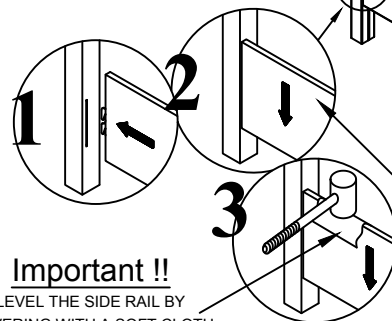

Press laterally into the groove and drop down.

Important !!

LEVEL THE SIDE RAIL BY COVERING WITH A SOFT CLOTH AND TAPPING WITH A HAMMER.

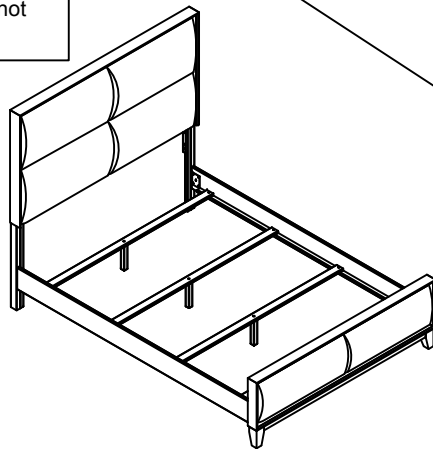

COMPLETED ASSEMBLY

NOTE: MUST TIGHTEN SCREW PERIODICALLY. WITH USE SCREWS WILL BECOME LOOSE CHECK TIGHT OF ALL SCREWS EVERY 6-8 WEEKS. CLEANING INSTRUCTION

After assembled, clean & polish the complete parts if necessary with soft cloth and industrial recognized furniture polish.

MADE IN MALAYSIA

THE HARDWARE IS LOCATED IN THE PACKING ITEMS