

ASSEMBLY INSTRUCTION

Style # B5116

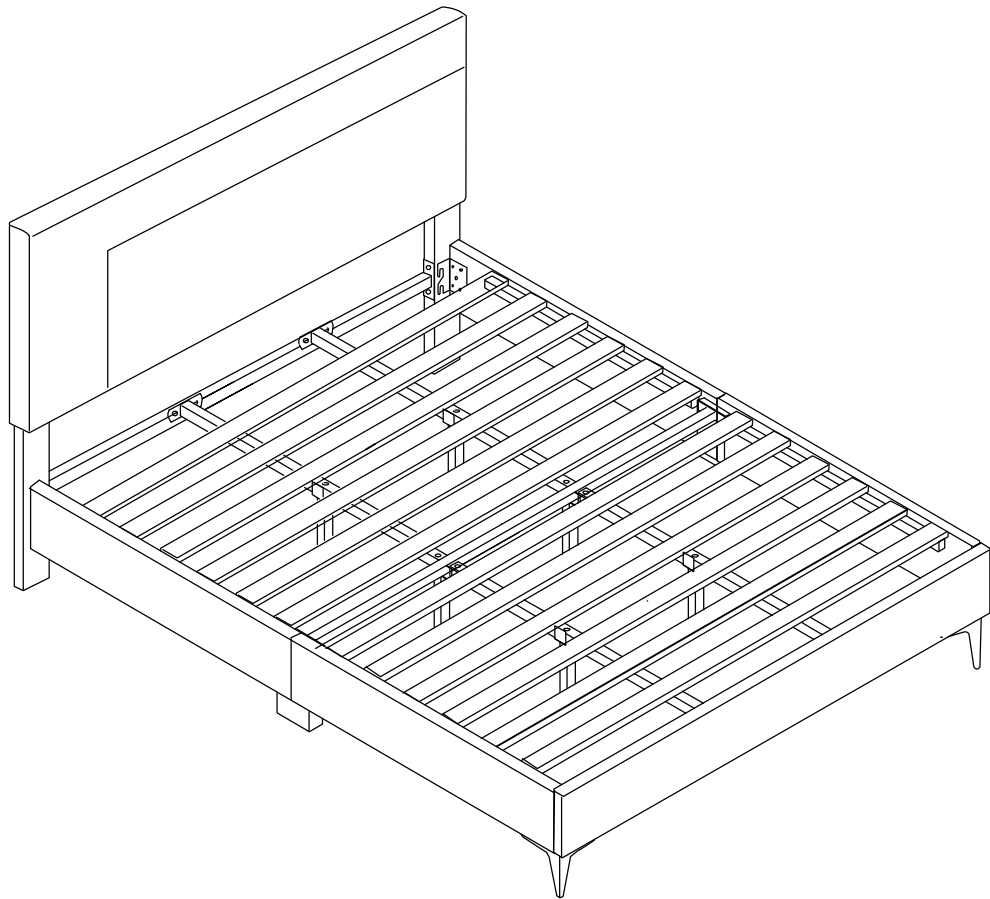

KING SIZE







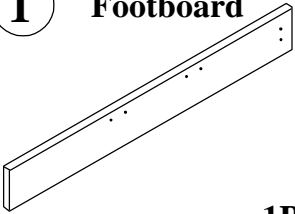
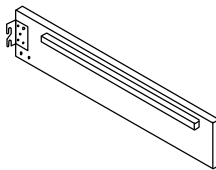
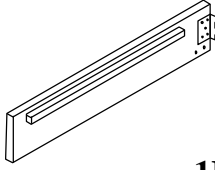
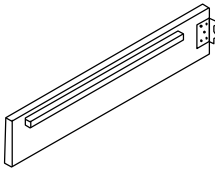
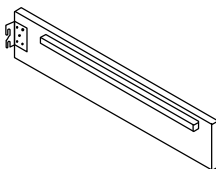
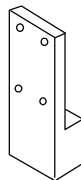
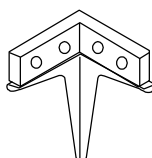
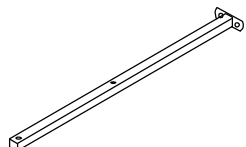

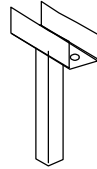
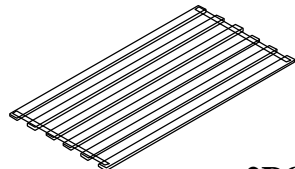
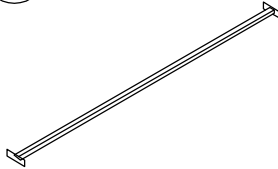
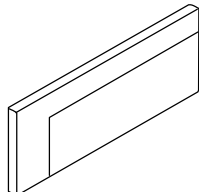
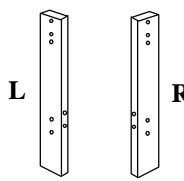
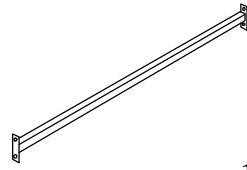
NOTE TO CUSTOMERS:

1. For ease and speed of assembly we recommend that before you commence each step of the assembly that you identify all the parts required to complete that step.
2. We recommend that where possible you allow sufficient space to assemble the item as close as possible to the place where it will be once assembled.
3. For the protection of your furniture we recommend that the product is placed on protected surfaces during assembly to prevent any damage.
4. During assembly do not over tighten, as this may damage the product.
5. Please ensure you retain all the product packaging until the item is completely assembled.
6. Please periodically check all fittings and re-tighten as necessary.
7. Never allow any liquids to remain on your furniture as absorption can cause the surface to warp or the finish to de-laminate.
8. It is recommended that this item should be assembled by two adults.

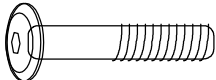
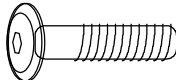
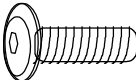
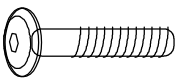
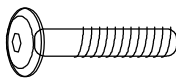
PART LIST

1 Footboard  1PC	2A Left Side Rail  1PC	2B Right Side Rail  1PC	3A Left Side Rail  1PC
3B Right Side Rail  1PC	4 Side Leg  2PCS	5 Metal Leg  2PCS	6 Center Rail  4PCS
7 Support Leg  4PCS	8 Support Leg  2PCS	9 Slats  2PCS	10 Center Bar  1PC
11 Headboard  1PC	12 Headboard Legs  1PC	13 Connect Bar  1PC	

HARDWARE LIST

A M8*60mm  Bolt 8PCS	B M8*45mm  Bolt 18PCS	C M8*20mm  Bolt 12PCS	D M6*38mm  Bolt 8PCS	E M6*30mm  Bolt 4PCS
F Washer  Washer 42PCS	G M8  Nut 4PCS	H M5  Allen Key 1PC	I M4  Allen Key 1PC	J  Spanner 1PC

WARNING:



1. Always use the recommended size of mattress or mattress support to help prevent the likelihood of entrapment or falls.
2. For your safety do not jump on the bed.
3. The use of water or sleep flotation mattress on the bed is not recommended.
4. The weight load on this bed should never exceed 500lbs. Exceeding this weight limit may cause the bed to collapse, resulting in serious personal injury and property damage.

STEP 1

Assembly instructions

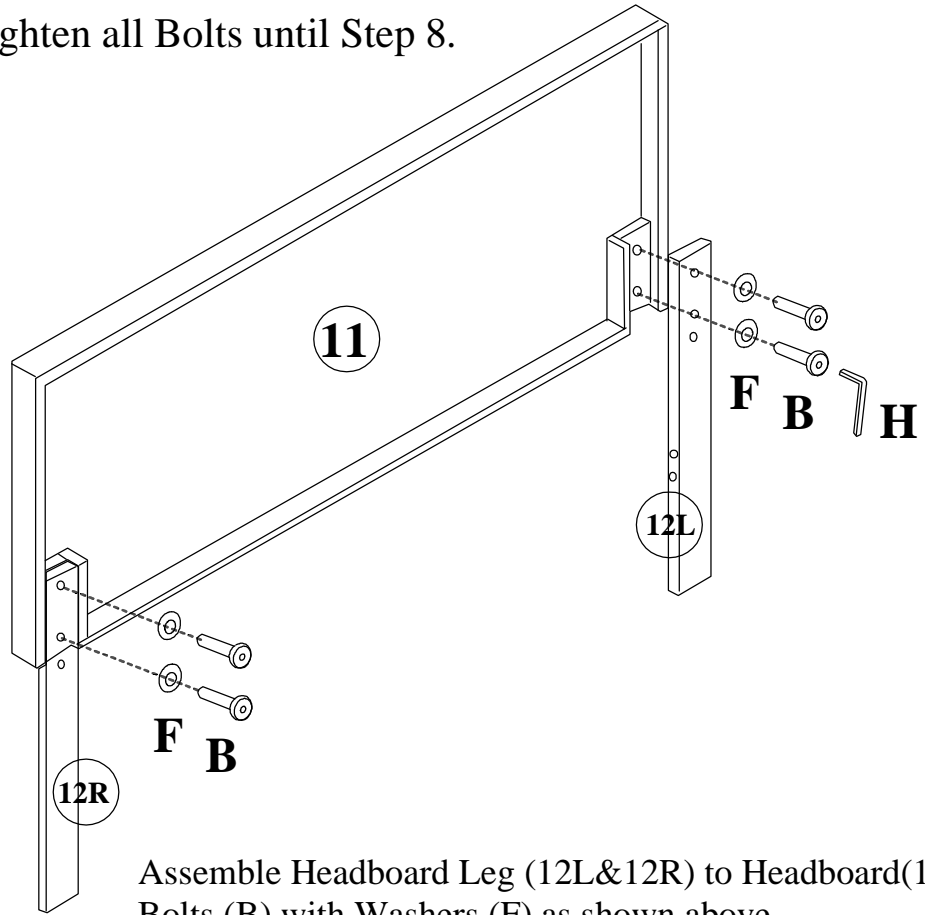
NOTE: Do not fully tighten all Bolts until Step 8.







	B x 4pcs
	F x 4pcs
	H x 1pc

Assemble Headboard Leg (12L&12R) to Headboard(11) using Bolts (B) with Washers (F) as shown above.

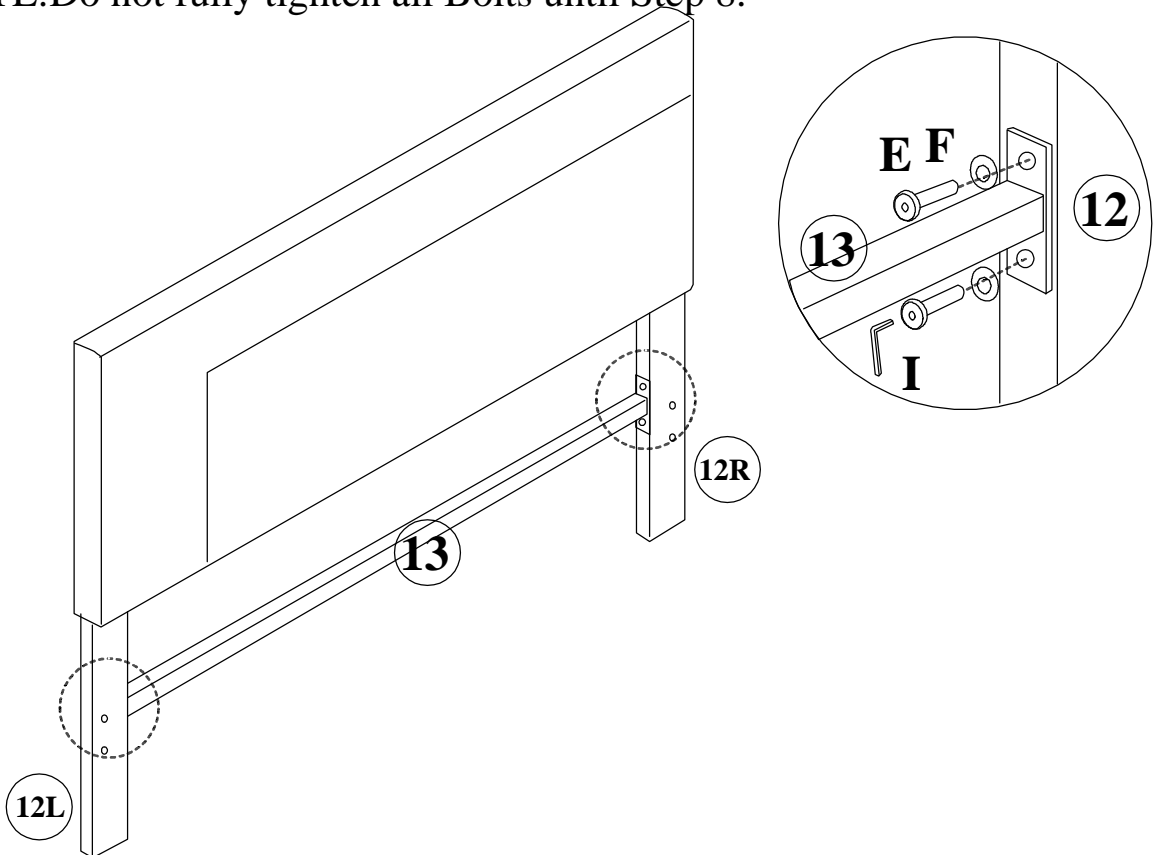
STEP 2

NOTE: Do not fully tighten all Bolts until Step 8.







	E x 4pcs
	F x 4pcs
	I x 1pc

Assemble Connect Bar (13) to Headboard Leg (12L&12R) using Bolts (E) with Washers (F) as shown above.

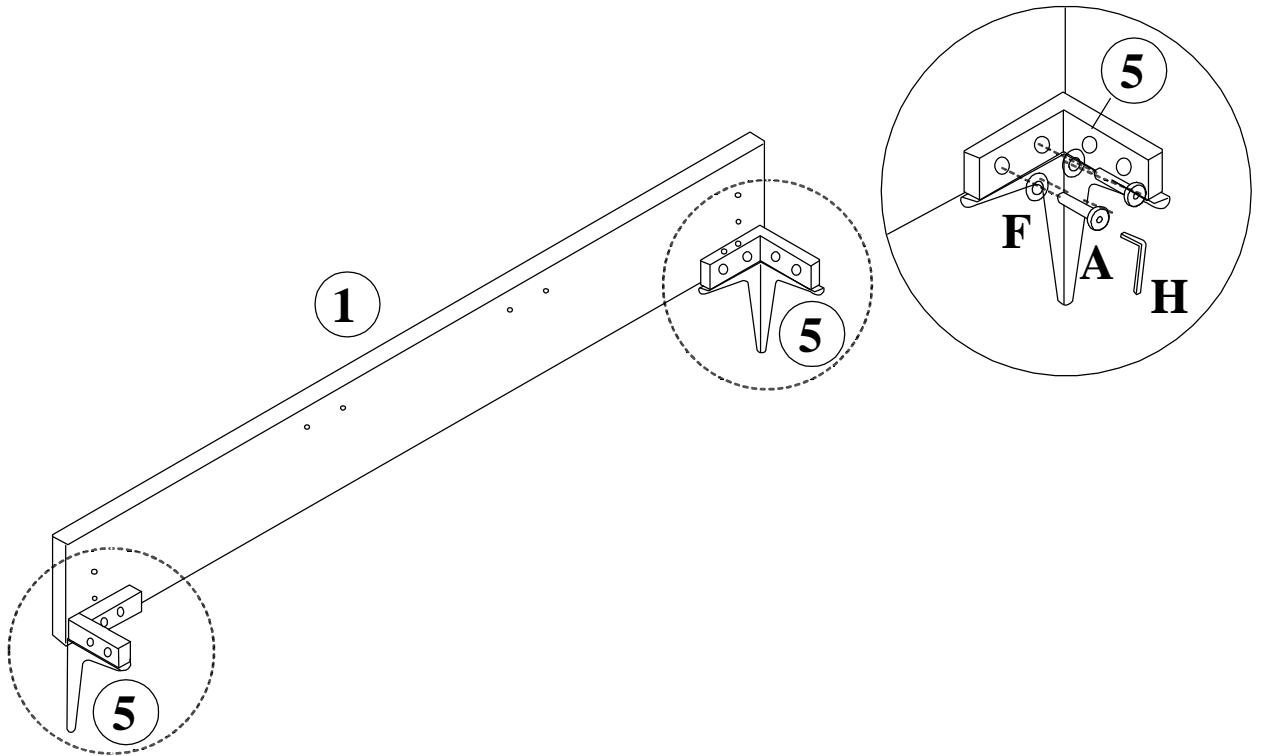
STEP 3

NOTE: Do not fully tighten all Bolts until Step 8.







	A x 4pcs
	F x 4pcs
	H x 1pc

Assemble Metal Legs(5) to Footboard(1) using Bolts(A) & Washers(F) as shown above.

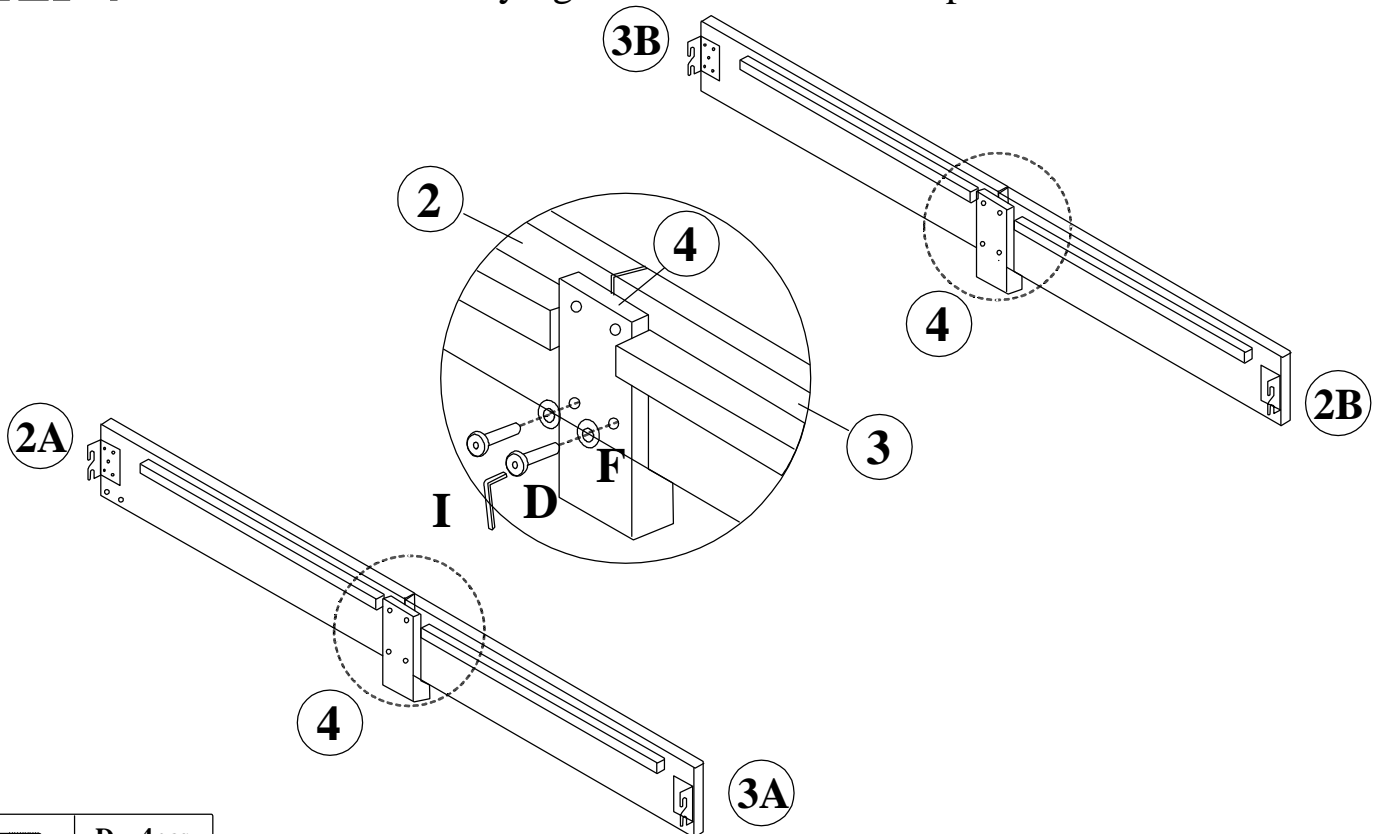
STEP 4

NOTE: Do not fully tighten all Bolts until Step 8.





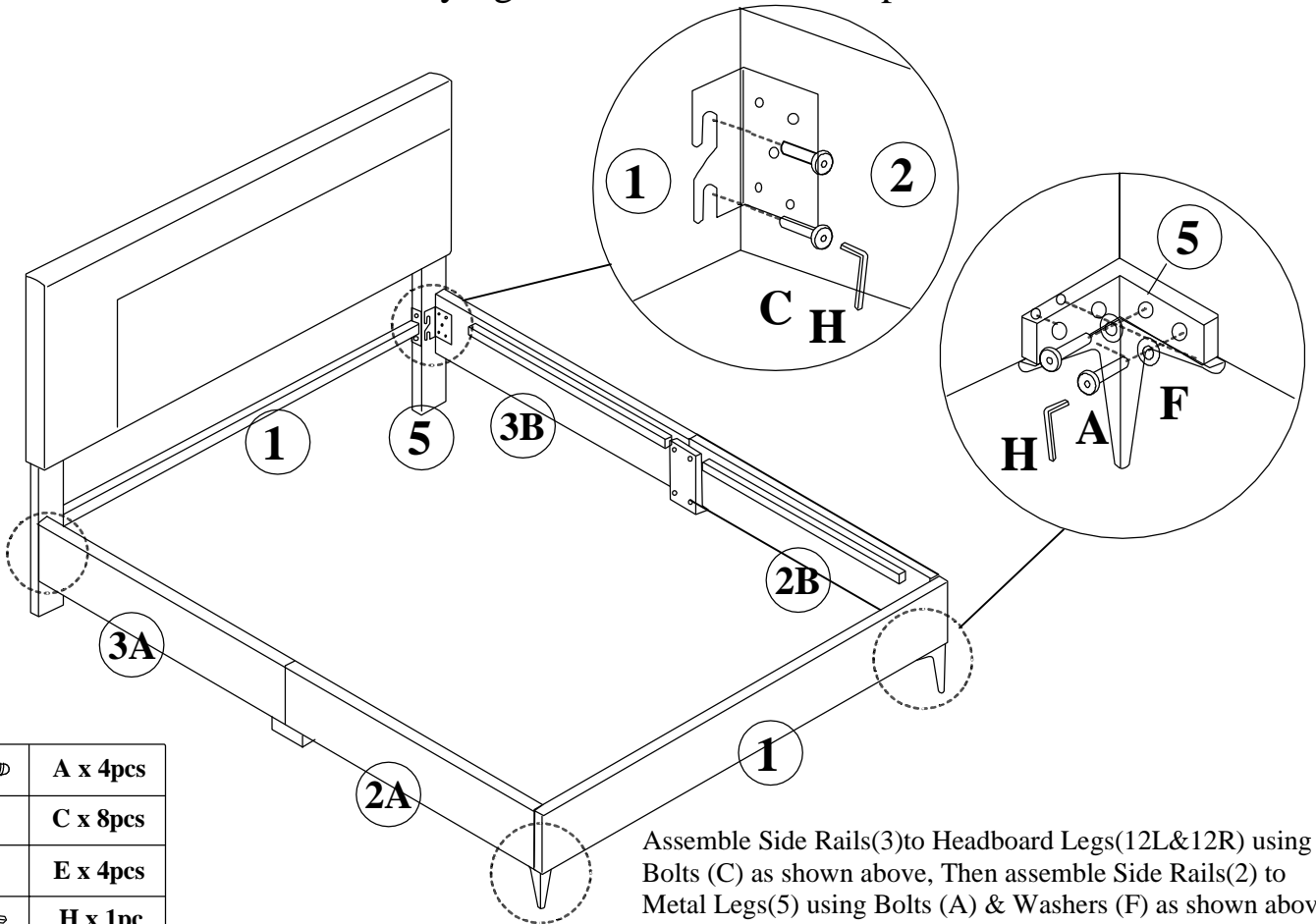

	D x 4pcs
	F x 4pcs
	I x 1pc

Assemble Side Legs(4) to Side boards(2A&3A&2B&3B) using Bolts (D) & Washers(F) as shown above.

STEP 5 NOTE: Do not fully tighten all Bolts until Step 8.





	A x 4pcs
	C x 8pcs
	E x 4pcs
	H x 1pc

Assemble Side Rails(3) to Headboard Legs(12L&12R) using Bolts (C) as shown above, Then assemble Side Rails(2) to Metal Legs(5) using Bolts (A) & Washers (F) as shown above.

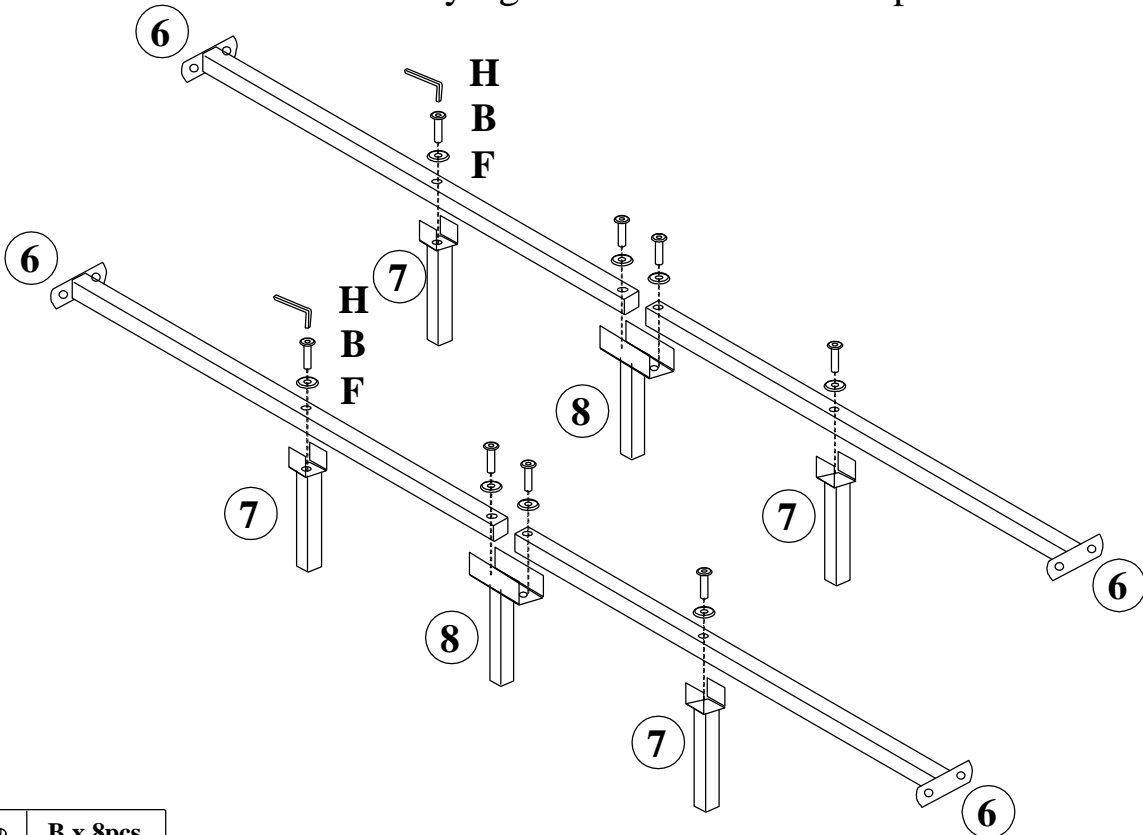
STEP 6 NOTE: Do not fully tighten all Bolts until Step 8.



	B x 8pcs
	F x 8pcs
	H x 1pc

Assemble Support Legs (7&8) to Center Rails (6) using Bolts (H) & Washers (F) as shown above.

STEP 7 NOTE: Do not fully tighten all Bolts until Step 8.

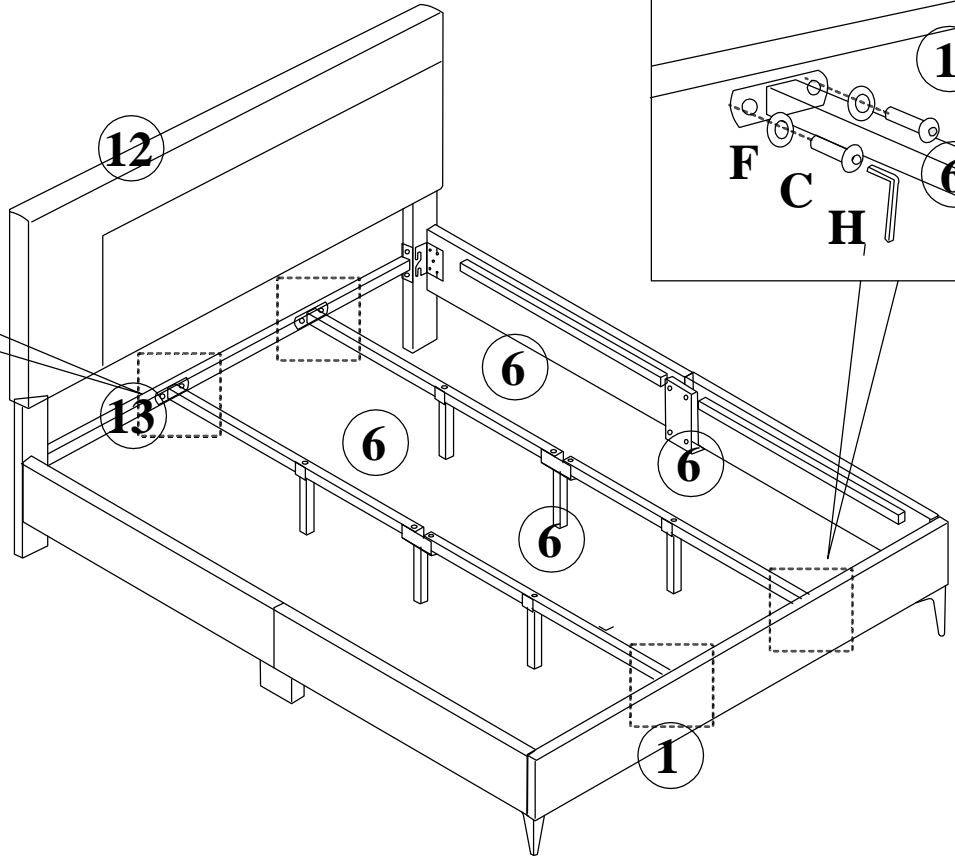
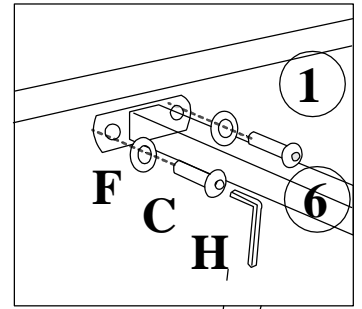
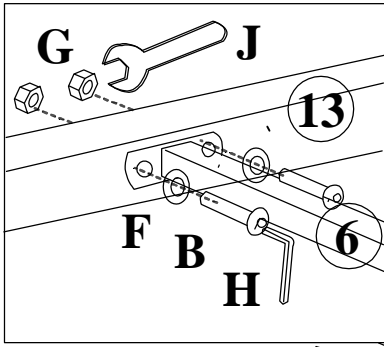

	B x 4pcs
	C x 4pcs
	F x 8pcs
	G x 4pcs
	H x 1pc
	J x 1pc

Assemble Center Rails(6) to Connect Bar(13) & FootBoard (1) using Bolts(C&B)& Nut(G) & Washers (F) as shown above.

STEP 8 NOTE: Tighten all Bolts at this point.

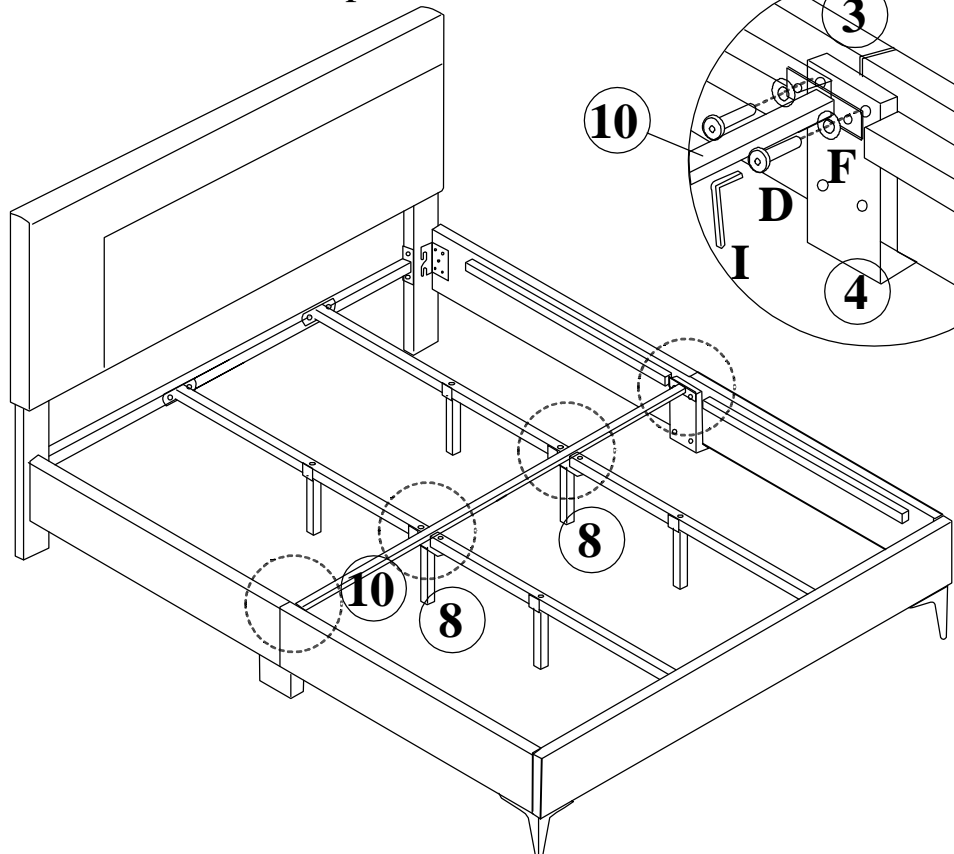
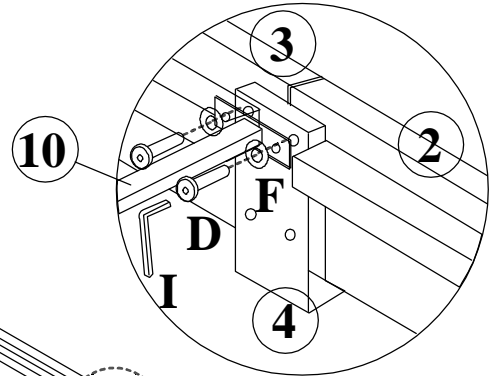
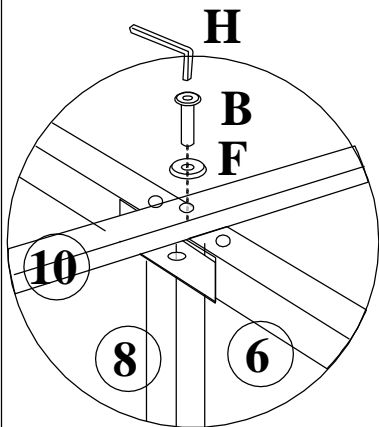

	B x 2pcs
	D x 4pcs
	F x 6pcs
	H x 1pc
	I x 1pc

Assemble Center Bar (10) to Side Legs(4) & Support Leg(8) using Bolts (B)&(D) & Washers (F) as shown above.

STEP 9

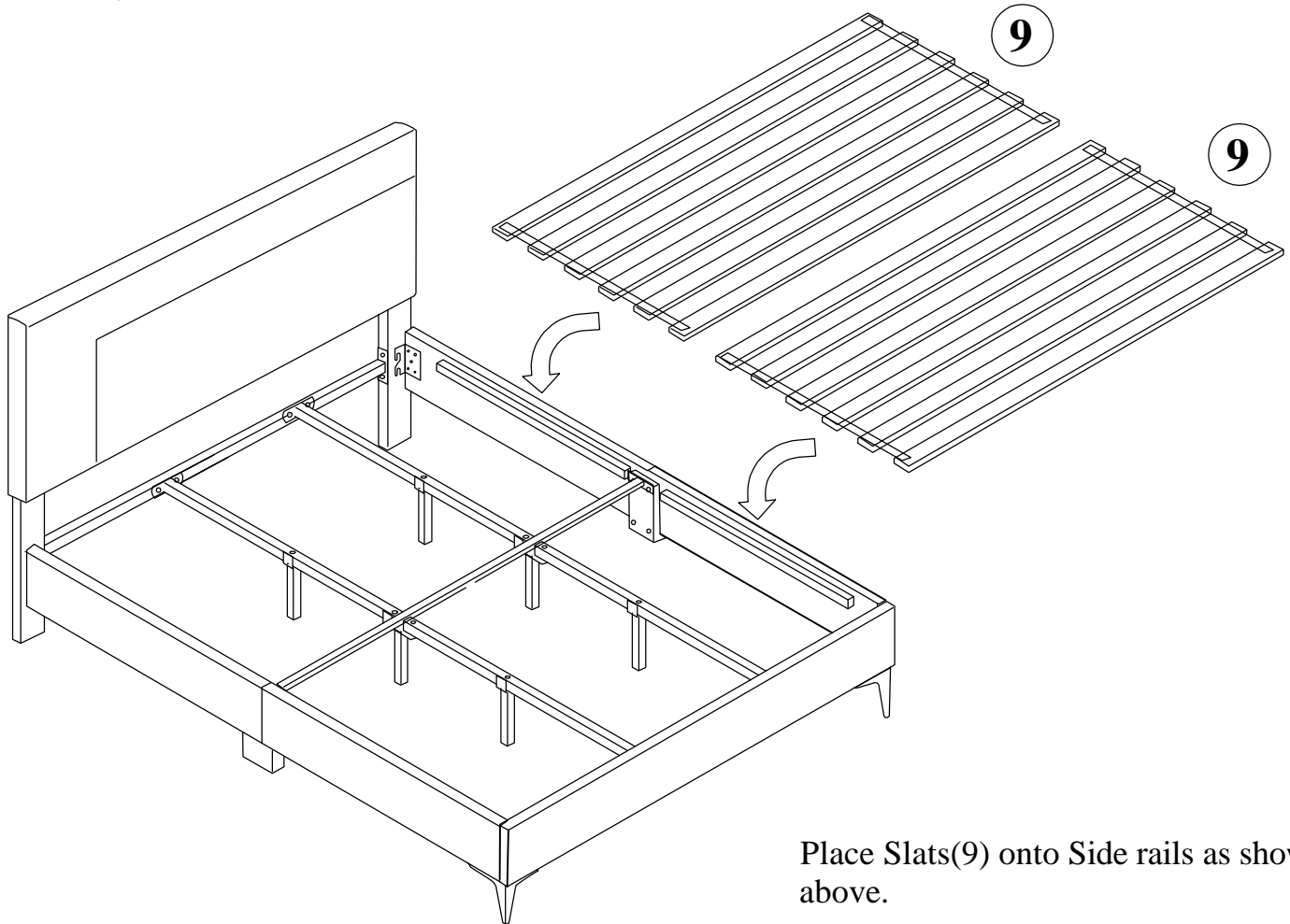

Place Slats(9) onto Side rails as shown above.

STEP 10

