





ASSEMBLY INSTRUCTIONS

MODEL : ME 0059A
QUEEN BED

(Box 1)

BOX OF HEADBOARD & FOOT

No	ITEM	Qty
A	Headboard 	1 pc
B	Footboard 	1 pc
C	Headboard Leg (L/R) 	2 pcs
D	Bed Slats 	4 pcs
E	Bed Slats Support 	4 pcs

(Box 2)

BOX OF SIDE RAIL

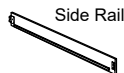
No	ITEM	Qty
F	Side Rail 	2 pcs

(Box 1)

HARDWARE LIST

No	ITEM	Qty
1	Csk M4 x 32mm 	8 pcs
2	JCBC M6 x 30mm 	6 pcs
3	SPRING WASHER 1/4" Blk 	6 pcs
4	Flat Washer 1/4"ID x 13mmOD Blk 	6 pcs
5	ALLEN KEY M4 x 65mm Blk 	1 pc
6	ALLEN KEY M5 x 65mm Blk 	1 pc

STEP 1 : Attach Headboard Leg (C) to Headboard (A) as shown using JCBC Bolt (2)with Spring Washer (3), Flat washer (4) and securing with Allen Key (5).

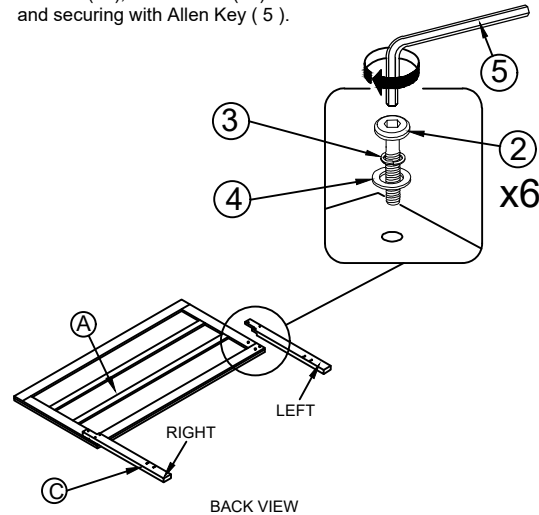

STEP 2 : Hook Side Rail (F) to Headboard (A) closely and push down to fit. repeat step 3 with other end of rail to hook onto Footboard (B).

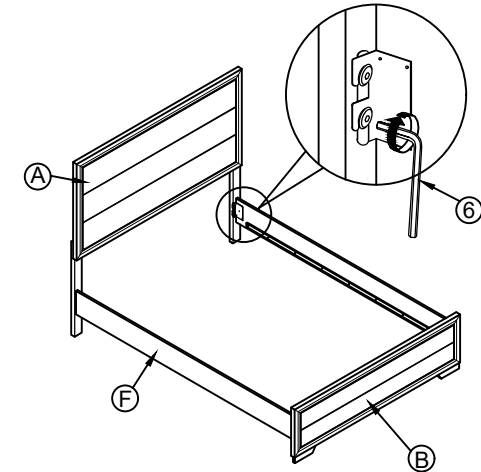

STEP 3 : Tighten the 4 Corner with Allen Key (6). Fix the Bed Slat Support Leg (E), to Bed Slat (D) as shown. Install the bed slat (D) to side rail (F) and tighten with Csk Screw (1) as per diagram shown. (NOTE: THE SETUP MUST DONE AT THE DECIDED LOCATION FOR THE BED TO OBTAIN PERFECT STABILITY)

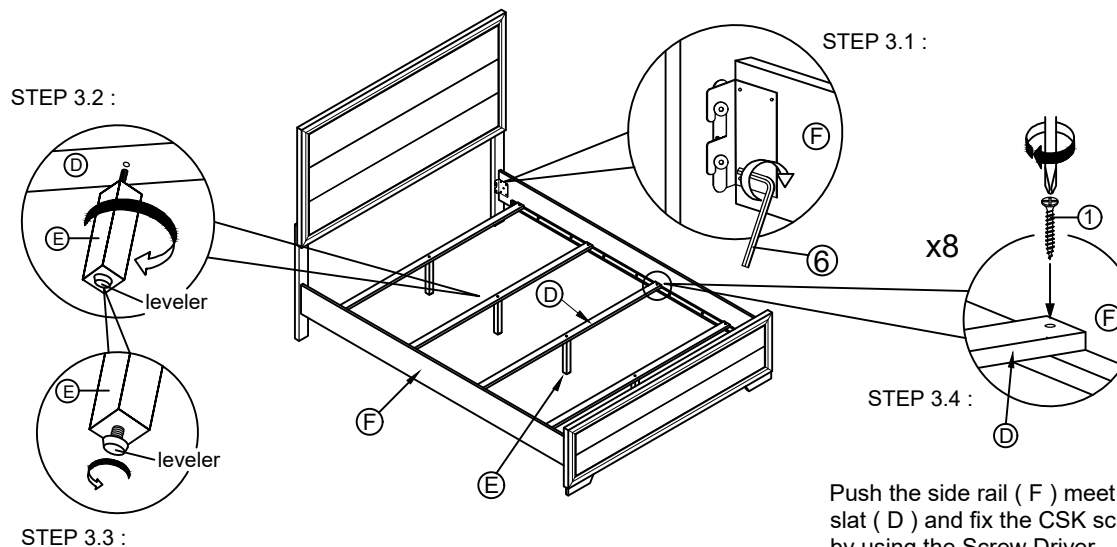

COMPLETED
ASSEMBLY

Push the side rail (F) meet with wooden slat (D) and fix the CSK screw (1) by using the Screw Driver.

NOTE : MUST TIGHTEN SCREWS PERIODCALLY WITH USE SCREW WILL BECOME LOOSE CHECK TIGHTNESS OF ALL SCREW EVERY 6-8 WEEKS.