











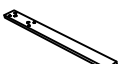

ASSEMBLY INSTRUCTIONS

MODEL : 0401A
QUEEN/FULL (4+4)

(Box 1)
BOX OF HEADBOARD & FOOTBOARD

| No | ITEM | Qty |
|----|---|-------|
| A | Headboard  | 1 pc |
| B | Footboard  | 1 pc |
| C | Headboard Leg  | 2 pcs |
| D | Bed Slats  | 4 pcs |
| E | Bed Slats Support  | 4 pcs |
| F | Side Rail  | 2 pcs |

(Box 1)
HARDWARE LIST

| No | ITEM | Qty |
|----|---|--------|
| 1 | JCBC M6 x 40mm  | 4 pcs |
| 2 | SPRING WASHER 1/4" Blk  | 4 pcs |
| 3 | Flat Washer 1/4"ID x 13mmOD Blk  | 4 pcs |
| 4 | ALLEN KEY m4x65mm Blk  | 1 pc |
| 5 | ALLEN KEY m5x65mm Blk  | 1 pc |
| 6 | Flat Head Chipboard Screw m4x32mm Rbw  | 16 pcs |

STEP 1.1 Attach Head Board Leg (C) to Head Board (A) as shown using JCBC BOLT(1)with Spring Washer (2), Flat washer (3)and securing with ALLEN KEY (4) .

STEP 1.2 : Fix the other holes with Csk Screw (6) as shown.

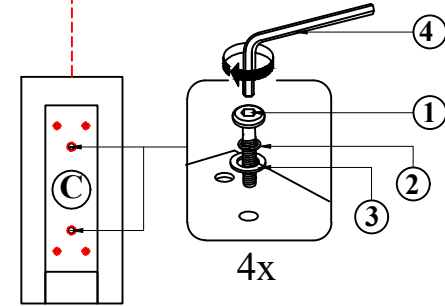
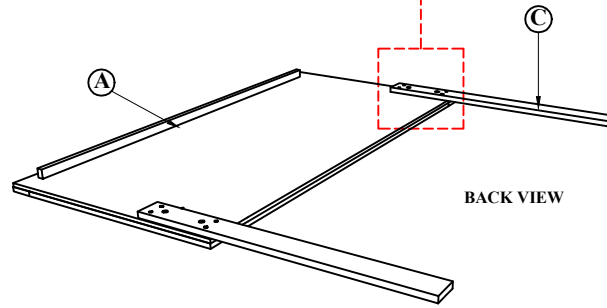

STEP 1.1 :

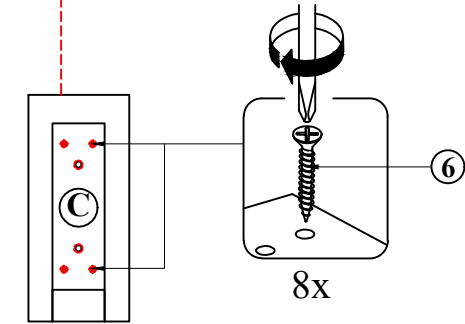

STEP 1.2 :

STEP 2 : Hook SIDE RAIL(F) TO HEAD BOARD (A) closely and push down to fit. repeat step 2 with other end of rail to hook onto FOOTBOARD (B).

STEP 2.2 :

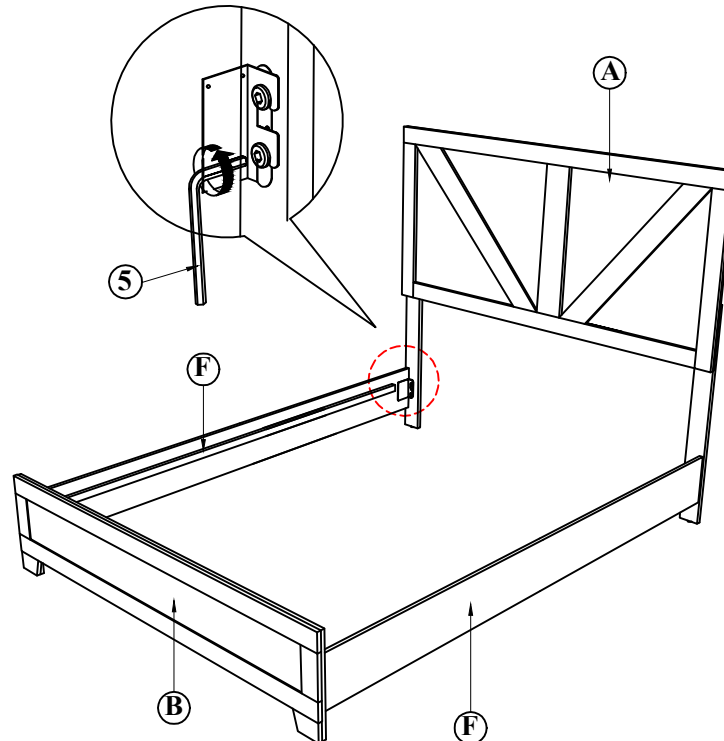

STEP 3 : Tighten the 4 Corner with Allen Key (5).Fix the Bed Slat Support Leg (E) , to Bed Slat (D) as shown . Install the bed slat (D) to side rail (F) and tighten with Csk Screw (6) as per diagram shown. (NOTE: THE SETUP MUST DONE AT THE DECIDED LOCATION FOR THE BED TO OBTAIN PERFECT STABILITY)

STEP 3.2 :

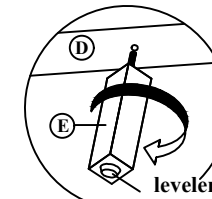

STEP 3.1 :

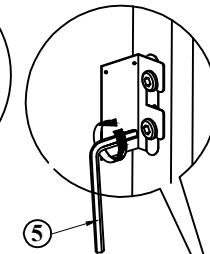

STEP 3.3 :

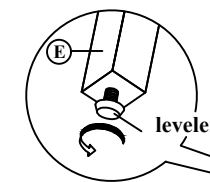

STEP 3.4 :

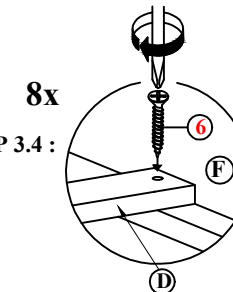

Push the side rail(F) meet with wooden slat(D) and fix the CSK screw (6) by using the Screw Driver.

COMPLETE ASSEMBLY