

ASSEMBLY INSTRUCTION

**MODEL:0401A
DRESSER & MIRROR**

(Box 1)

BOX OF MIRROR

NO	ITEM	Qty
A	MIRROR	1 PC
B	MIRROR SUPPORT	2PCS

(Box. 2)

BOX OF DRESSER

NO	ITEM	Qty
C	DRESSER	1 PC

(Box. 1)

HARDWARE LIST

NO	ITEM	Qty
1	Flat Head Chipboard Screw m4x32mm Rbw	8 PCS

STEP 1: Remove mirror support (B) from carton

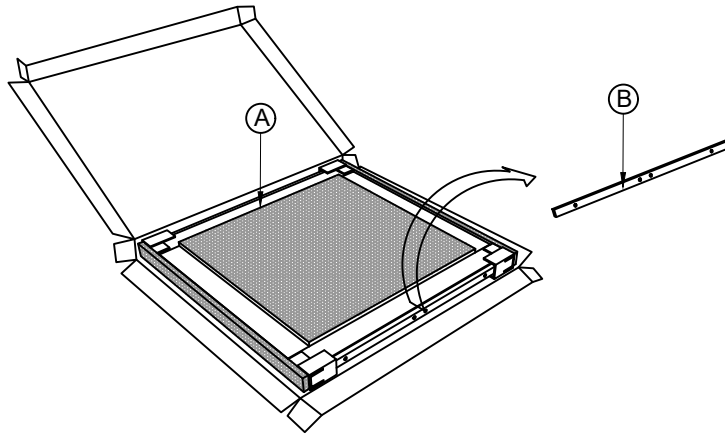

STEP 2: Align mirror support (B) by follow the line marking provided. Then fasten with Csk screw (1) securing them by using screw driver (NOT PROVIDED).

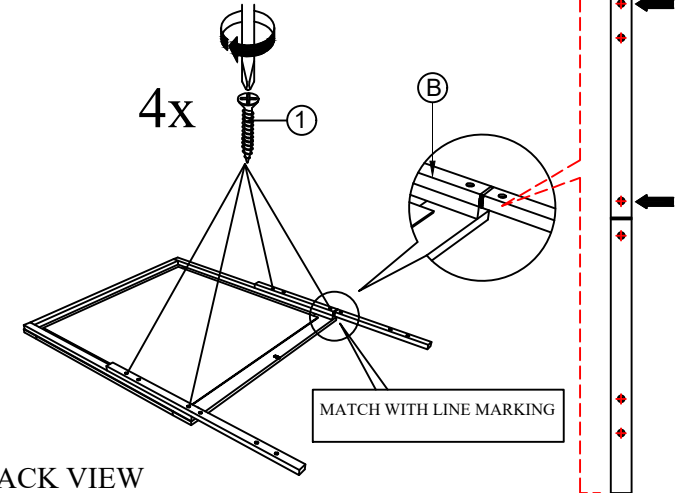

STEP 3: Place mirror (A) on top of dresser (C). Align & fasten mirror support (B) to the back of dresser (C) using Csk Screw (1) with Srew with screw driver.(NOT PROVIDED)

Note : Make sure marking mirror must align with the dresser marking as shown.

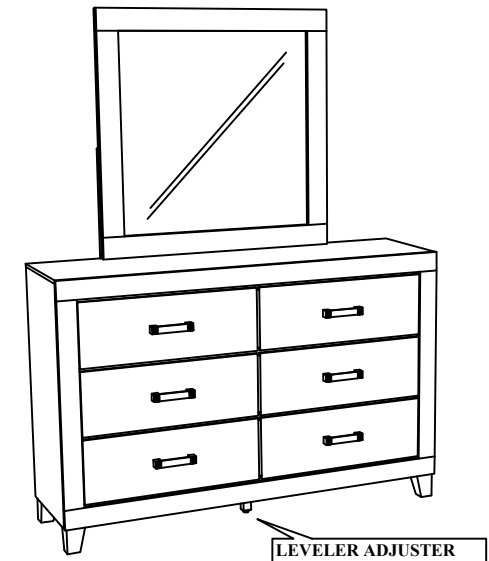
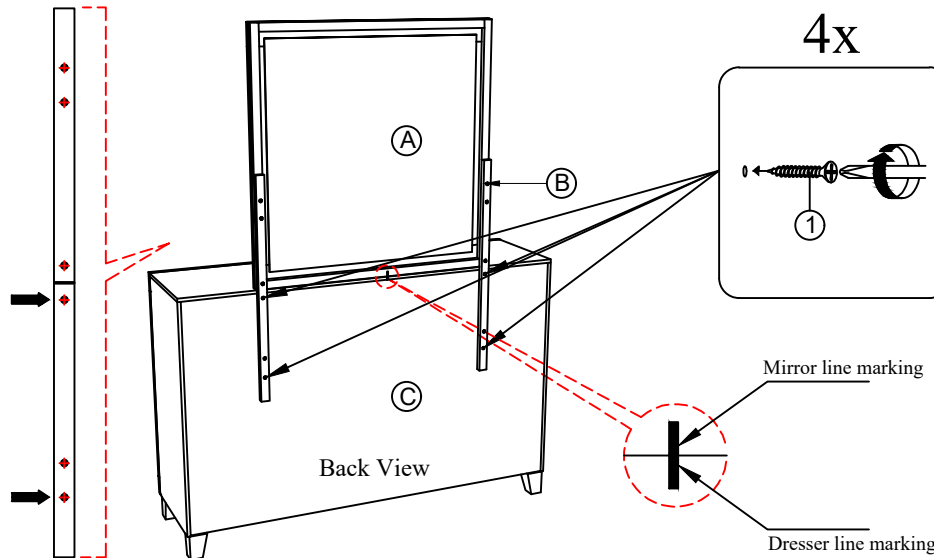

COMPLETED ASSEMBLY

NOTE : MUST TIGHTEN SCREWS PERIODCALLY WITH USE SCREW WILL BECOME LOOSE CHECK TIGHTNESS OF ALL SCREW EVERY 6-8 WEEKS.