



ASSEMBLY INSTRUCTIONS

**MODEL : 0401A
CHEST**

STEP 1 : Pull the bottom drawer and take out the Bunfoot carton (B). Assemble the Bun Foot (B) with JCBC Bolt (1),Spring washer (2),Flatwasher (3) and securing with Allen Key (4) as shown.





(BOX 1)

BOX OF CHEST

NO	ITEM	QTY
A	CHEST 	1 pc
B	BUN FOOT 	4 pcs

(BOX 1)

HARDWARE LIST

NO	ITEM	QTY
1	JCBC Bolt m6x50mm Blk 	4 pcs
2	Spring Washer 1/4" Blk 	4 pcs
3	Flat Washer 1/4"IDx13mmOD Blk 	4 pcs
4	Allen Key m4x110mm With Ball Blk 	1 pc

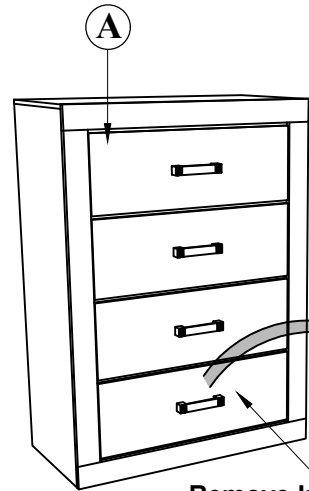

Remove Inner box leg

Hardware Pack

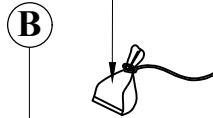

x4

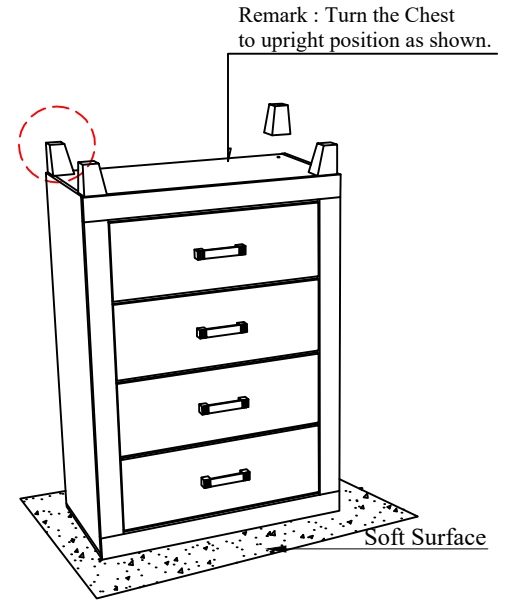
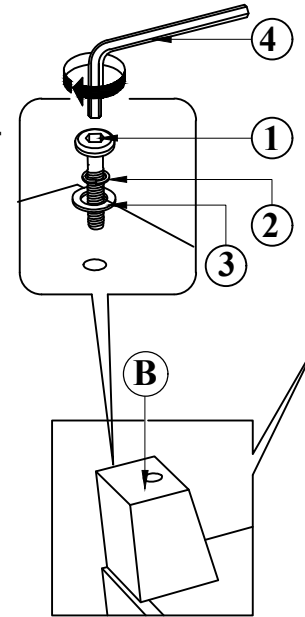

Soft Surface

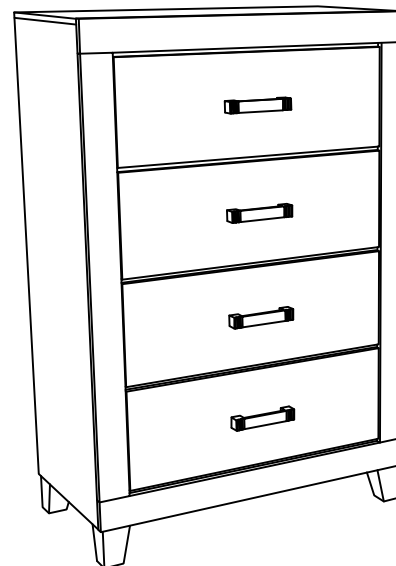

COMPLETED ASSEMBLY

NOTE : MUST TIGHTEN SCREWS **PERIODICALLY** WITH USE SCREW WILL BECOME LOOSE CHECK TIGHTNESS OF ALL SCREW EVERY 6-8 WEEKS.