







# ASSEMBLY INSTRUCTIONS

**MODEL : 0286A  
CHEST**

**(BOX 1)  
BOX OF CHEST**

NO	ITEM	QTY
A	CHEST 	1 pc
B	BUN FOOT 	4 pcs

**(BOX 1)  
HARDWARE LIST**

NO	ITEM	QTY
1	JCBC Bolt m6x100mm Blk 	4 pcs
2	Spring Washer 1/4" Blk 	4 pcs
3	Flat Washer 1/4"IDx13mmOD Blk 	4 pcs
4	Allen Key m-4x110mm With Ball Blk 	1 pc

**STEP 1 :**

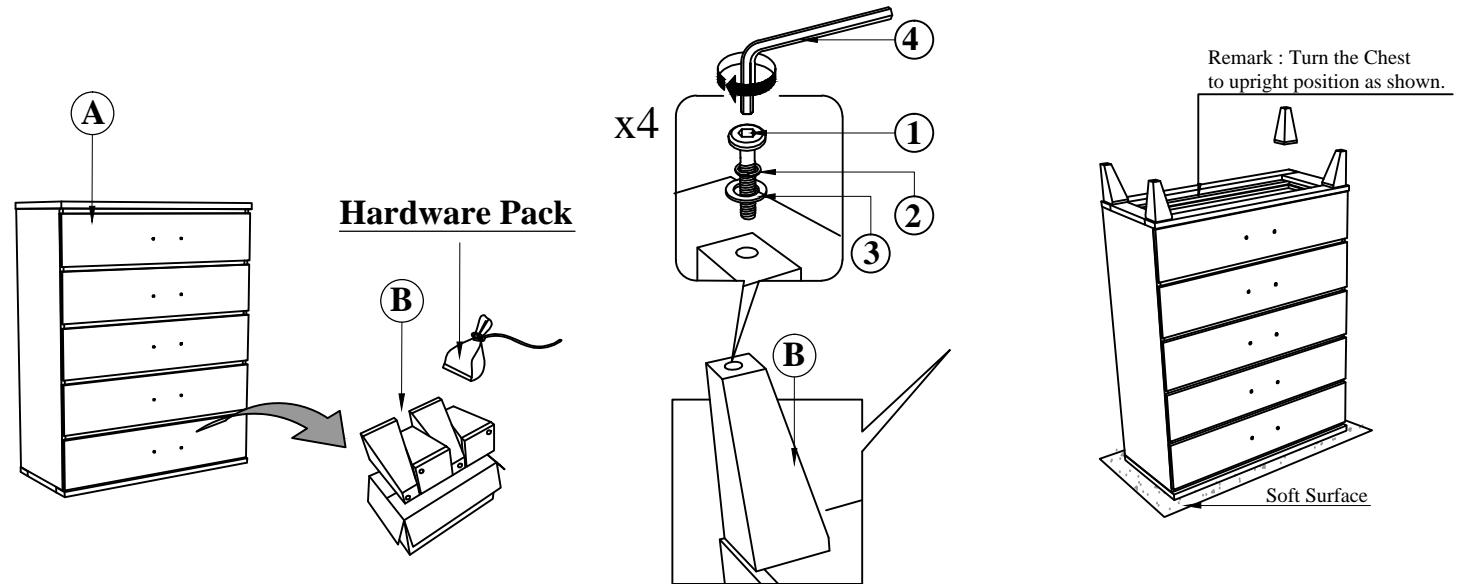

**STEP 2 :** Reinstall the Handle from Inside to outside Drawer Front as shown.

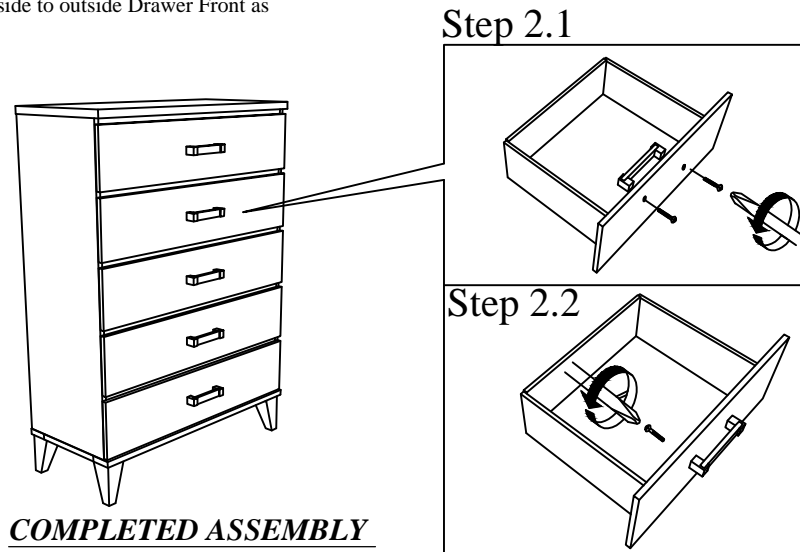

**COMPLETED ASSEMBLY**

**NOTE :** MUST TIGHTEN SCREWS **PERIODICALLY** WITH USE SCREW WILL BECOME LOOSE CHECK TIGHTNESS OF ALL SCREW EVERY 6-8 WEEKS.