

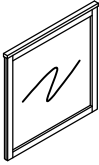

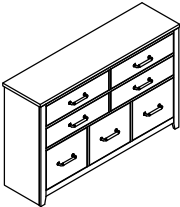



# ASSEMBLY INSTRUCTIONS

**MODEL : FBDSRA-157A+ FBMIRR-157A**

**REVISION : B**

No	Parts & Hardware	Qty
A	Mirror 	1 Pc
B	Dresser 	1 Pc
C	Mirror Support 	2 Pcs
D	Dresser Support 	1 Pc
E	JCBC Screw M6 x 35mm 	8 Pcs
F	Spring Washer Ø1/4" 	8 Pcs
G	Flat Washer Ø1/4" x 20mm 	8 Pcs
H	L Key M4 x 65mm 	1 Pc

## STEP 1

Attach Mirror Support (C) to the Mirror back (A), using JCBC M6 x35mm (E) with Spring Washer  $\text{Ø}\frac{1}{4}$ " (F) , Flat Washer  $\text{Ø}\frac{1}{4}$ " x 20mm (G). Tighten using L Key M4 (H). Make sure the marking line on mirror support is at the same level as the bottom of mirror.

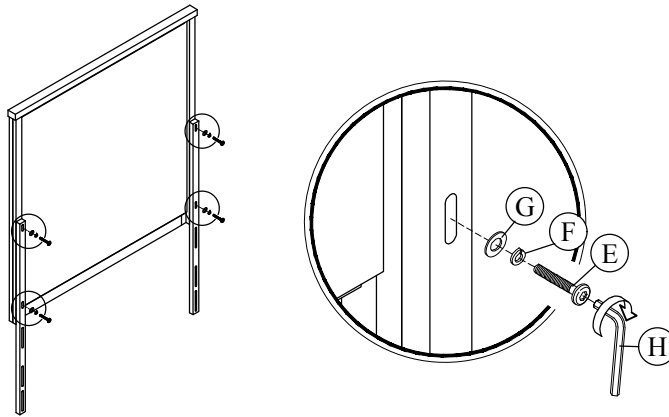

## STEP 2

Place the mirror with support on the top of Dresser (B). Then *align center* as shown and using JCBC M6 x35mm (E) with Spring Washer  $\text{Ø}\frac{1}{4}$ " (F) , Flat Washer  $\text{Ø}\frac{1}{4}$ " x 20mm (G). Tighten using L Key M4 (H).

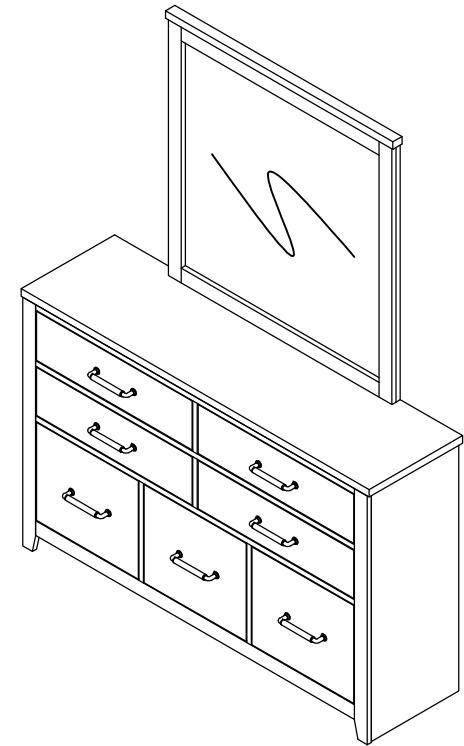
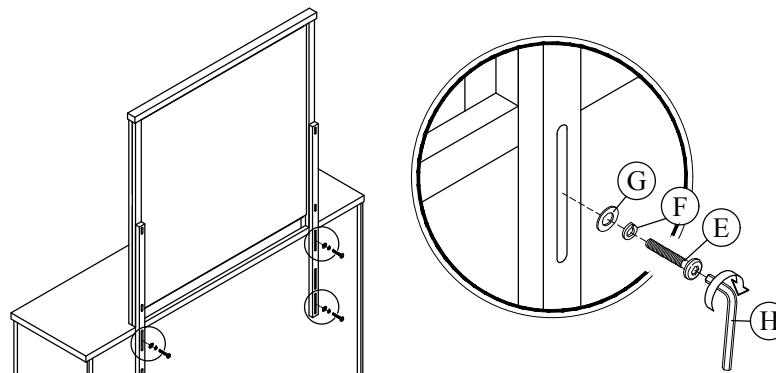

## STEP 3

## STEP 3

Install the Dresser Support (D) to the product. Adjust according to the ground level.

