

# ASSEMBLY INSTRUCTIONS

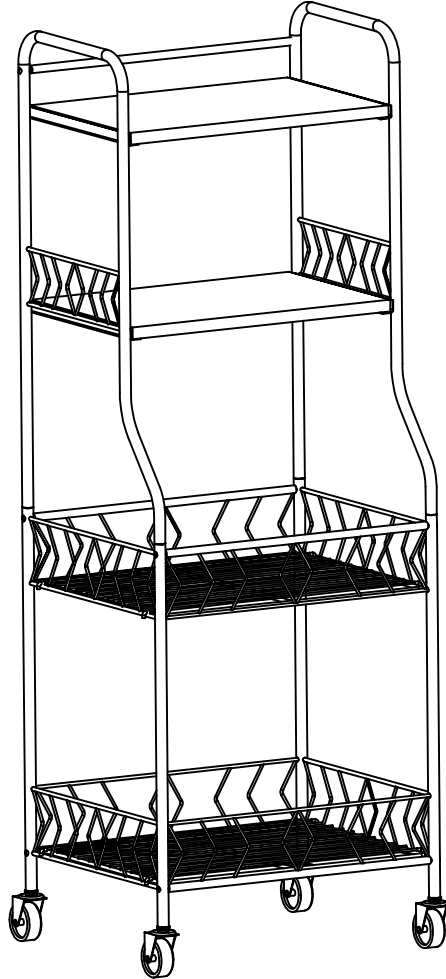



## Style # K3024 Bakers Rack

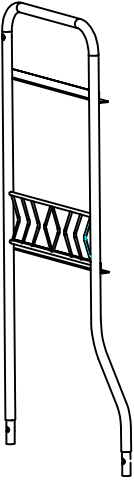
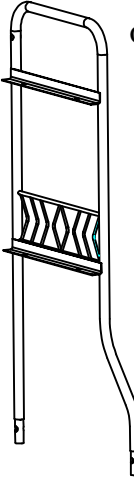
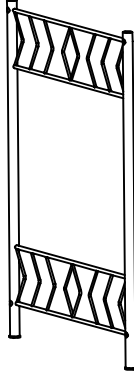

### NOTE TO CUSTOMERS:

- For ease and speed of assembly we recommend that before you commence each step of the assembly that you identify all the parts required to complete that step.
- We recommend that where possible you allow sufficient space to assemble the item as close as possible to the place where it will be once assembled.
- For the protection of your furniture we recommend that the product is placed on protected surfaces during assembly to prevent any damage.
- During assembly do not over tighten, as this may damage the product.
- Please ensure you retain all the product packaging until the item completely assembled.
- Please periodically check all fittings and re-tighten as necessary.
- It is recommended that this item should be assembled by two adults.

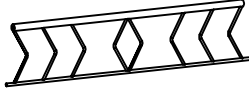



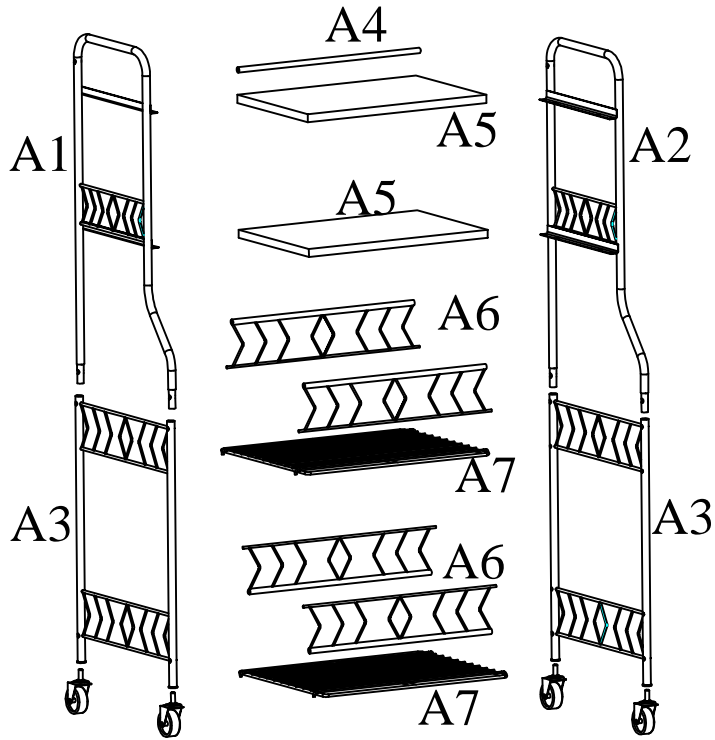

# Part List

<p>A1</p>  <p>Quantity of 1</p> <p>Upper Left Frame</p>	<p>A2</p>  <p>Quantity of 1</p> <p>Upper Right Frame</p>	<p>A3</p>  <p>Quantity of 2</p> <p>Lower Frame</p>
<p>A4</p>  <p>Quantity of 1</p> <p>Connect Bar</p>	<p>A5</p>  <p>Quantity of 2</p> <p>Shelf Panel</p>	<p>A6</p>  <p>Quantity of 4</p> <p>Apron</p>
<p>A7</p>  <p>Quantity of 2</p> <p>Metal Wire Net</p>		

# Part List



# Hardware List

<p>B1</p> <p>Quantity of 10</p>  <p>1/4"*1"</p> <p>Bolt</p>	<p>B2</p> <p>Quantity of 8</p>  <p>1/8"*0.375"</p> <p>Screw</p>	<p>B3</p> <p>Quantity of 2</p>  <p>Wheel</p>	<p>B4</p> <p>Quantity of 2</p>  <p>Wheel with brake</p>
 <p>Open Wrench</p>	 <p>Allen Wrench</p>		

# Assembly Instructions

Step 1:

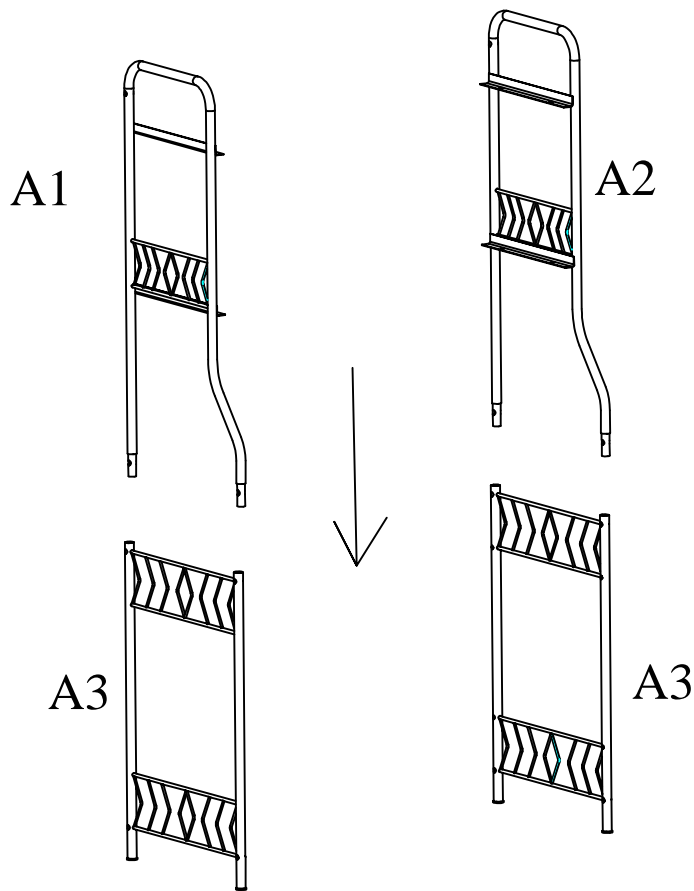

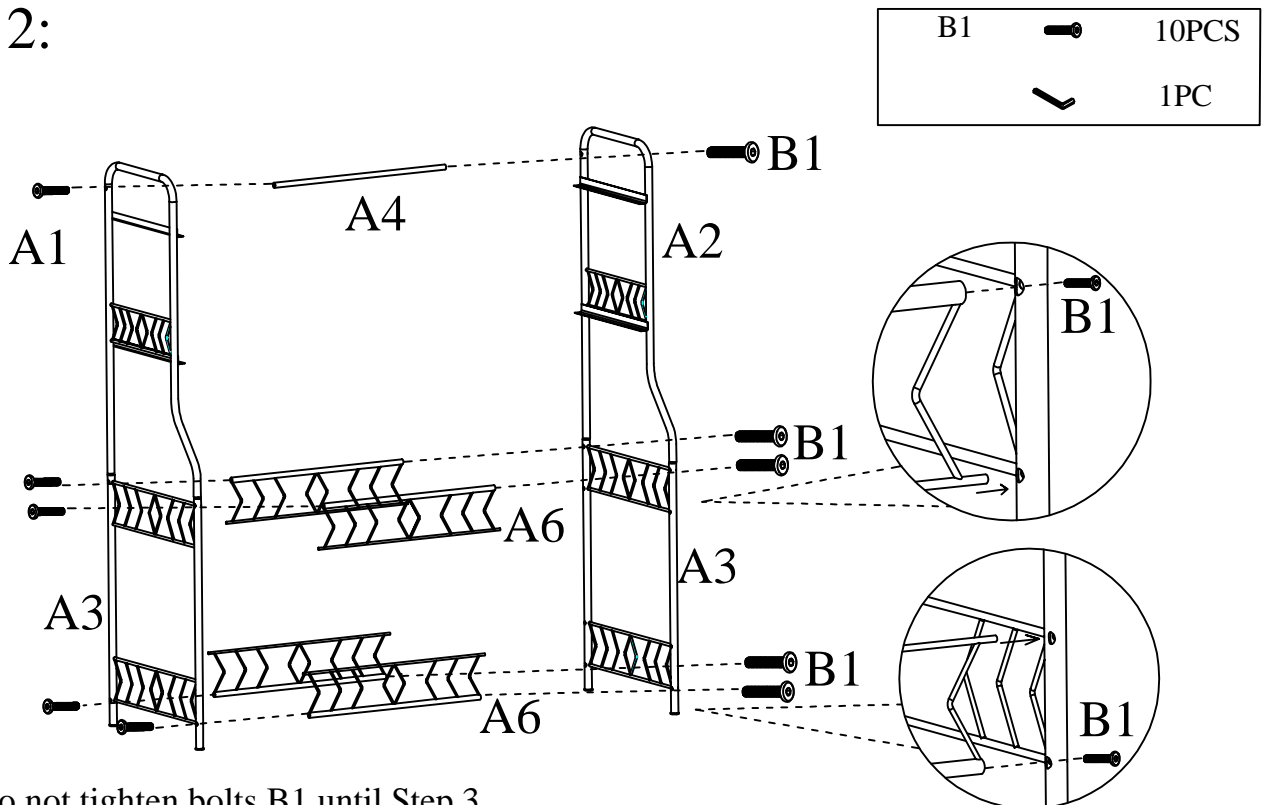

Step 2:



Do not tighten bolts B1 until Step 3.

### Step 3:

B3		2PCS
B4		2PCS
		

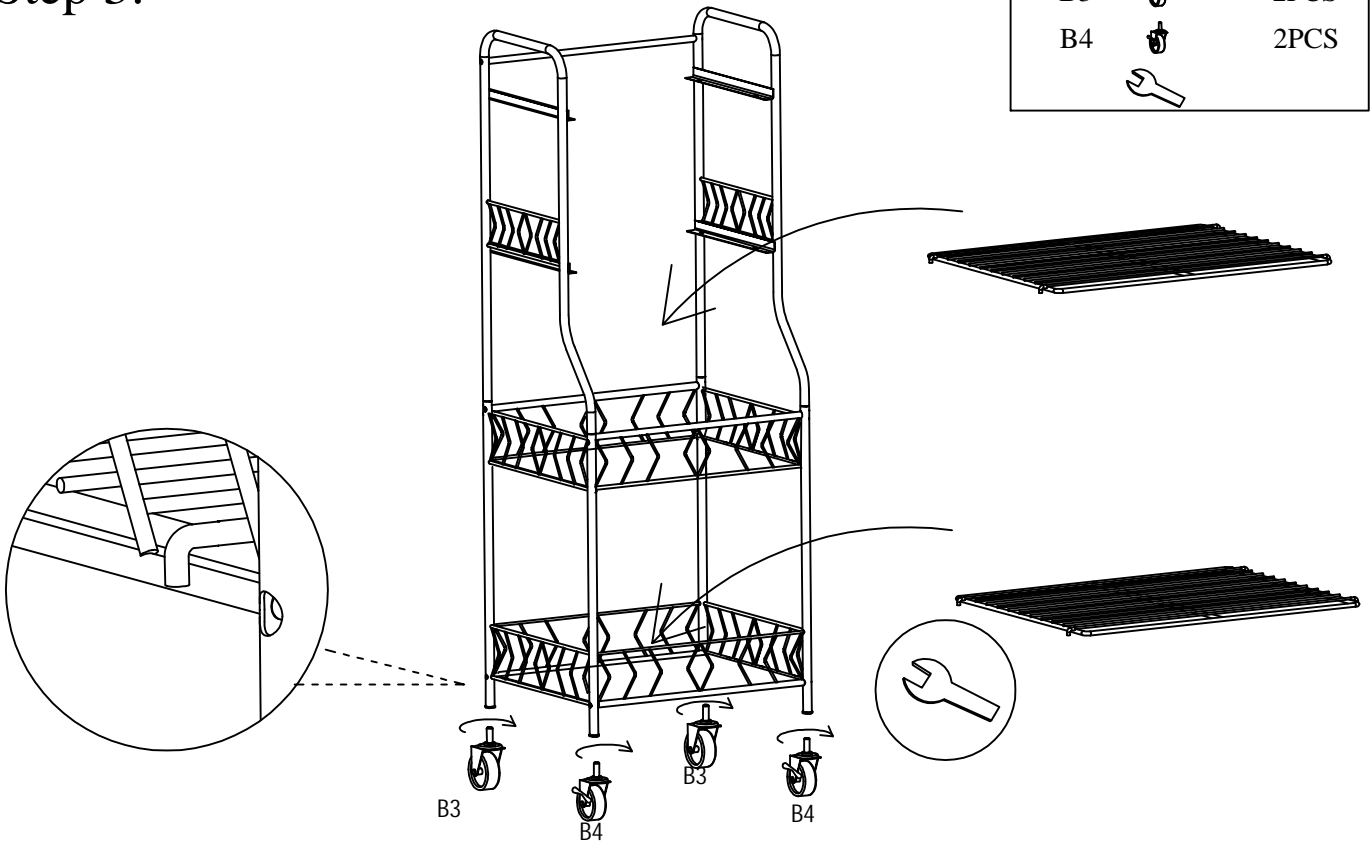

Tighten the bolts B1 at this point .

### Step 4:

B2		8PCS
----	---	------

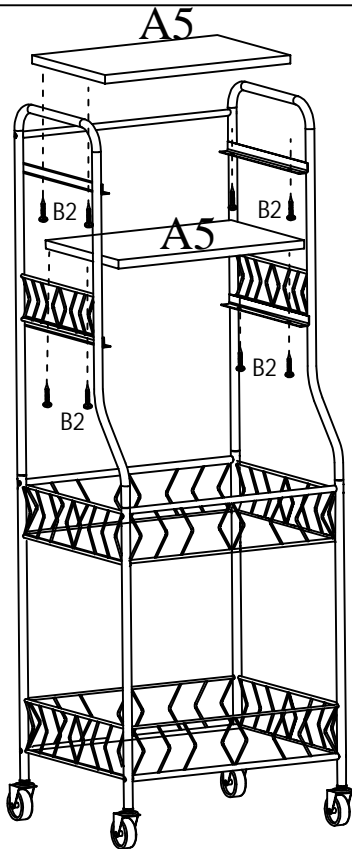

Step 5:

