

ASSEMBLY INSTRUCTIONS

Style # 1145BL-E/1145WH-E Side Table

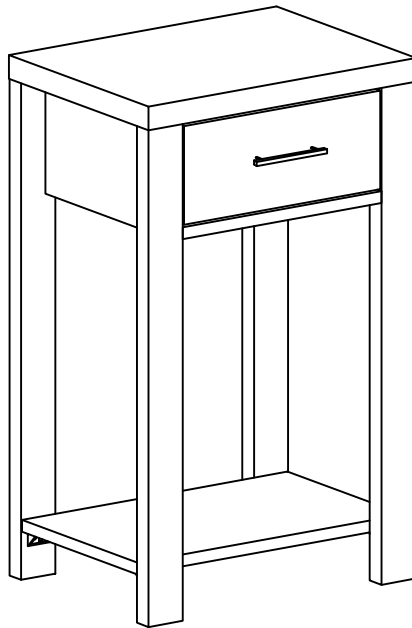

NOTE TO CUSTOMERS:

- For ease and speed of assembly we recommend that before you commence each step of the assembly that you identify all the parts required to complete that step.
- We recommend that where possible you allow sufficient space to assemble the item as close as possible to the place where it will be once assembled.
- For the protection of your furniture we recommend that the product is placed on protected surfaces during assembly to prevent any damage.
- During assembly do not over tighten, as this may damage the product.
- Please ensure you retain all the product packaging until the item completely assembled.
- Please periodically check all fittings and re-tighten as necessary.
- It is recommended that this item should be assembled by two adults.

To insert a cam lock: (Please read below instructions before assembling)

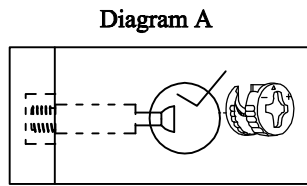
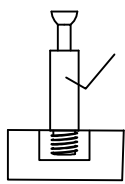

Diagram A

1. Insert cam screw into hole as shown in diagram A .

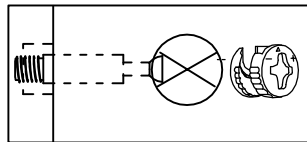
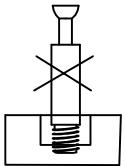

Diagram B

Make sure not to insert the cam screw:
Too deep as shown in figure B as this will cause the cam screw to be misaligned and unable to interlock properly.

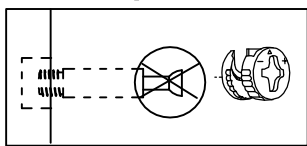
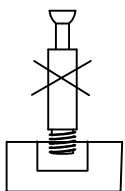
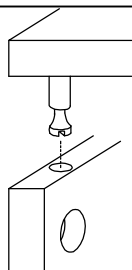
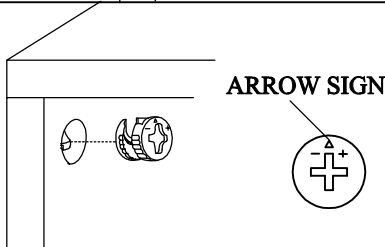

Diagram C

Also avoid inserting the cam screw too close to the surface of the hole as shown in figure C, as this will cause the cam lock to be too loose, and not interlock properly.



2. Connect the panels together.



3. When inserting the cam lock make sure the arrow of the cam lock faces the cam screw.

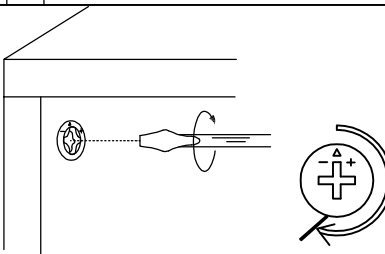











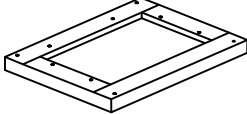
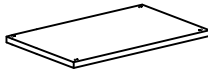

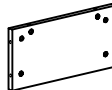
4. To tighten the cam lock turn the cam lock clockwise 90-180 degree or until the arrow is facing opposite the place cam lock was inserted.

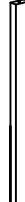
NOTE: DO NOT USE AN AUTOMATIC SCREWDRIVER TO TIGHTEN CAM LOCKS.





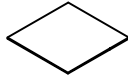

Note:

- Read these instructions carefully before assembling.
- Tools required : Phillips screwdriver, flat screwdriver.
- Find a clean, smooth area on which to work , such as a carpet, in order to avoid scratching the wood surfaces.
- Wait to dispose of the packing material until assembly is complete and all parts and hardware are accounted for.
- Two or more people might be required for assembly.

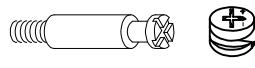
Part List

A Quantity of 1  Top Panel	B Quantity of 1  Bottom Shelf	C Quantity of 1  Side Panel(Left)	D Quantity of 1  Side Panel(Right)
E Quantity of 1  Back Panel	F Quantity of 1  Connect Bar	G Quantity of 1  Front Leg	H Quantity of 1  Front Leg
I Quantity of 1  Rear Leg	J Quantity of 1  Rear Leg	K Quantity of 1  Drawer Side Panel(Left)	L Quantity of 1  Drawer Side Panel(Right)
M Quantity of 1  Drawer Back Panel	N Quantity of 1  Drawer Bottom Panel	O Quantity of 1  Drawer Front Panel	

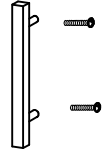
Hardware List

1 Quantity of 24  Camlock	2 Quantity of 6  Wood Dowel	3 Quantity of 4  Bolt	4 Quantity of 16  Screw
5 Quantity of 4  Connect Block	6 Quantity of 1  Handle with Bolt	 Allen Wrench	

Part List

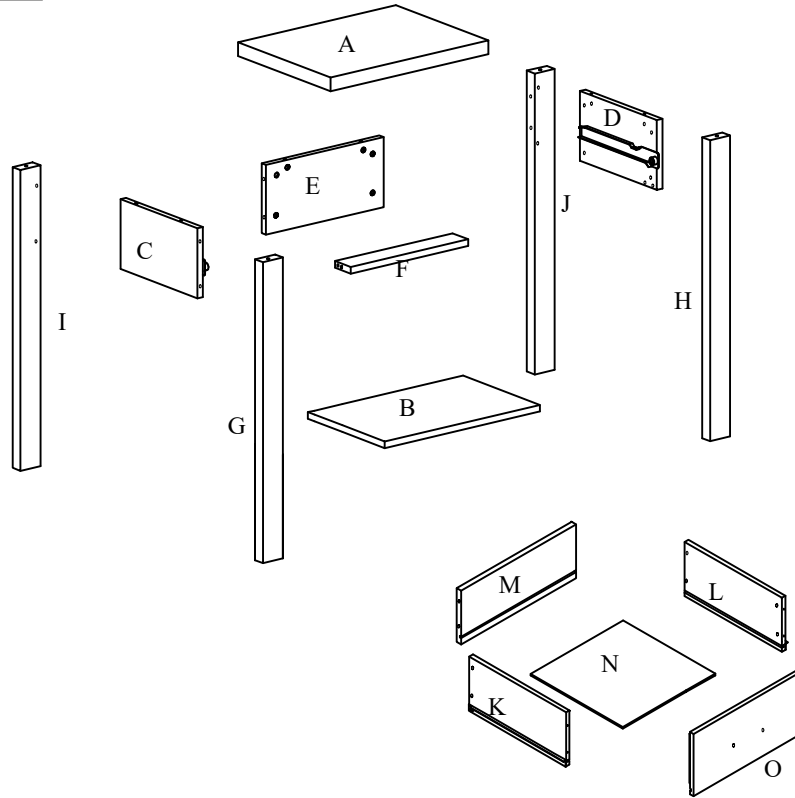

Step1:

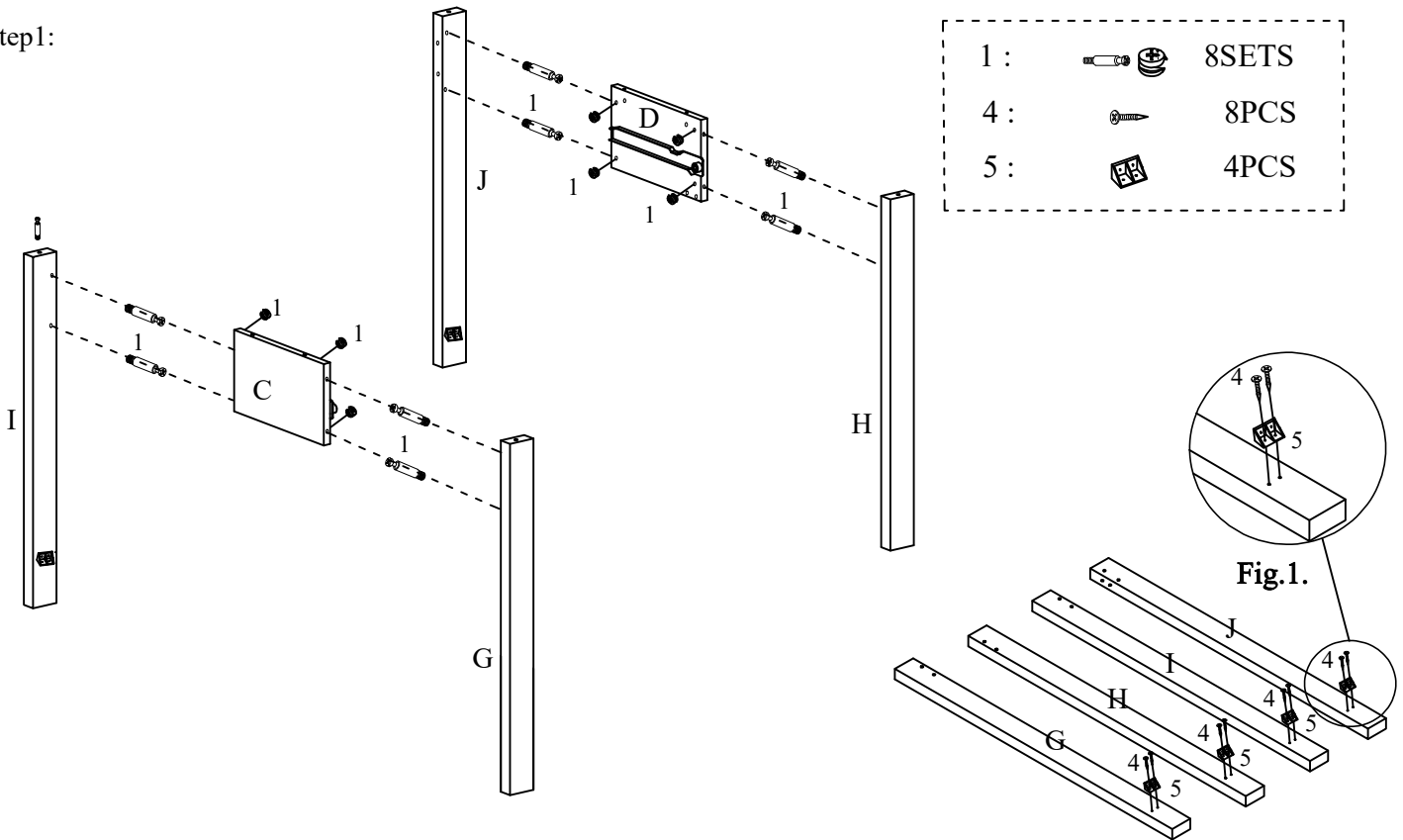

- 1). Assemble Connect Blocks (5) to Legs (G&H&I&J) using Screws (4), refer t o Fig.1.
- 2). Assemble Legs (G&H&I&J) to Side Panels (C&D) using Cam-Locks (1) as shown above.

Step2:

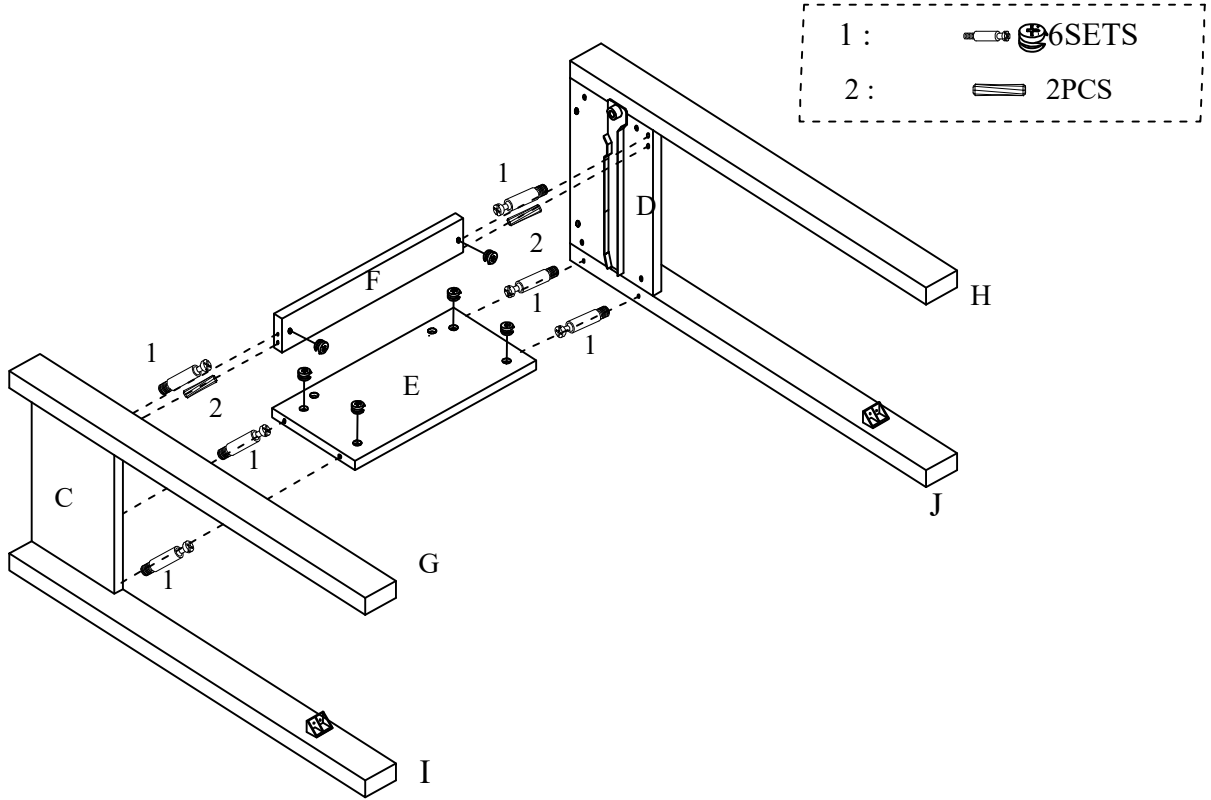

Assemble Connect Bar (F) to Side Panels (C&D) using Cam-Locks (1) and Wood Dowels (2) as shown above.
 Assemble Back Panel (E) to Rear Legs (I&J) using Cam-Locks (1) as shown above.

Step3:

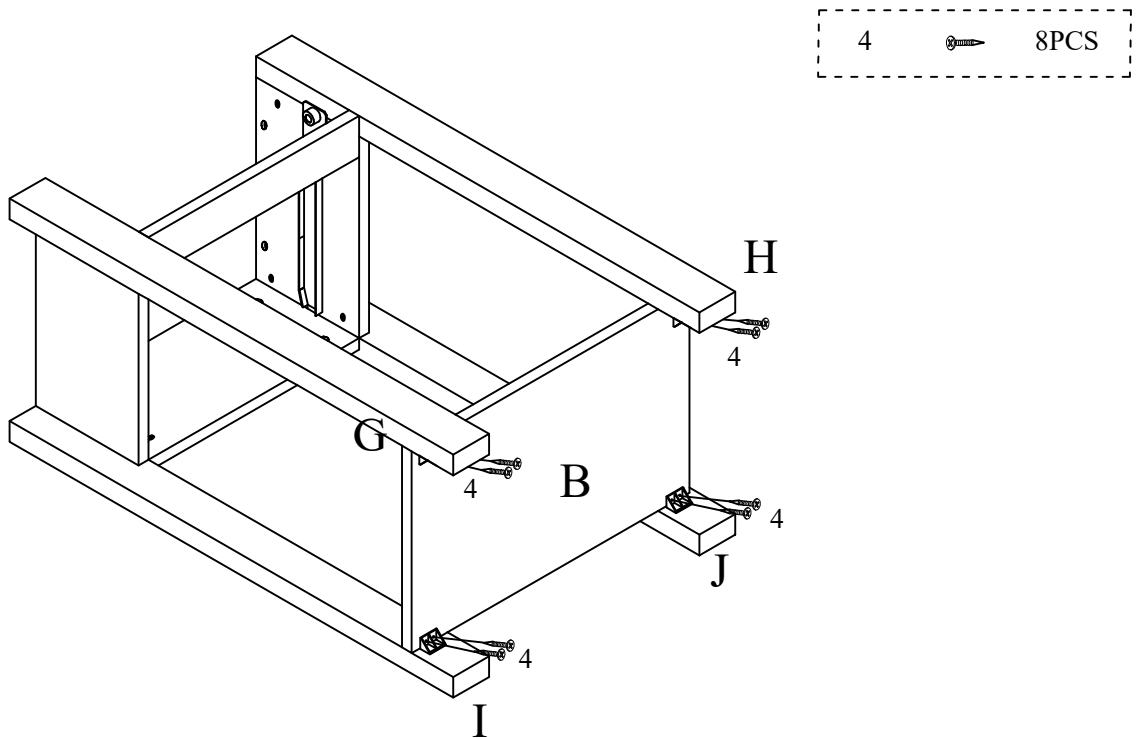

Then assemble Bottom Panel (B) to Legs (G&H&I&J) using Screws(4) as shown above.

Step4:

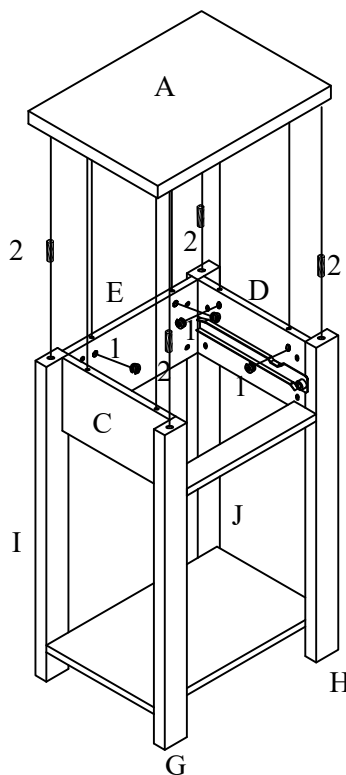
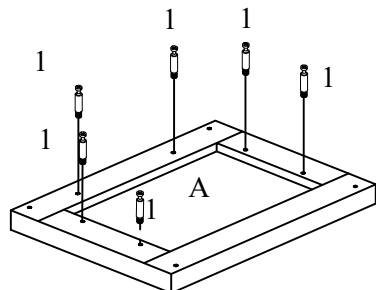

- | | | |
|----|--|-------|
| 1: | | 6sets |
| 2: | | 4pcs |

Assemble Top Panel (A) to Legs (G&H) and Side Panels (C&D), Back Panel(E) using Wood Dowels (2) and Cam-Locks (1) as shown above.

Step5:

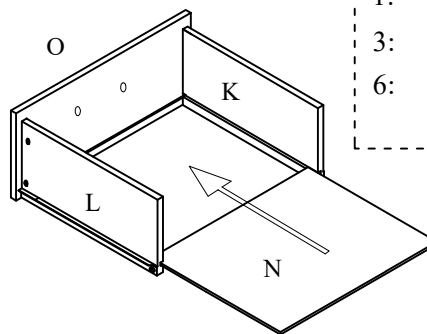
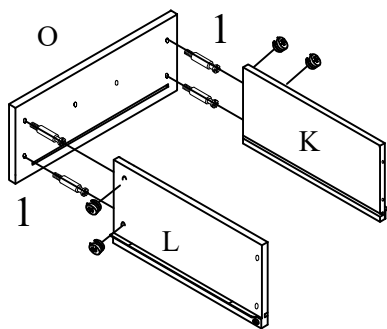

- | | | |
|----|--|-------|
| 1: | | 4sets |
| 3: | | 4pcs |
| 6: | | 1set |

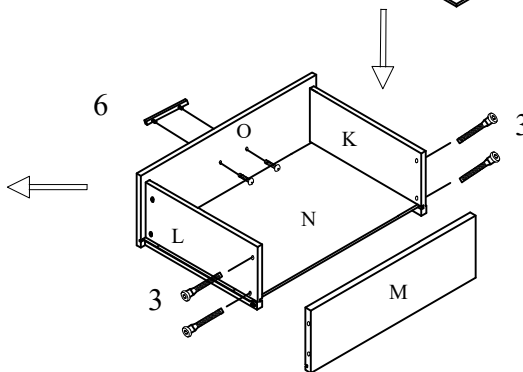
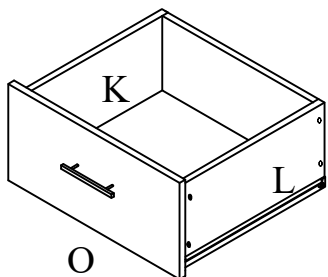

- 1). Assemble Drawer Side Panels (K&L) to Drawer Front Panel (O) using Cam-Locks(1).
- 2). Insert Drawer Bottom Panel (N) into the grooves on Drawer Side Panels (K&L) and Front Panel (O).
- 3). Attach Drawer Back Panel (M) to Drawer Side Panels (K&L) using Bolts (3).
- 4). Attach Drawer Handle (6) to Drawer Front Panel (O) using Included bolts.

Step6:

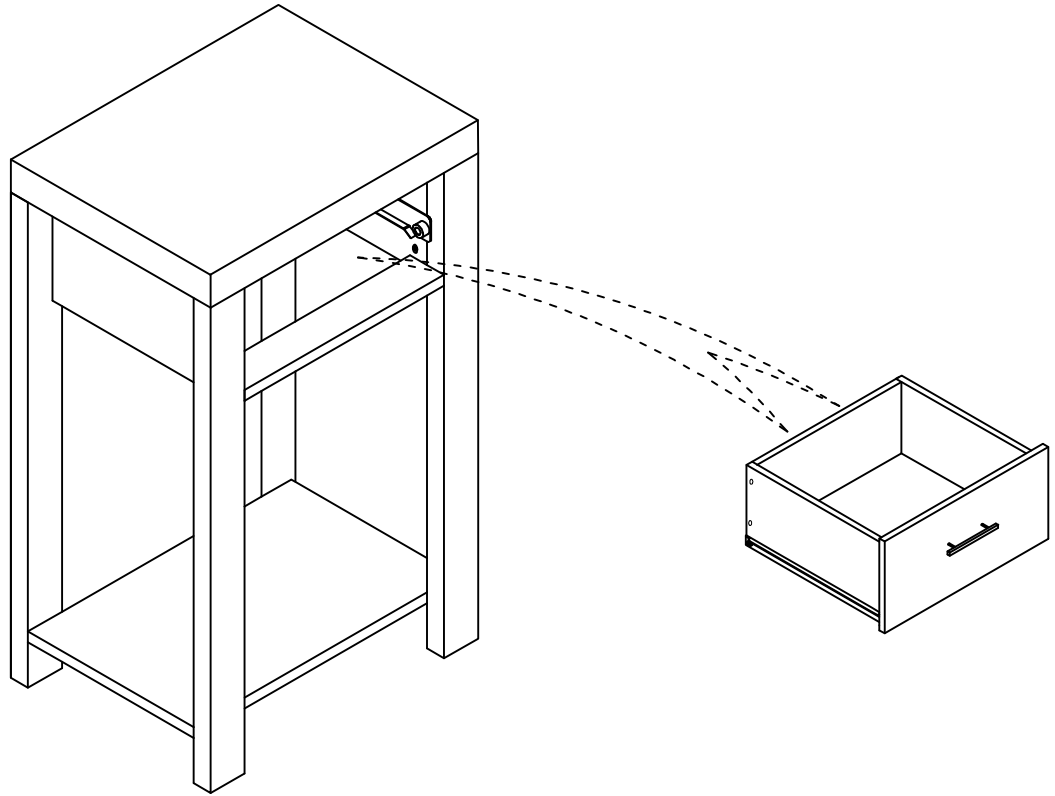

Insert Drawer into the side table as shown above.

