

# ASSEMBLY INSTRUCTIONS

Style # WR1147 -BL&WR1147-WH Wine Cabinet

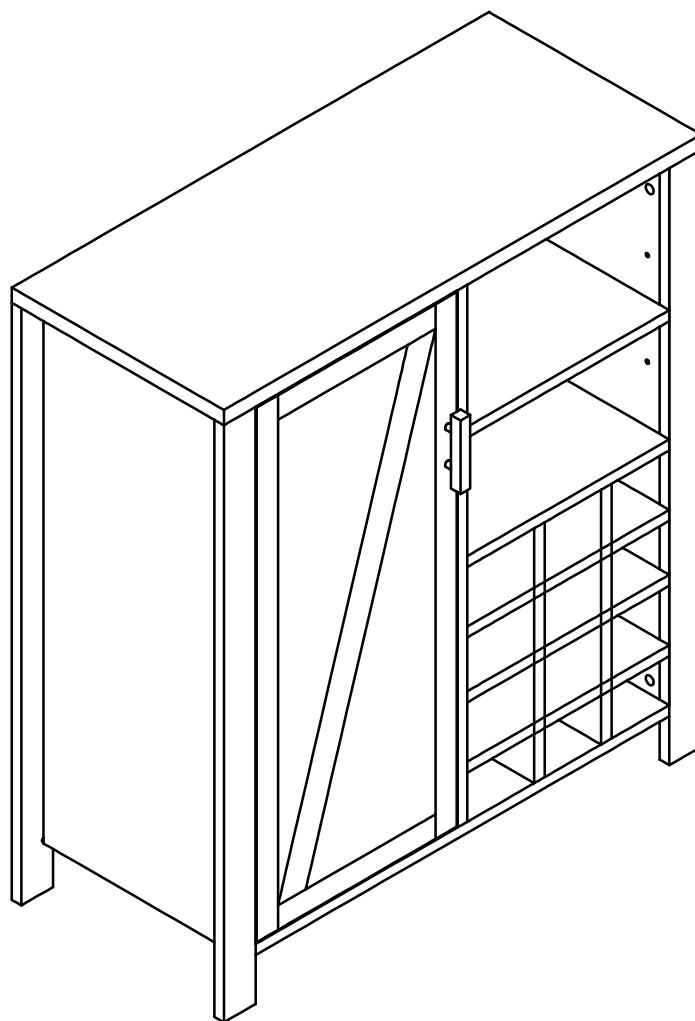

## NOTE TO CUSTOMERS:

- For ease and speed of assembly we recommend that before you commence each step of the assembly that you identify all the parts required to complete that step.
- We recommend that where possible you allow sufficient space to assemble the item as close as possible to the place where it will be once assembled.
- For the protection of your furniture we recommend that the product is placed on protected surfaces during assembly to prevent any damage.
- During assembly do not over tighten, as this may damage the product.
- Please ensure you retain all the product packaging until the item completely assembled.
- Please periodically check all fittings and re-tighten as necessary.
- It is recommended that this item should be assembled by two adults.

## To insert a cam lock: (Please read below instructions before assembling)



	<p>Diagram A</p>	<p>1. Insert cam screw into hole as shown in diagram A .</p>
	<p>Diagram B</p>	<p>Make sure not to insert the cam screw: Too deep as shown in figure B as this will cause the cam screw to be misaligned and unable to interlock properly.</p>
	<p>Diagram C</p>	<p>Also avoid inserting the cam screw too close to the surface of the hole as shown in figure C, as this will cause the cam lock to be too loose, and not interlock properly.</p>

	<p>2. Connect the panels together.</p>
	<p>3. When inserting the cam lock make sure the arrow of the cam lock faces the cam screw.</p>
	<p>4. To tighten the cam lock turn the cam lock clockwise 90-180 degree or until the arrow is facing opposite the place cam lock was inserted.</p>
<p><b>NOTE: DO NOT USE AN AUTOMATIC SCREWDRIVER TO TIGHTEN CAM LOCKS.</b></p>	

### Note:

- Read these instructions carefully before assembling.
- Tools required : Phillips screwdriver, flat screwdriver.
- Find a clean, smooth area on which to work , such as a carpet, in order to avoid scratching the wood surfaces.
- Wait to dispose of the packing material until assembly is complete and all parts and hardware are accounted for.
- Two or more people might be required for assembly.

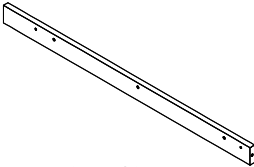
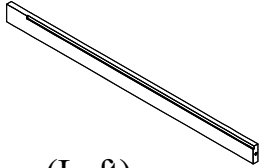

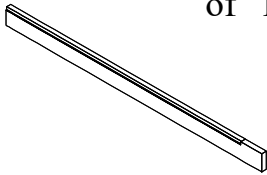
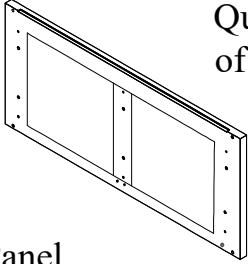
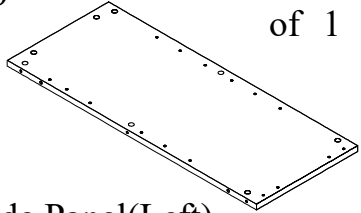
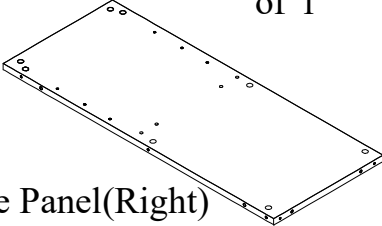
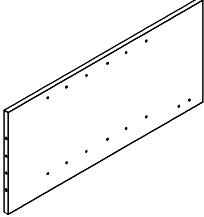
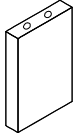
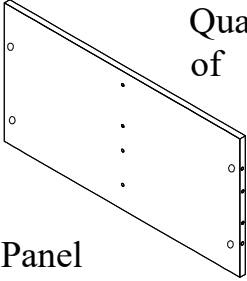
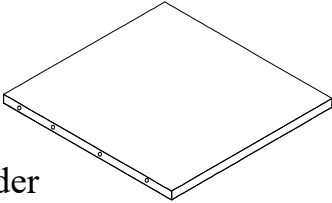
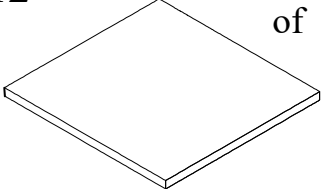
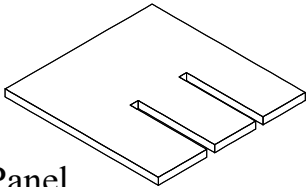
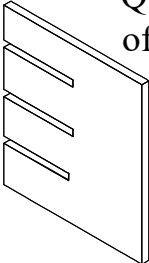
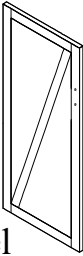
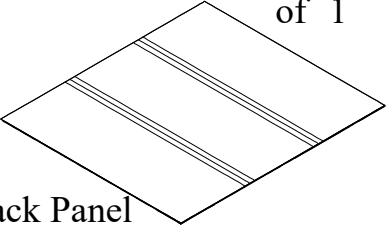
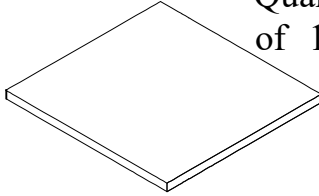

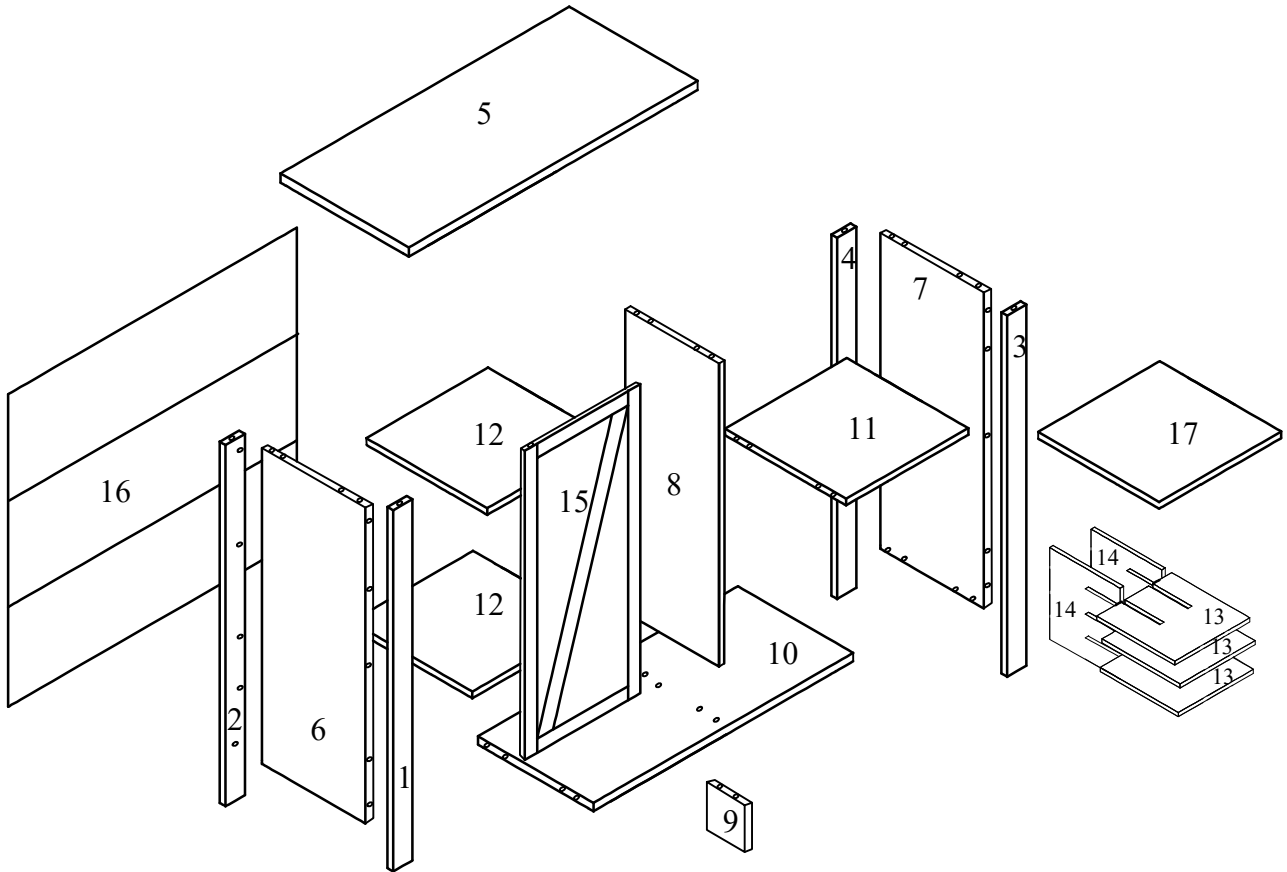

# Part List

<p>1</p> <p style="text-align: right;">Quantity of 1</p>  <p>Front Leg(Left)</p>	<p>2</p> <p style="text-align: right;">Quantity of 1</p>  <p>Rear Leg(Left)</p>	<p>3</p> <p style="text-align: right;">Quantity of 1</p>  <p>Front Leg(Right)</p>
<p>4</p> <p style="text-align: right;">Quantity of 1</p>  <p>Rear Leg(Right)</p>	<p>5</p> <p style="text-align: right;">Quantity of 1</p>  <p>Top Panel</p>	<p>6</p> <p style="text-align: right;">Quantity of 1</p>  <p>Side Panel(Left)</p>
<p>7</p> <p style="text-align: right;">Quantity of 1</p>  <p>Side Panel(Right)</p>	<p>8</p> <p style="text-align: right;">Quantity of 1</p>  <p>Divider</p>	<p>9</p> <p style="text-align: right;">Quantity of 1</p>  <p>Support Leg</p>
<p>10</p> <p style="text-align: right;">Quantity of 1</p>  <p>Bottom Panel</p>	<p>11</p> <p style="text-align: right;">Quantity of 1</p>  <p>Divider</p>	<p>12</p> <p style="text-align: right;">Quantity of 2</p>  <p>Left Shelf Panel</p>
<p>13</p> <p style="text-align: right;">Quantity of 3</p>  <p>Cross Panel</p>	<p>14</p> <p style="text-align: right;">Quantity of 2</p>  <p>Cross Panel</p>	<p>15</p> <p style="text-align: right;">Quantity of 1</p>  <p>Door Panel</p>
<p>16</p> <p style="text-align: right;">Quantity of 1</p>  <p>Back Panel</p>	<p>17</p> <p style="text-align: right;">Quantity of 1</p>  <p>Right Shelf Panel</p>	

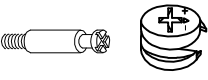

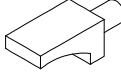
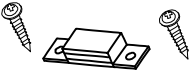
# Part List

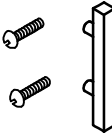
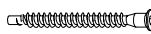
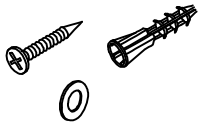

# Hardware List

<p>A</p> <p style="text-align: right;">Quantity of 26</p>  <p><b>Camlock</b></p>	<p>B</p> <p style="text-align: right;">Quantity of 28</p>  <p><b>Wood Dowel</b></p>	<p>C</p> <p style="text-align: right;">Quantity of 21</p>  <p><b>Screw</b></p>	<p>D</p> <p style="text-align: right;">Quantity of 12</p>  <p><b>Shelf Supporter</b></p>
<p>E</p> <p style="text-align: right;">Quantity of 1</p>  <p><b>Magnet with Screw</b></p>	<p>F</p> <p style="text-align: right;">Quantity of 2</p>  <p><b>Door Pin</b></p>	<p>G</p> <p style="text-align: right;">Quantity of 1</p>  <p><b>Handle with Bolt</b></p>	<p>H</p> <p style="text-align: right;">Quantity of 4</p>  <p><b>Bolt</b></p>
<p>I</p> <p style="text-align: right;">Quantity of 1</p>  <p><b>Anchor with Screw</b></p>	<p>J</p> <p style="text-align: right;">Quantity of 1</p>  <p><b>Anti-tip kit</b></p>	<p style="text-align: right;">Quantity of 1</p>  <p><b>Allen Wrench</b></p>	



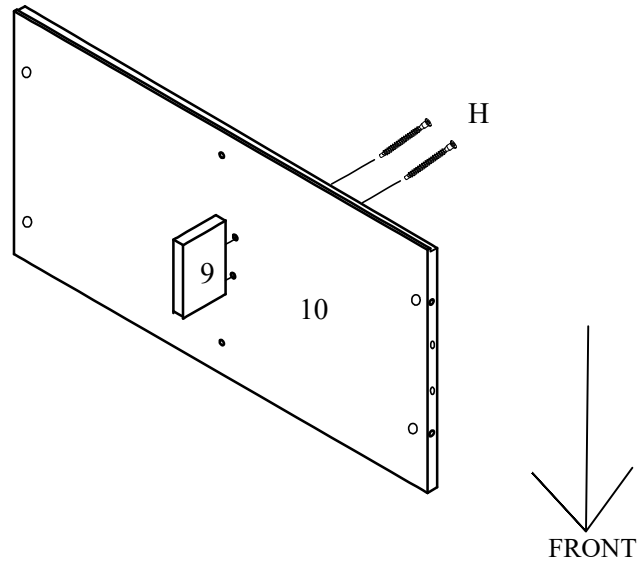

# Step 1:

H :		2PCS
		



Assemble Support Leg (9) to Bottom Panel (10) using Bolts (H) as shown above.

# Step 2:

B :		2PCS
H :		2PCS
E :		1SET
		

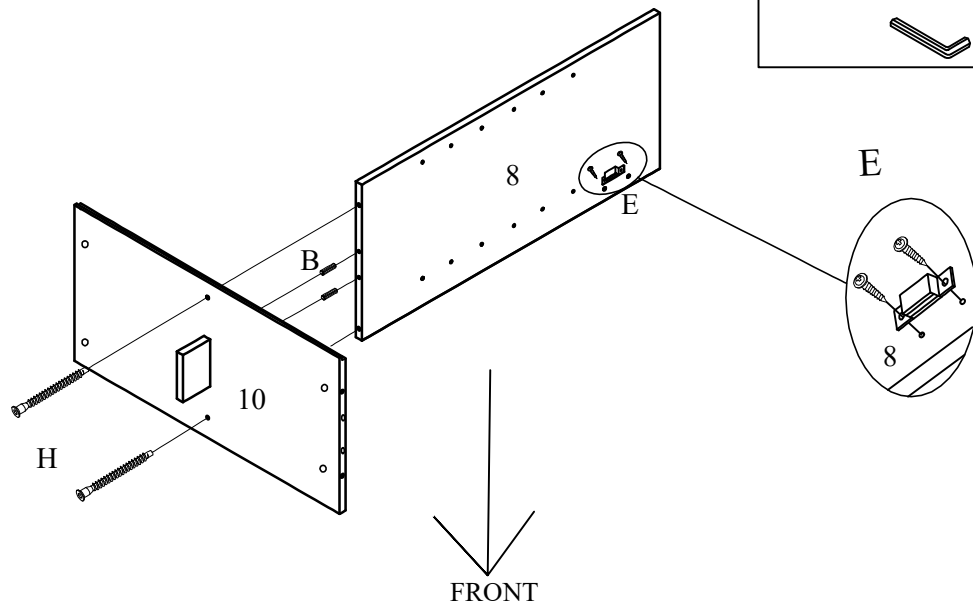

Attach Magnet (E) to the Divider (8) using included Screws.  
Assemble Divider (8) to Bottom Panel (10) using Bolts (H) and Wood Dowels (B) as shown above.

### Step 3:

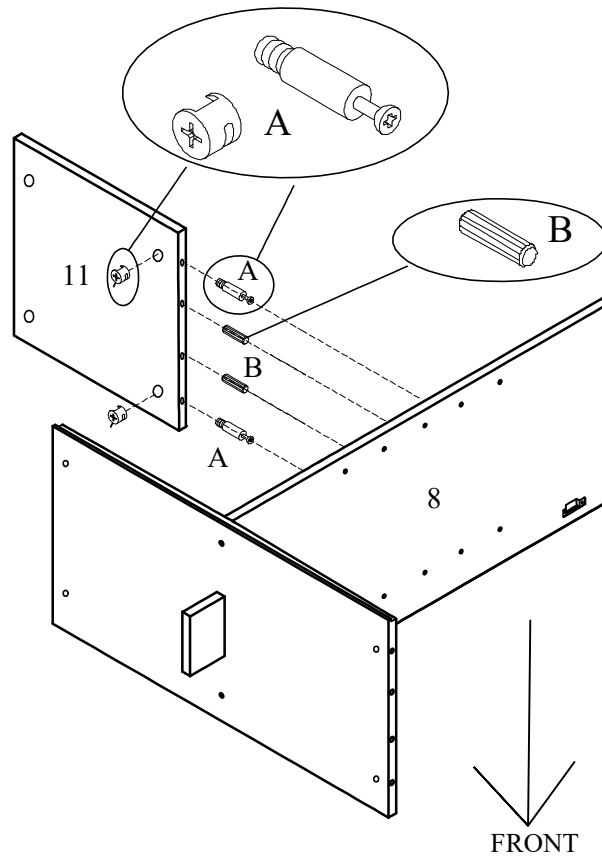

Assemble Divider (11) to Divider (8) using Cam-Locks (A) and Wood Dowels (B) as shown above.

### Step 4:

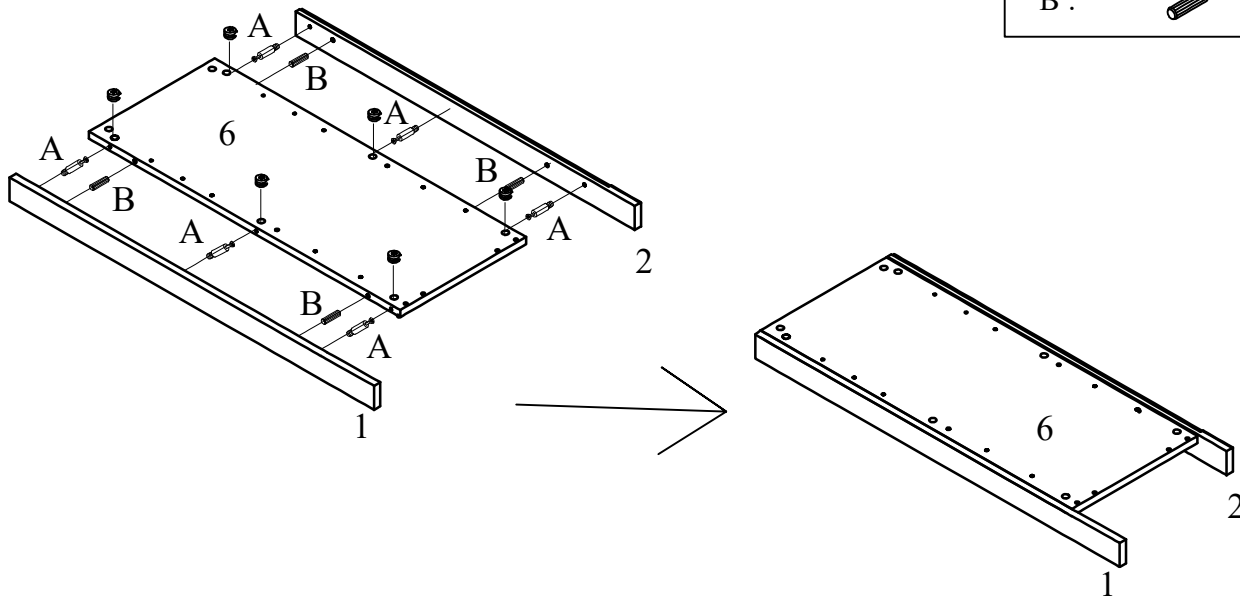

Assemble Legs (1 & 2) to Side Panels 6 using Cam-Locks (A) and Wood Dowels (B) as shown above.

## Step 5:

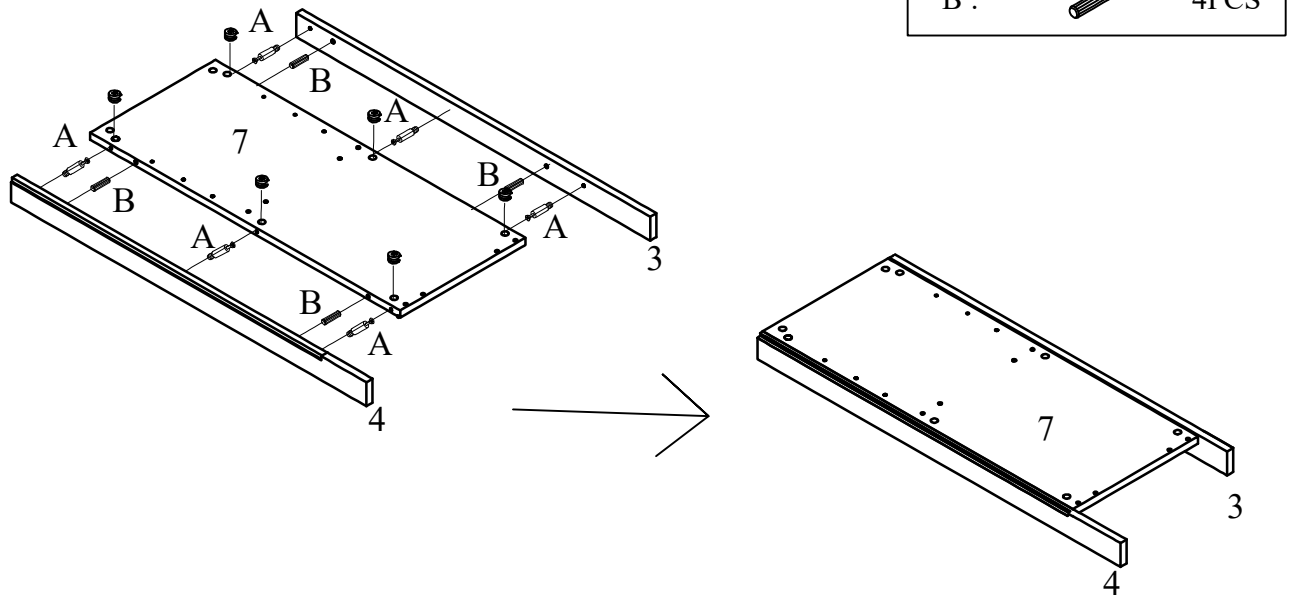

Assemble Legs (3 & 4) to Side Panels (7) using Cam-Locks (A) and Wood Dowels (B) as shown above.

## Step 6:

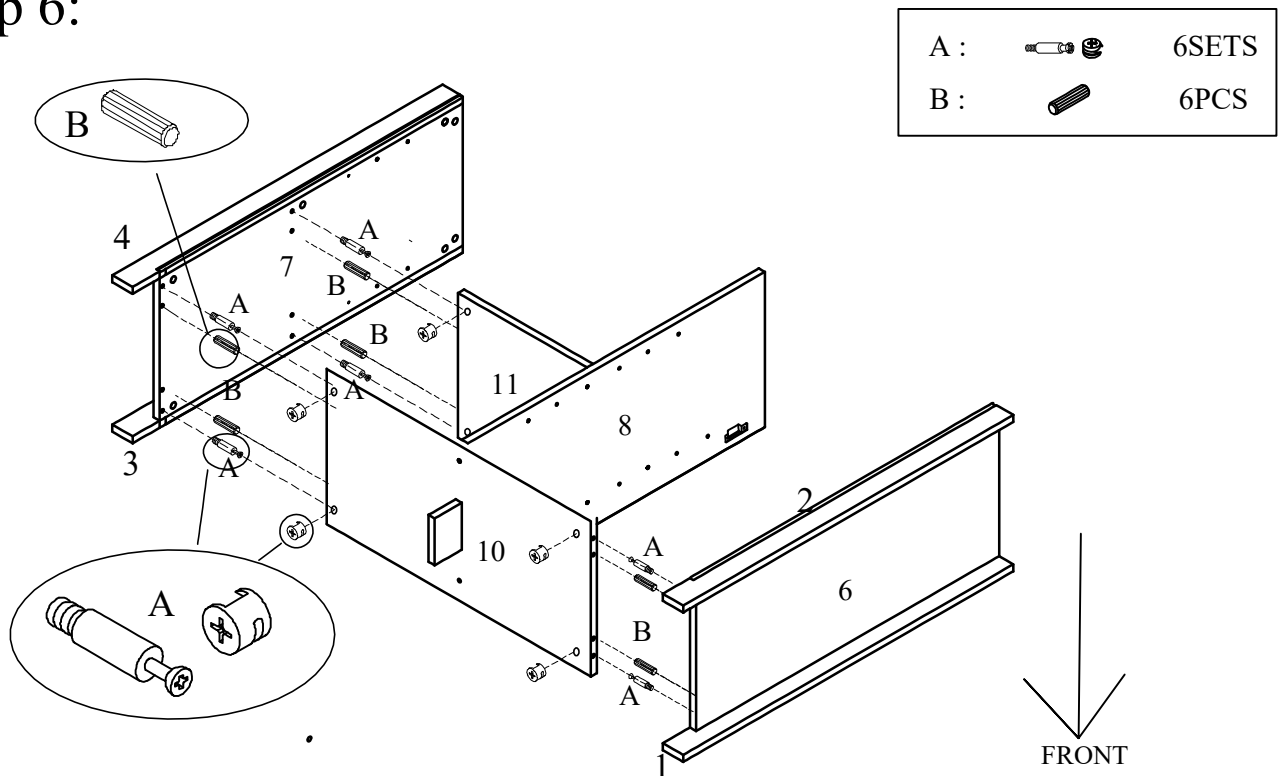

Assemble Side Panels (6 & 7) to Bottom Panel (10) and Divider (11) using Cam-Locks (A) and Wood Dowels (B) as shown above.

## Step 7:

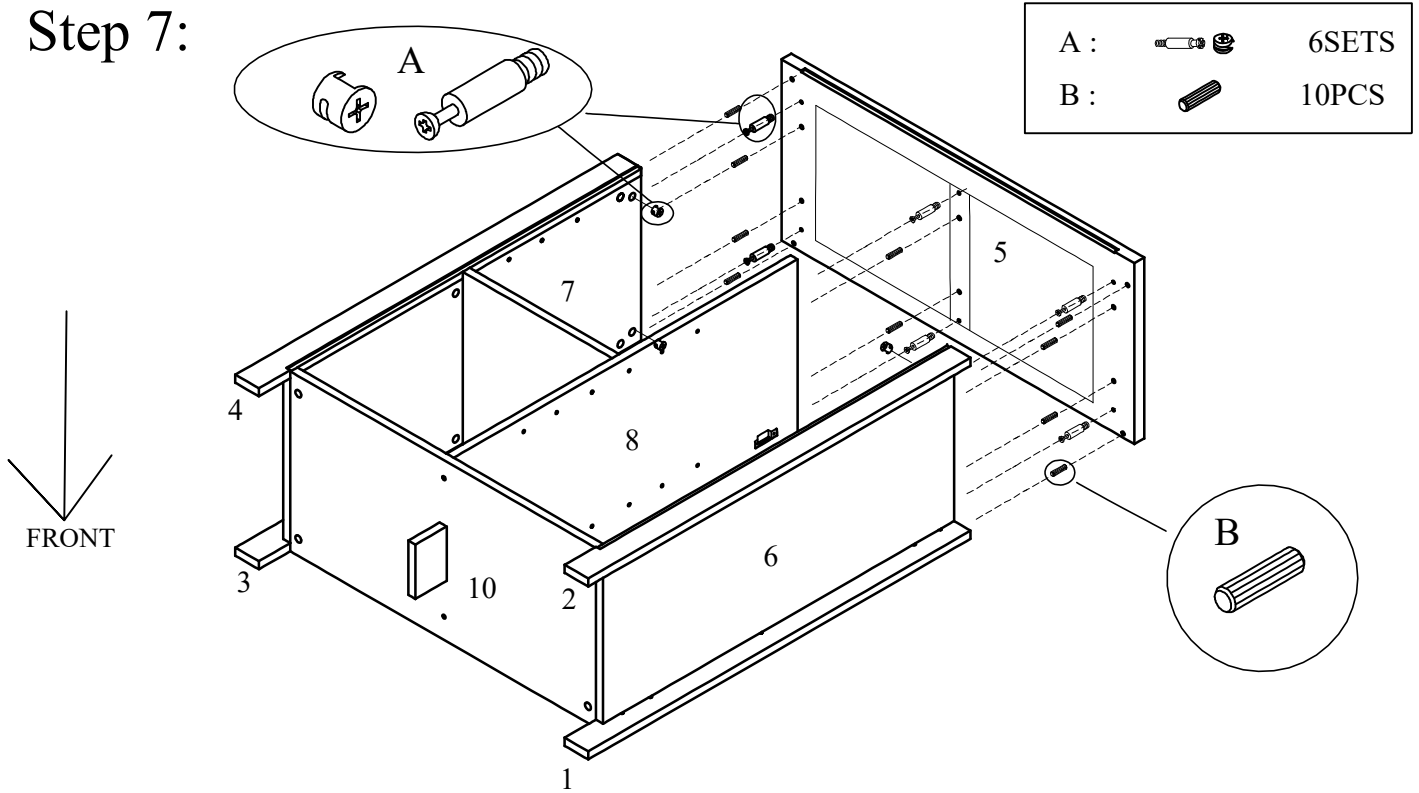

Assemble Top Panel (5) to Side Panels (6 & 7), Divider (8) and Legs (1 & 2 & 3 & 4) using Cam-Locks (A) and Wood Dowels (B) as shown above.

## Step 8:

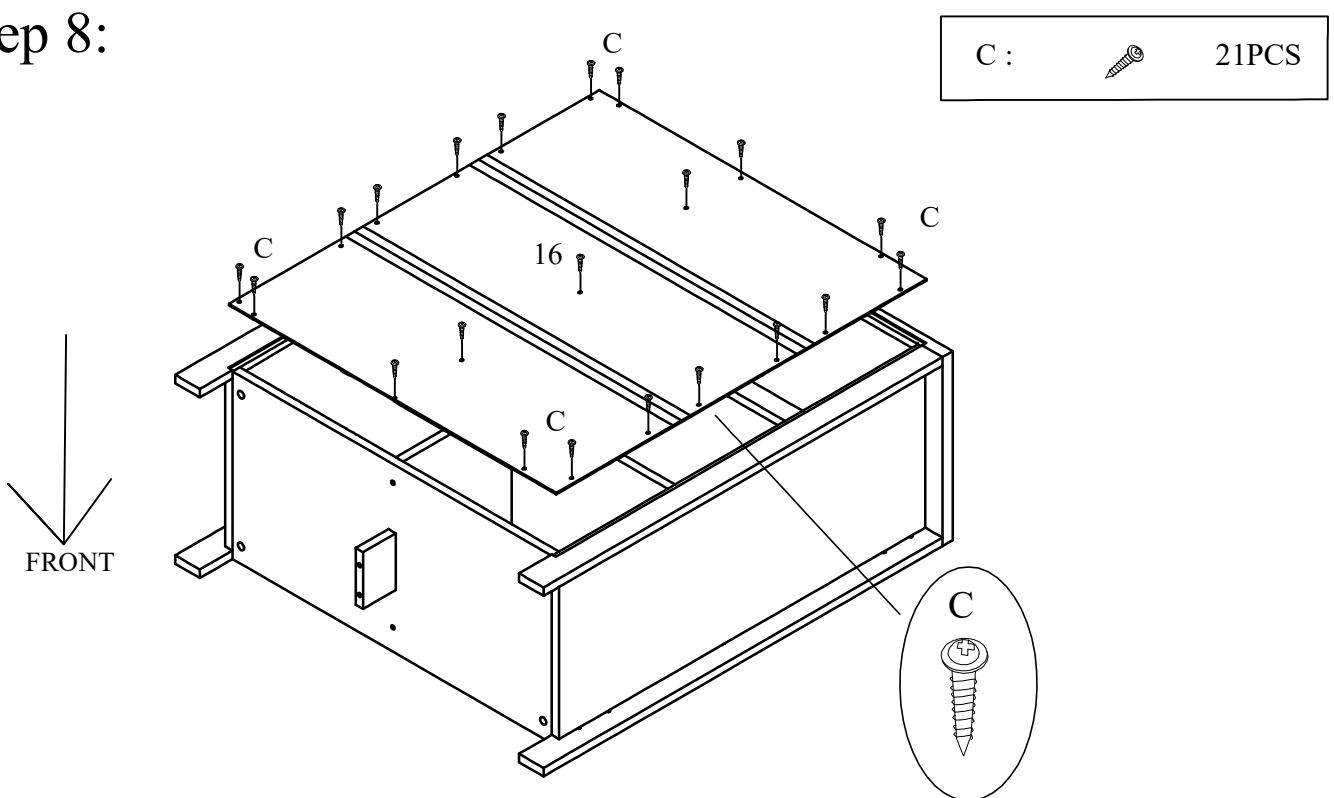

Assemble Back Panel (16) to the back of this unit using Screws (C) as shown above.



## Step 9:

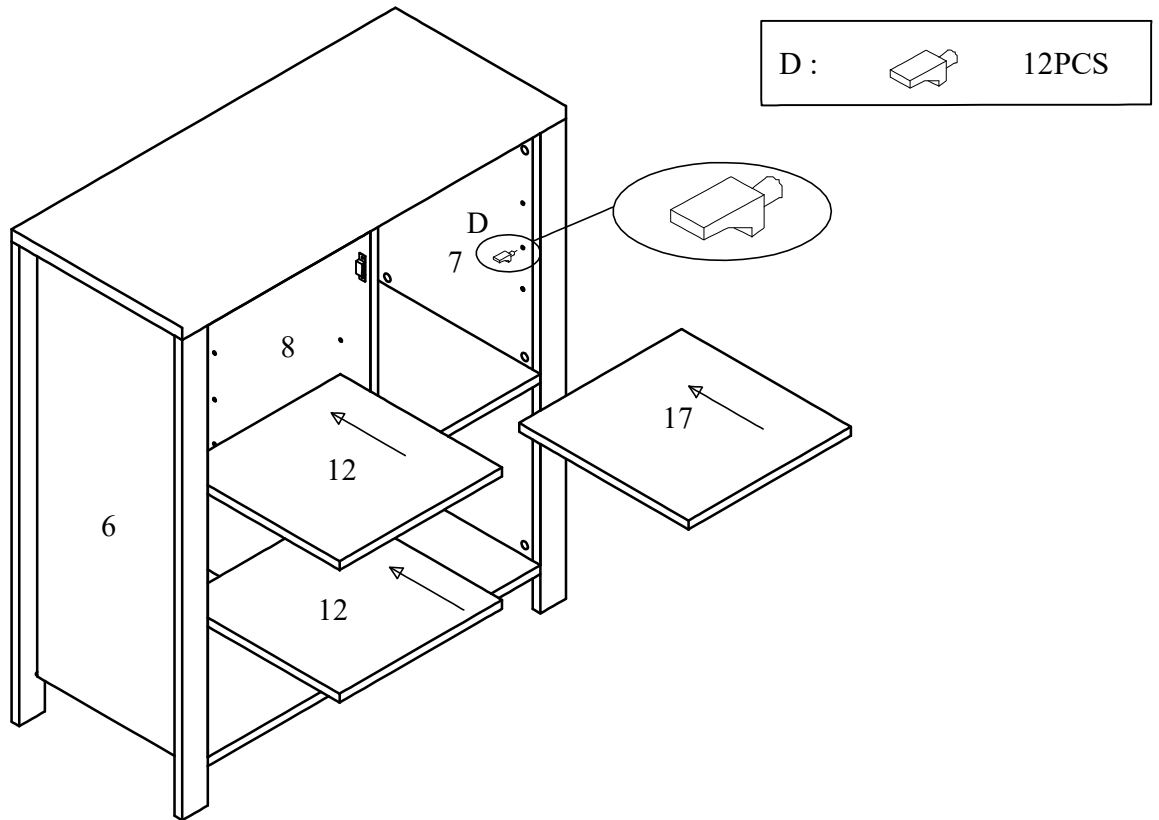

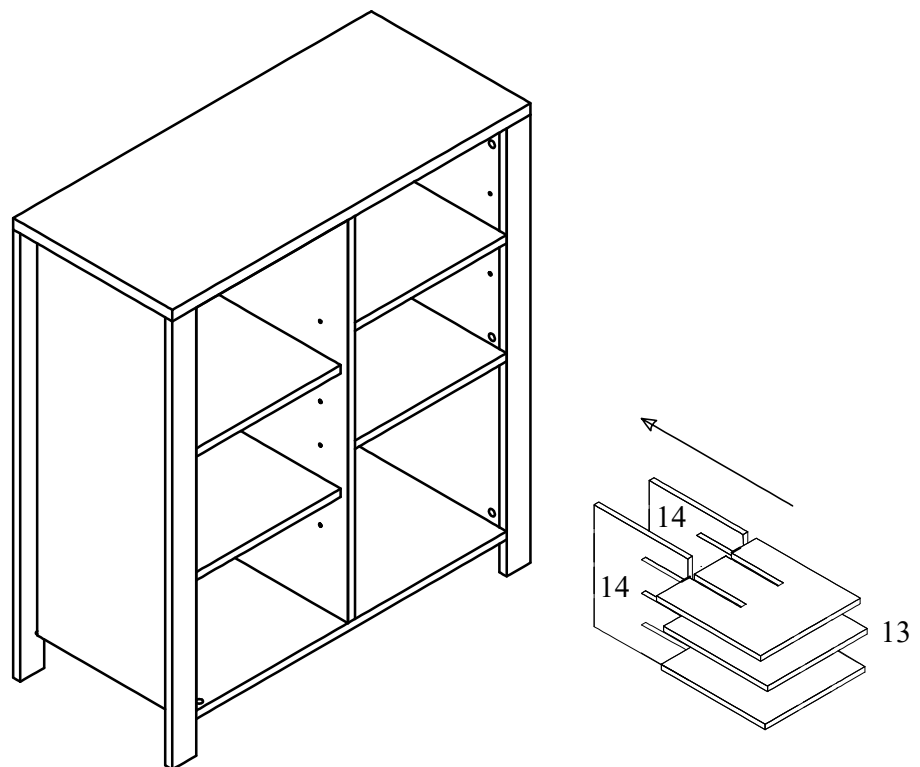

Insert Shelf Supporters (D) into the holes of the Side Panels (6 & 7) and Divider (8), then put the Shelf Panels (12 & 17) onto the Shelf Supporters (D).

## Step 10:



Attach Cross Panels (13) to Cross Panels (14) as above drawing shown, then insert it into the open space.

## Step 11:

G :		1SETS
F :		2PCS

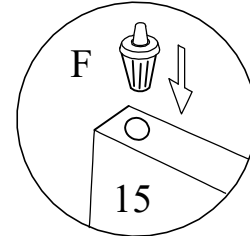
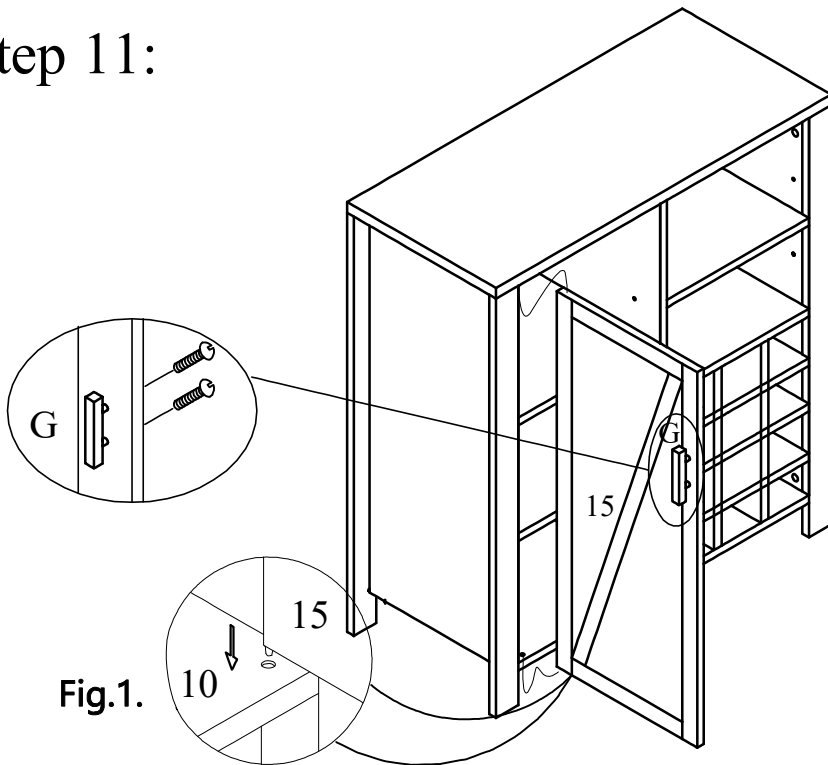
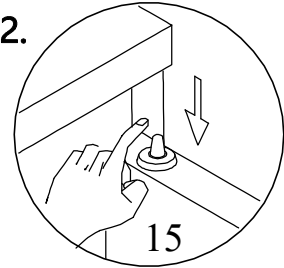



Fig.2.



Insert Door Pins (F) into the hole on the two ends of Door Panel (15), Then attach Door Handle (G) to Door Panel (15) using included bolts.

Connect Door Panel (15) to Bottom Panel (10), refer to Fig.1. Then press down Door Pin (F) ( see Fig.2.) and hold the Door Panel carefully into the cabinet with the upper pin popping up into the hole of Top Panel (5).

## Step 12:

I :		1SET
J :		1SET

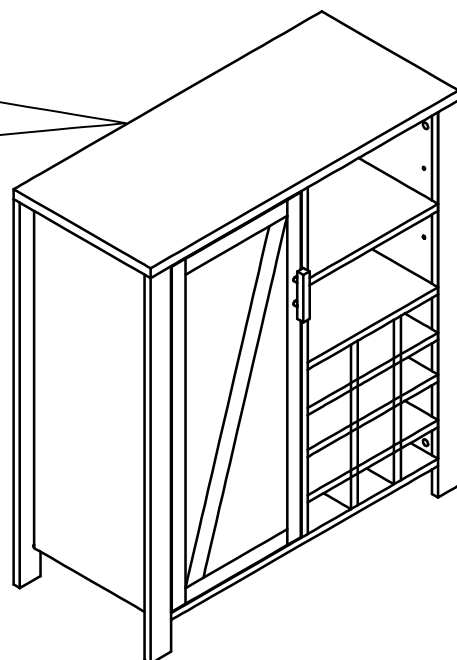
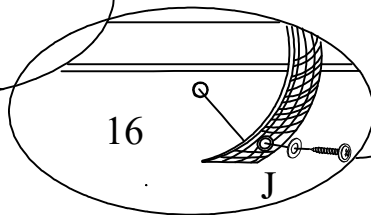
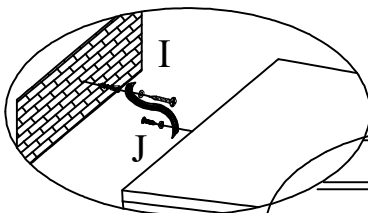

Attach Anti-tip Kit (J) nylon strap to the Back Panel (16), then attach the other end of the nylon strap to the wall using Anchor and Screw (I) as shown above.