

ASSEMBLY INSTRUCTIONS

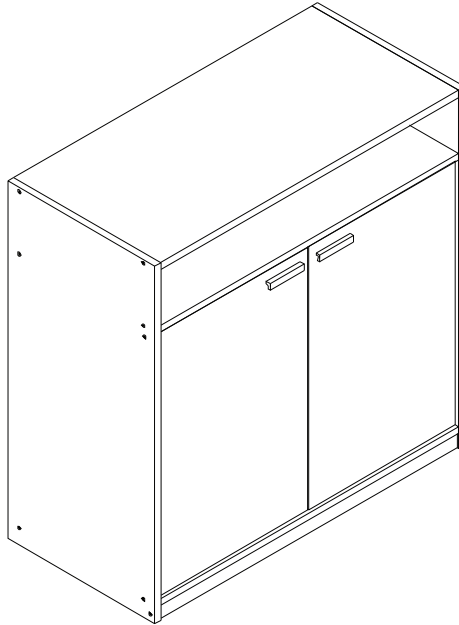



MODEL : #SR6551 SHOE CABINET





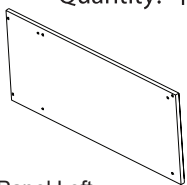
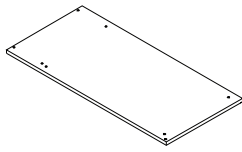
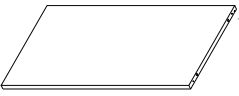

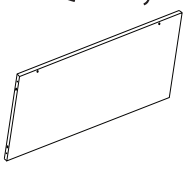
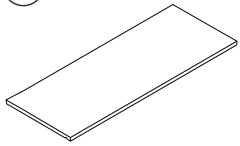

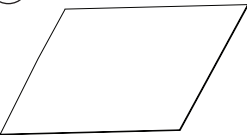
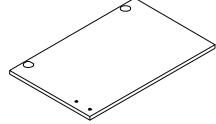
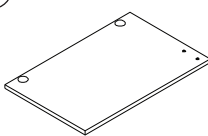

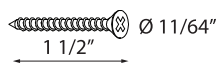
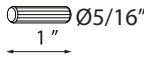

NOTE TO CUSTOMERS:

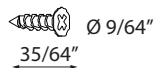
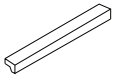
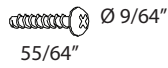
- For ease and speed of assembly we recommend that before you commence each step of the assembly that you identify all the parts required to complete that step.
- We recommend that where possible you allow sufficient space to assemble the item as close as possible to the place where it will be once assembled.
- For the protection of your furniture we recommend that the product is placed on a dry, soft, smooth and clean surfaces during assembly to prevent any damage. Avoid damp and direct sunlight.
- During assembly do not over tighten the screws or bolts, as this may damage the product.
- Please ensure you retain all the product packaging until the item is completely assembled.
- Periodically check all fitting and re-tighten as necessary.
- Never allow any liquids to remain on your furniture as absorption can cause the wood to warp or finish to de-laminate.
- It is recommended that this item should be assembled by two adults.

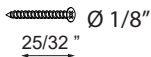
PARTS IDENTIFICATION

<p>① Quantity: 1</p>  <p>Side Panel Left</p>	<p>② Quantity: 1</p>  <p>Side Panel Right</p>	<p>③ Quantity: 1</p>  <p>Top Panel</p>	<p>④ Quantity: 1</p>  <p>Upper Shelf Panel</p>	<p>⑤ Quantity: 1</p>  <p>Base Panel</p>
<p>⑥ Quantity: 2</p>  <p>Adjustable Shelf Panel</p>	<p>⑦ Quantity: 2</p>  <p>Apron/Skirt Rail</p>	<p>⑧ Quantity: 1</p>  <p>Small Back Panel</p>	<p>⑨ Quantity: 1</p>  <p>Large Back Panel</p>	<p>⑩ Quantity: 1</p>  <p>Left Door</p>
<p>⑪ Quantity: 1</p>  <p>Right Door</p>				

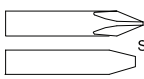
HARDWARE LIST

<p>Ⓐ Screw #9 x 1 1/2"</p>  <p>Quantity: 16 pcs</p>	<p>Ⓑ Wooden Dowel M8 x 25</p>  <p>Quantity: 16 pcs</p>	<p>Ⓒ Hinges</p>  <p>Quantity: 4 pcs</p>	<p>Ⓓ Hinge's Screw M3.5 x 14</p>  <p>Quantity: 16 pcs</p>	<p>Ⓔ Door Pull</p>  <p>Quantity: 2 pcs</p>
<p>Ⓕ Pan head Screw #6 x 22</p>  <p>Quantity: 4 pcs</p>	<p>Ⓖ Corner Wedge</p>  <p>Quantity: 6 pcs</p>	<p>Ⓗ Corner Wedge Screw m3 x 20mm</p>  <p>Quantity: 6 pcs</p>	<p>Ⓖ Shelf Support Pin</p>  <p>Quantity: 8 pcs</p>	<p>Ⓙ Leg Stud</p>  <p>Quantity: 6 pcs</p>
<p>Ⓚ Sticker</p>  <p>Quantity: 16 pcs</p>	<h3>TOOLS REQUIRED</h3>  SCREW DRIVER  MALLET			

STEP 1

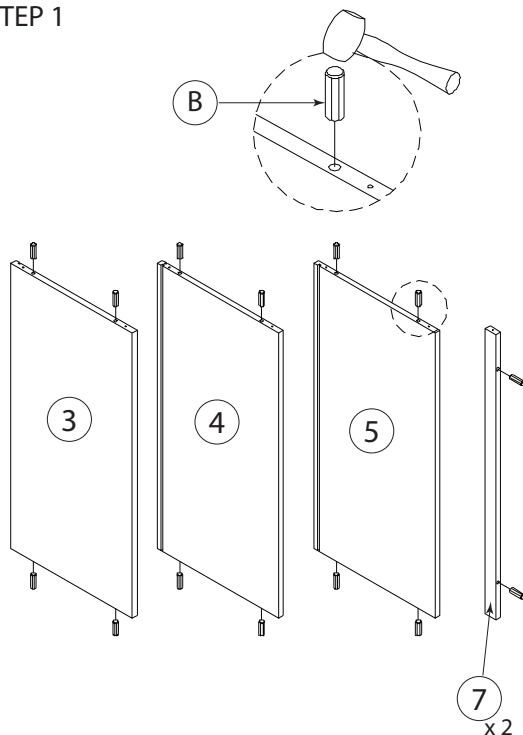

STEP 2

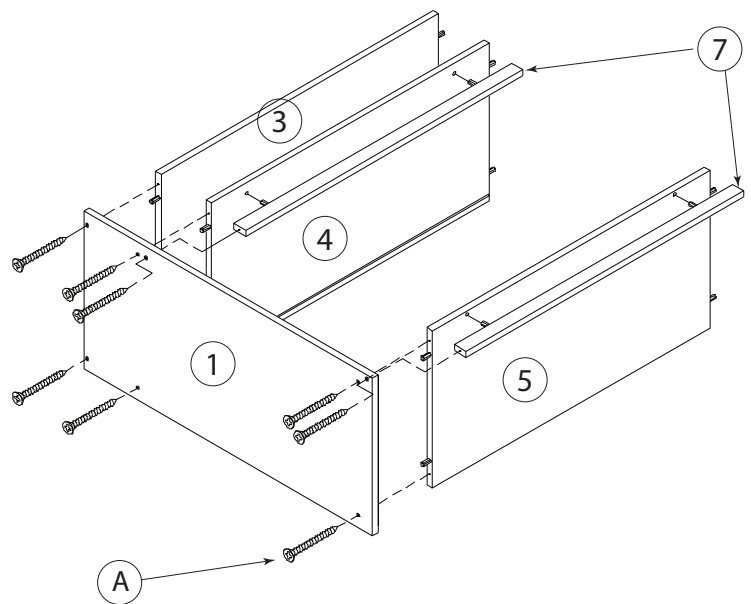

STEP 3

STEP 4

STEP 5

STEP 6

STEP 7

STEP 8

Guidelines of fixing the hinges

A-Lateral adjustment
by adjusting the
screws in hinges arm.

B-Vertical adjustment
by adjusting the screws
in hinges arm.

C-Front to back
by adjusting the sliding
hinges and tighten it.

STEP 9