

# ASSEMBLY INSTRUCTIONS

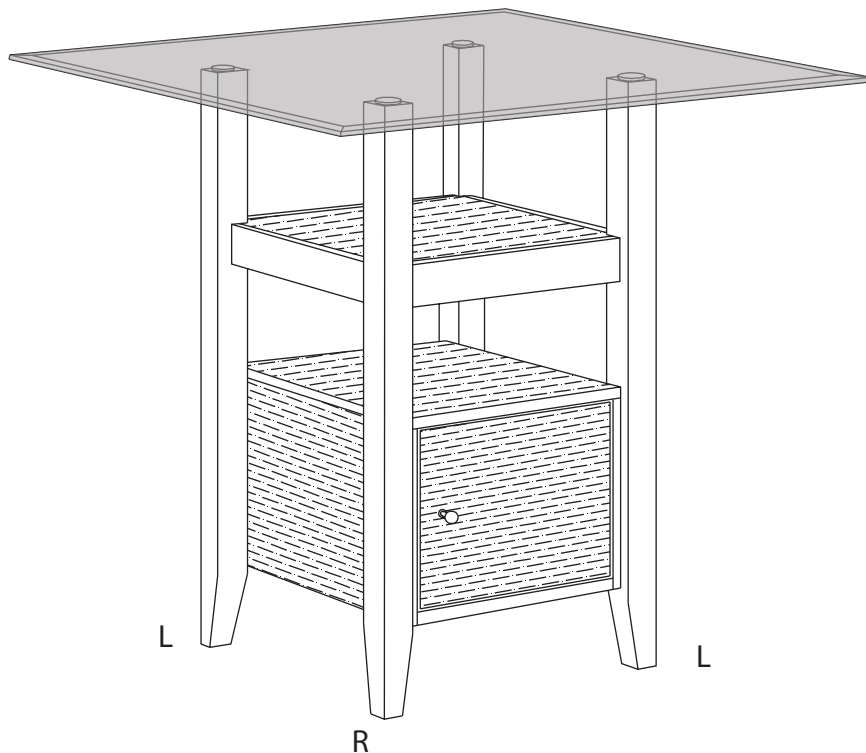

## COUNTER HEIGHT DINING TABLE







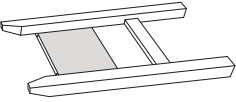
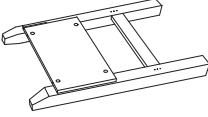
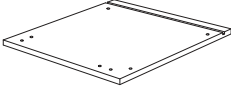
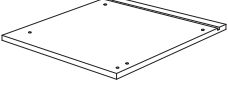

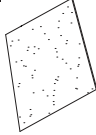
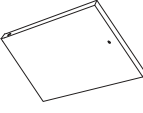

### NOTE TO CUSTOMERS:

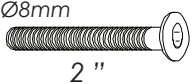
- For ease and speed of assembly we recommend that before you commence each step of the assembly that you identify all the parts required to complete that step.
- We recommend that where possible you allow sufficient space to assemble the item as close as possible to the place where it will be once assembled.
- For the protection of your furniture we recommend that the product is placed on a dry, soft, smooth and clean surfaces during assembly to prevent any damage. Avoid damp and direct sunlight.
- During assembly do not over tighten the screws or bolts, as this may damage the product.
- Please ensure you retain all the product packaging until the item is completely assembled.
- Periodically check all fitting and re-tighten as necessary.
- Never allow any liquids to remain on your furniture as absorption can cause the wood to warp or finish to de-laminate.
- It is recommended that this item should be assembled by two adults.

## PARTS IDENTIFICATION

<b>CARTON A</b>	<b>A</b> Quantity: 1  Glass Table Top	<b>CARTON B</b>	<b>B</b> Quantity: 1  Leg Frame (Left)	<b>C</b> Quantity: 1  Leg Frame (Right)	<b>D</b> Quantity: 1  Storage Top Panel
	<b>E</b> Quantity: 1  Storage Bottom Panel		<b>F</b> Quantity: 2  Rail (Front & Rear)	<b>G</b> Quantity: 1  Back Panel	<b>H</b> Quantity: 1  Door

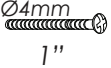
## HARDWARE LIST

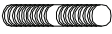
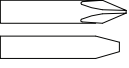
<b>1</b> Quantity: 4  JCBC Bolt m6 x 50mm	<b>2</b> Quantity: 4  Spring Washer	<b>3</b> Quantity: 1  Allen Key	<b>4</b> Quantity: 8  Connecting Bolt	<b>5</b> Quantity: 8  Camlock
<b>6</b> Quantity: 1  Door Catch	<b>7</b> Quantity: 1  Door Knob	<b>8</b> Quantity: 1  Pan Head Screw m4 x 25	<b>9</b> Quantity: 2  Pivot Hinge	<b>10</b> Quantity: 4  Alum. Disc Glass Top adapter.
<b>11</b> Quantity: 4  Bolt for Alum. Disc	<b>TOOLS REQUIRED</b>  Household screw driver			

### STEP 1 *Align connecting bolts*

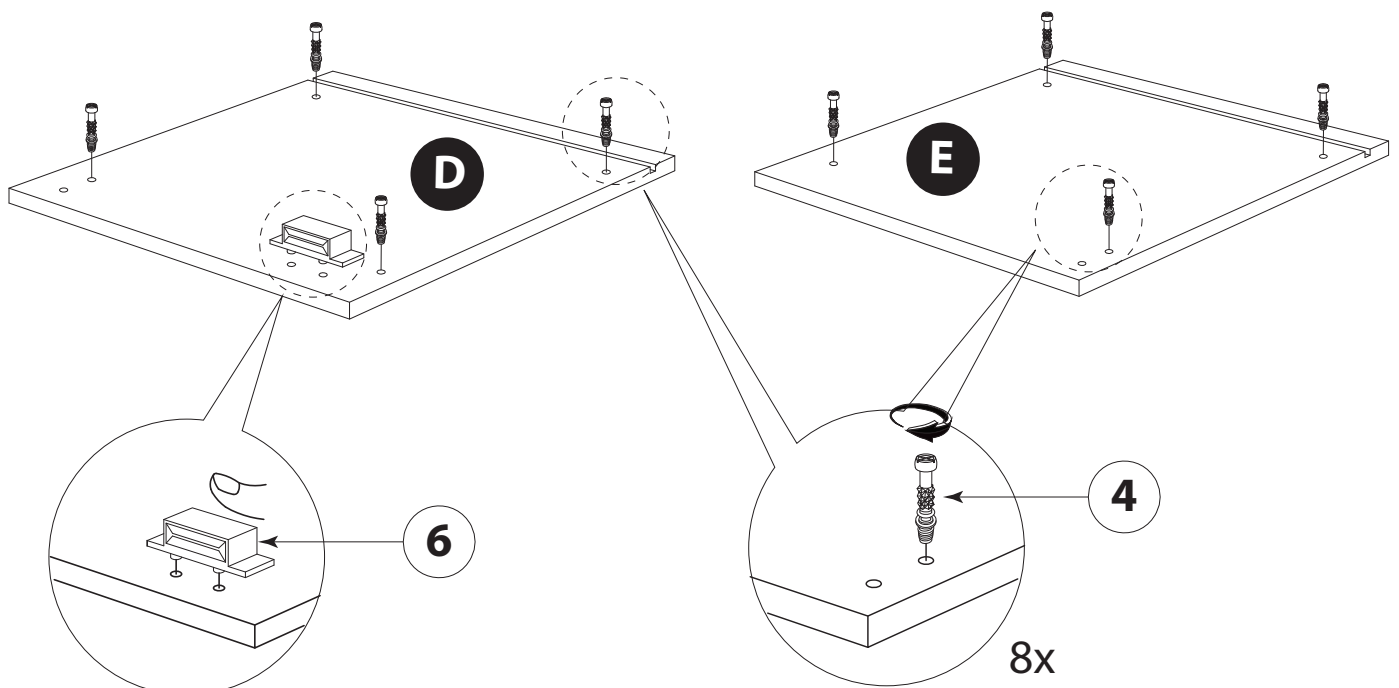

## STEP 2

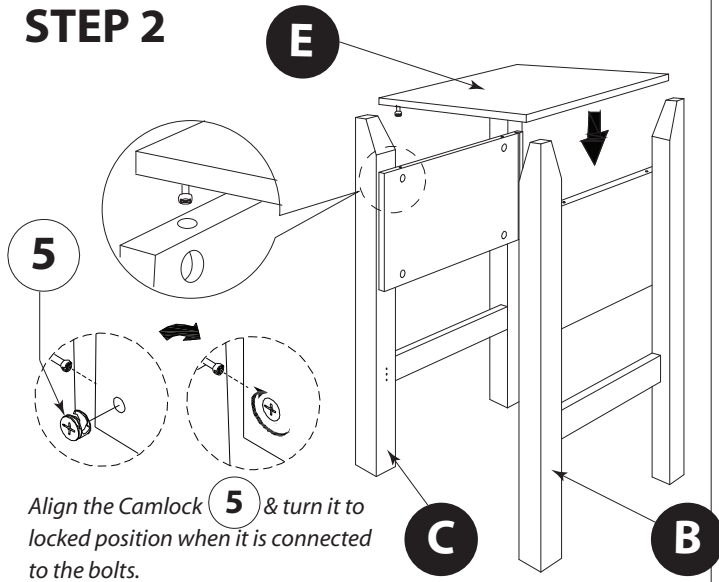

## STEP 3

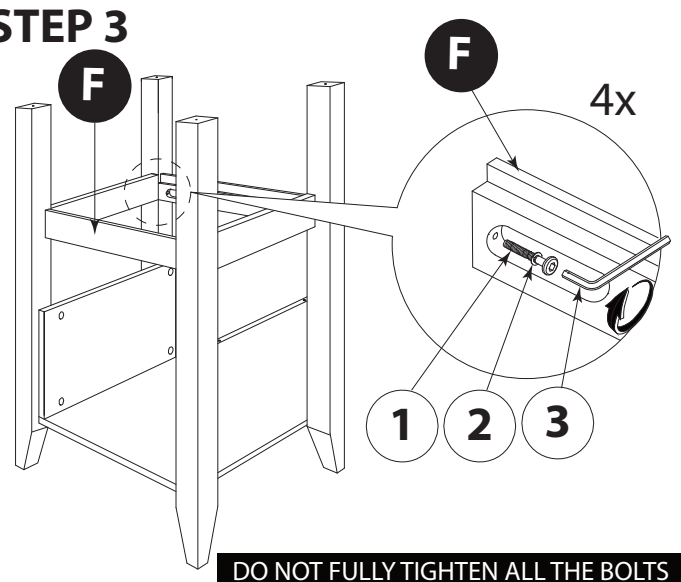

## STEP 4

REAR VIEW

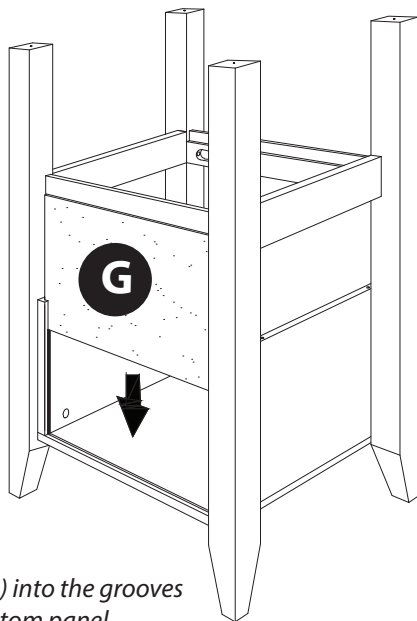

## STEP 5

FRONT VIEW

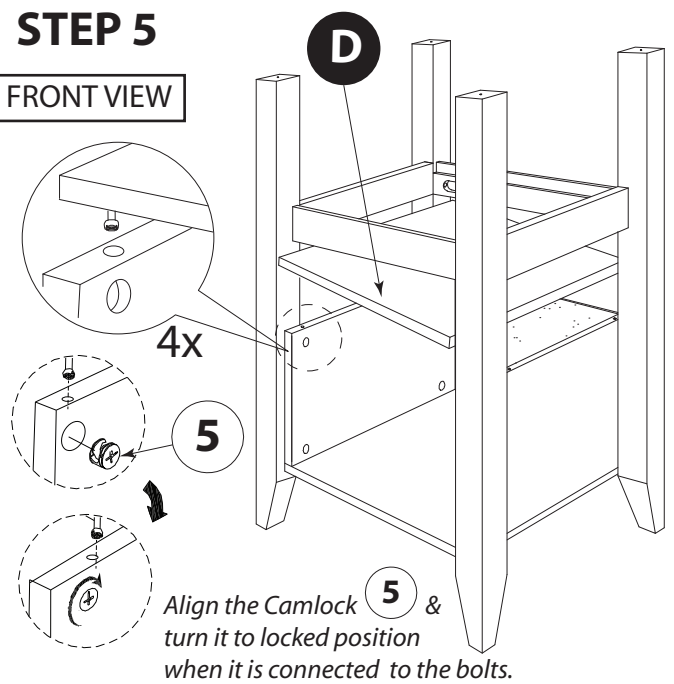

## STEP 6

**ENSURE TO FULLY TIGHTEN ALL THE BOLTS BEFORE PLACING THE GLASS TOP**

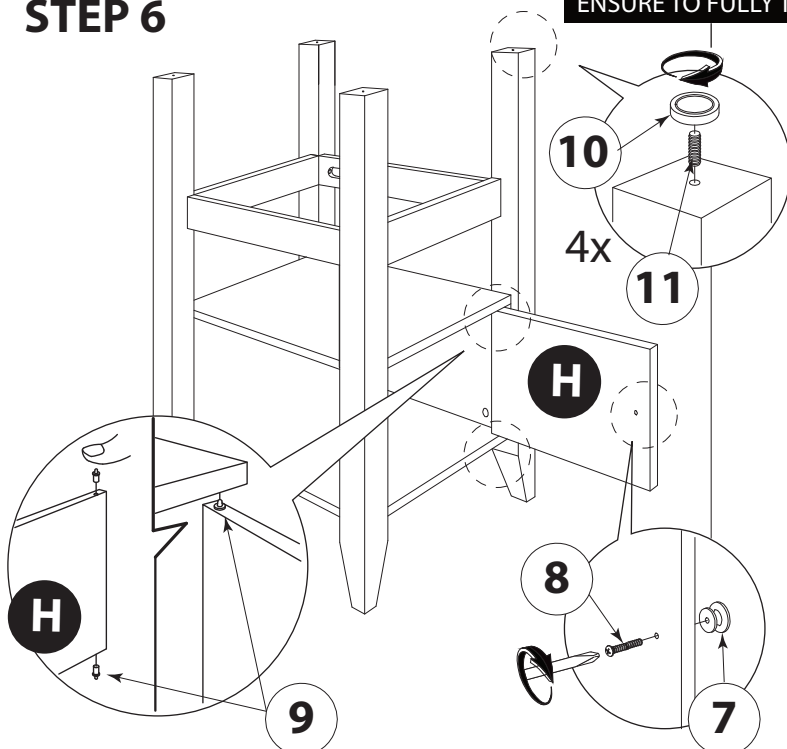

## STEP 7

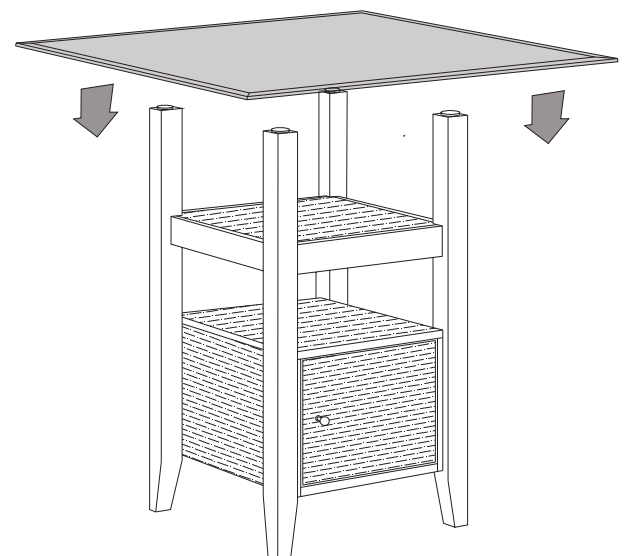

With the help of at least two adults, lift the glass tabletop carefully, and place it proportionately onto the pedestal so that the glass tabletop sits firmly on the aluminium discs.