

ASSEMBLY INSTRUCTIONS

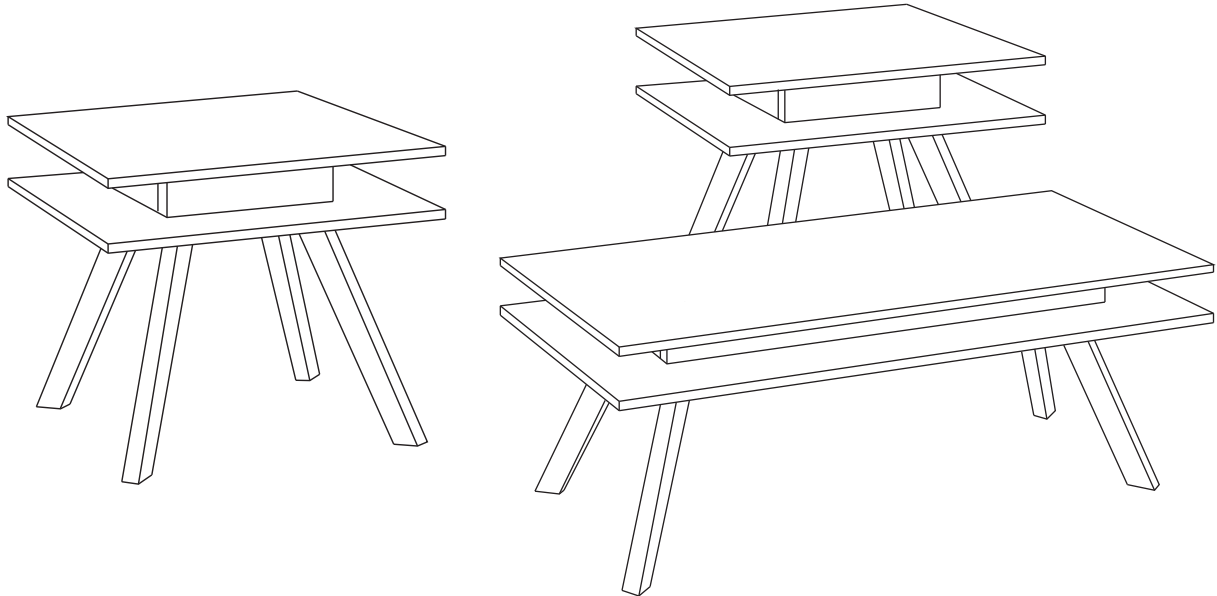

OCCASIONAL TABLE



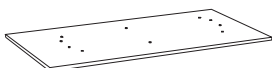
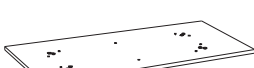
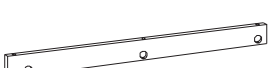

NOTE TO CUSTOMERS:

- For ease and speed of assembly we recommend that before you commence each step of the assembly that you identify all the parts required to complete that step.
- We recommend that where possible you allow sufficient space to assemble the item as close as possible to the place where it will be once assembled.
- For the protection of your furniture we recommend that the product is placed on a dry, soft, smooth and clean surfaces during assembly to prevent any damage. Avoid damp and direct sunlight.
- During assembly do not over tighten the screws or bolts, as this may damage the product.
- Please ensure you retain all the product packaging until the item is completely assembled.
- Periodically check all fitting and re-tighten as necessary.
- Never allow any liquids to remain on your furniture as absorption can cause the wood to warp or finish to de-laminate.
- It is recommended that this item should be assembled by two adults.

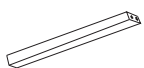

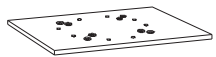

PARTS IDENTIFICATION : COFFEE TABLE

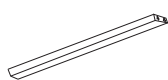
A Quantity: 1  Table Top	B Quantity: 1  Lower Panel	C Quantity: 2  Long Apron	D Quantity: 2  Short Apron	E Quantity: 4  Legs (Short)
---	--	---	--	---

PARTS IDENTIFICATION : TWO END TABLES

F Quantity: 2  Table Top (Small)	G Quantity: 2  Lower Panel (Small)	H Quantity: 4  Short Apron (Right)	I Quantity: 4  Short Apron (Left)	J Quantity: 8  Legs (Long)
--	--	--	---	--

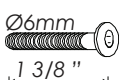
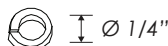
HARDWARE LIST (Quantity for all the three tables)

1 Quantity: 26  Camlock	2 Quantity: 26  Connecting Bolts	3 Quantity: 50  JCBC Bolts m6 x 35mm	4 Quantity: 42  Spring Washer	5 Quantity: 1  Allen Key
---	--	--	--	--

ASSEMBLE THE END TABLES

STEP 1 Align connecting bolts

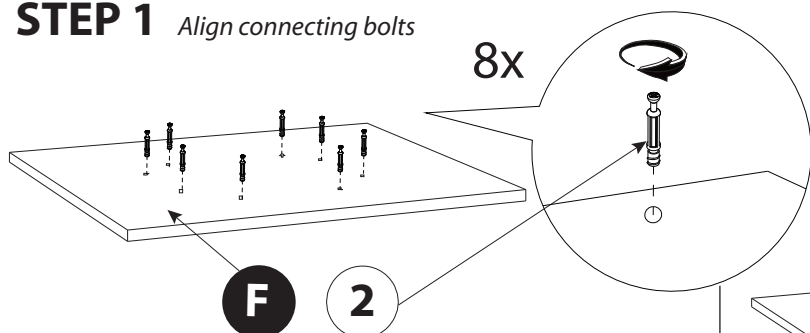

STEP 3 Assemble the Legs to the Lower Panel G

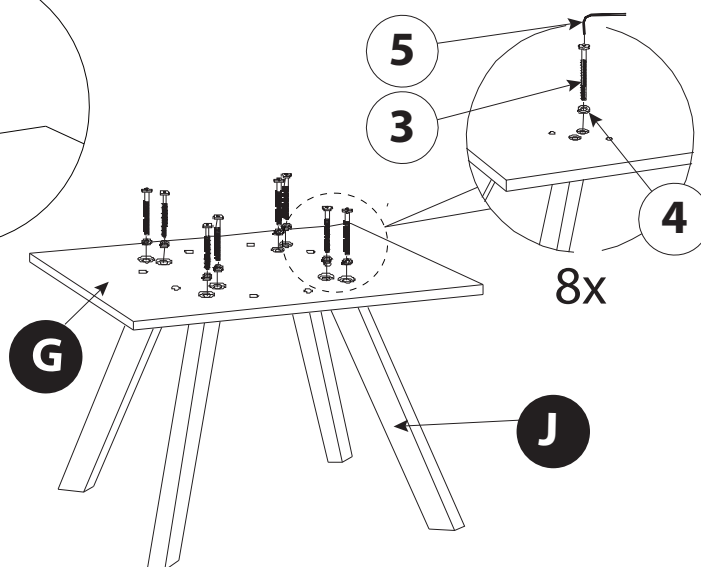

STEP 2 Attach the Aprons.

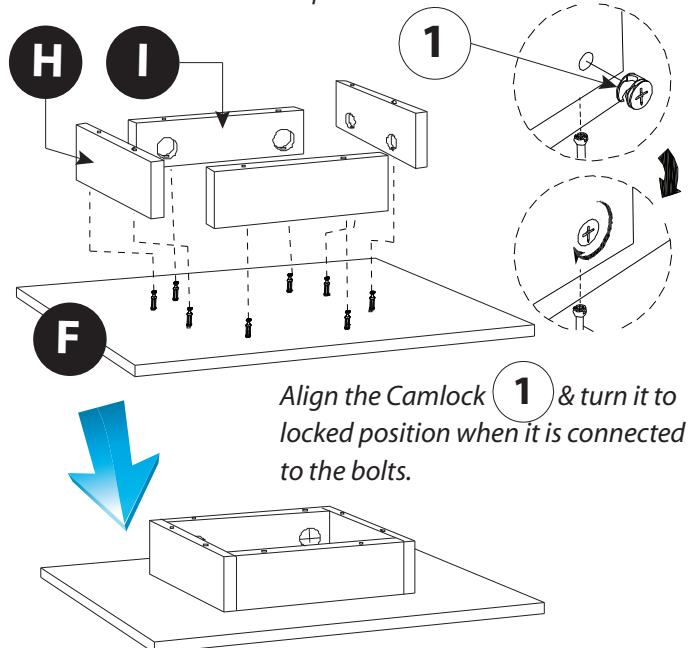

STEP 4

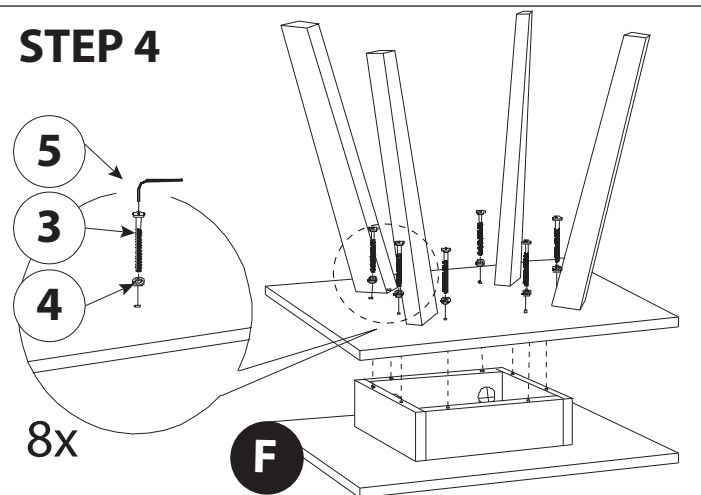

ASSEMBLE THE COFFEE TABLE

STEP 1 *Align connecting bolts*

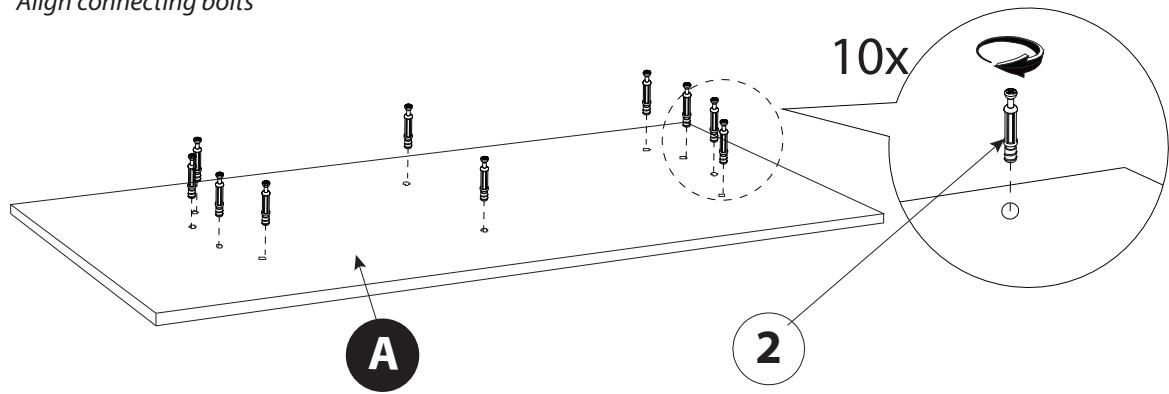

STEP 2 *Attach the Aprons.*

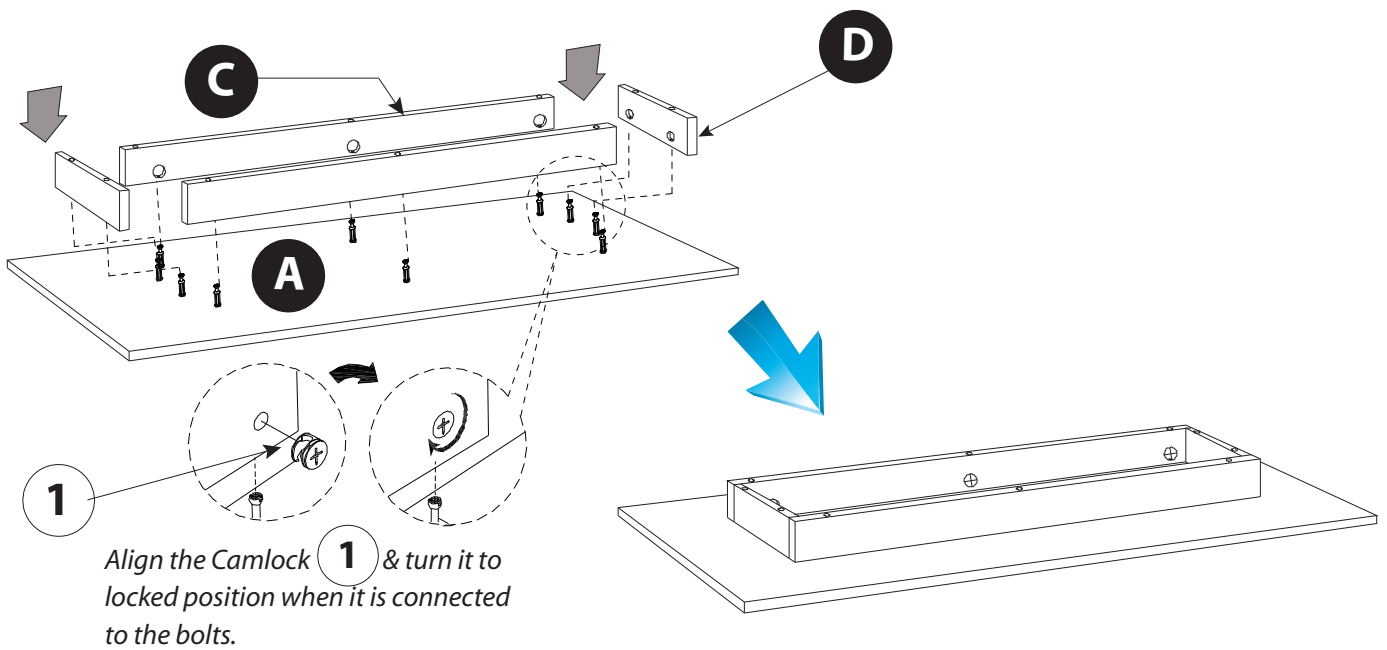

STEP 3 *Assemble the Legs to the Lower Panel B*

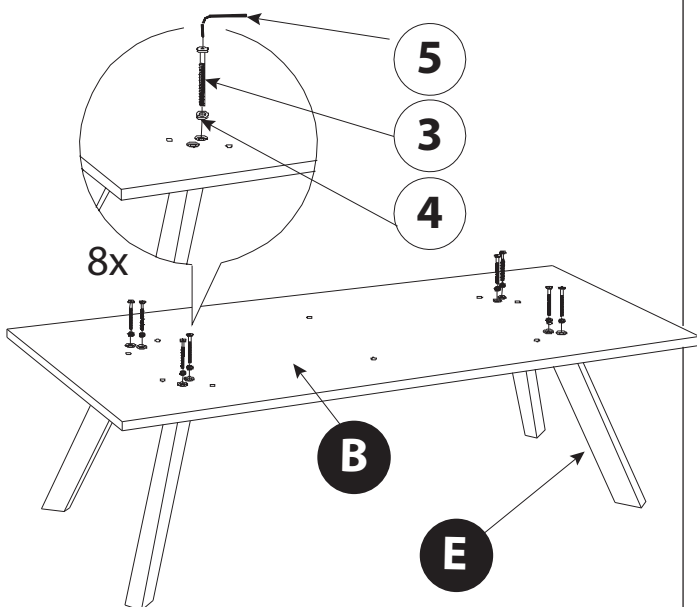

STEP 4

