

ASSEMBLY INSTRUCTIONS

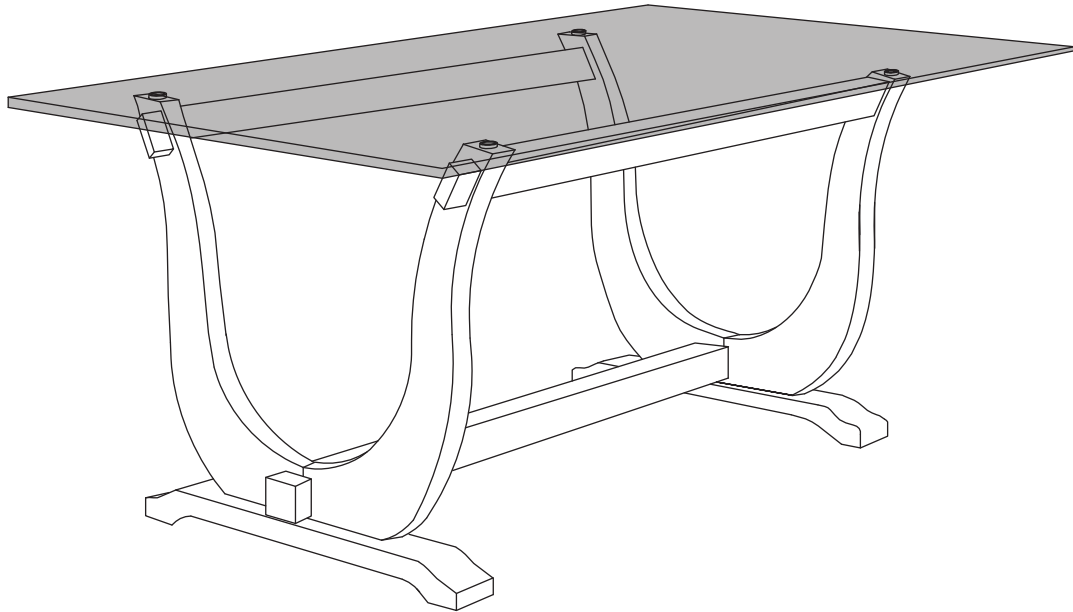



DINING TABLE





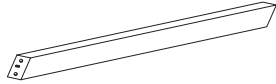
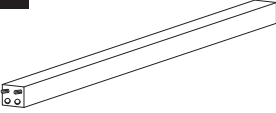
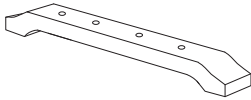

NOTE TO CUSTOMERS:

- For ease and speed of assembly we recommend that before you commence each step of the assembly that you identify all the parts required to complete that step.
- We recommend that where possible you allow sufficient space to assemble the item as close as possible to the place where it will be once assembled.
- For the protection of your furniture we recommend that the product is placed on a dry, soft, smooth and clean surfaces during assembly to prevent any damage. Avoid damp and direct sunlight.
- During assembly do not over tighten the screws or bolts, as this may damage the product.
- Please ensure you retain all the product packaging until the item is completely assembled.
- Periodically check all fitting and re-tighten as necessary.
- Never allow any liquids to remain on your furniture as absorption can cause the wood to warp or finish to de-laminate.
- It is recommended that this item should be assembled by two adults.

PARTS IDENTIFICATION

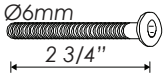
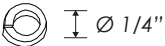
CARTON A	A Quantity: 1  Glass Table Top	CARTON B	B Quantity: 2  Curvy Leg (with mortise)	C Quantity: 2  Curvy Leg (with tenon)	D Quantity: 2  Upper Support Rails
	E Quantity: 1  Bottom stretcher		F Quantity: 2  Trestle Leg Support	G Quantity: 4  Wood Cleat for Upper Rail	H Quantity: 2  Wood Cleat for Bottom Stretcher

HARDWARE LIST

1 Quantity: 20  JCBC Bolt m6 x 60mm	2 Quantity: 20  Spring Washer 1/4"	3 Quantity: 4  Alum. Disc Glass Top adapter.	4 Quantity: 4  Bolt for Alum. Disc	5 Quantity: 4  Leg Adjustable Glide
---	--	--	--	---

6 Quantity: 1

Allen Key

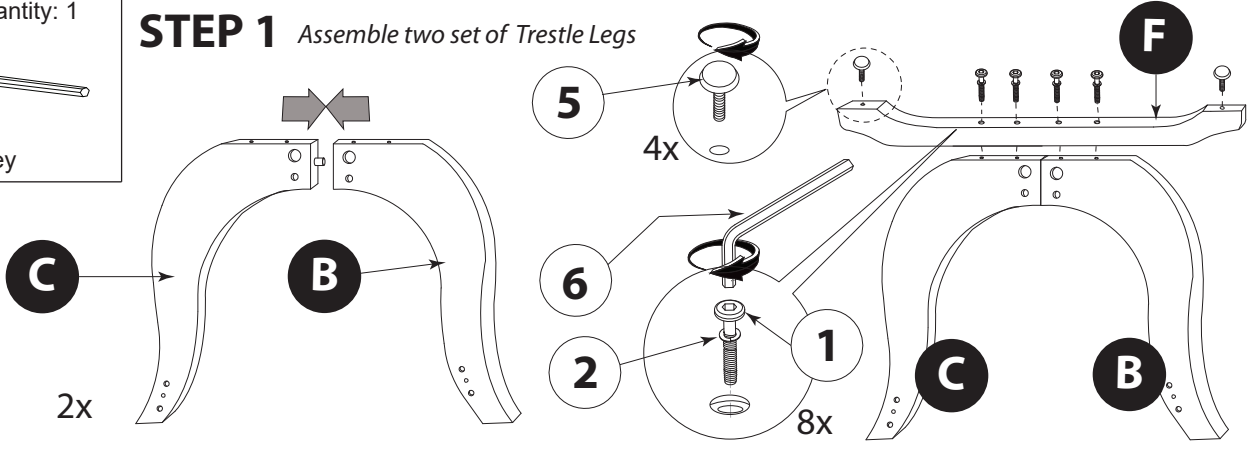
STEP 1 Assemble two set of Trestle Legs

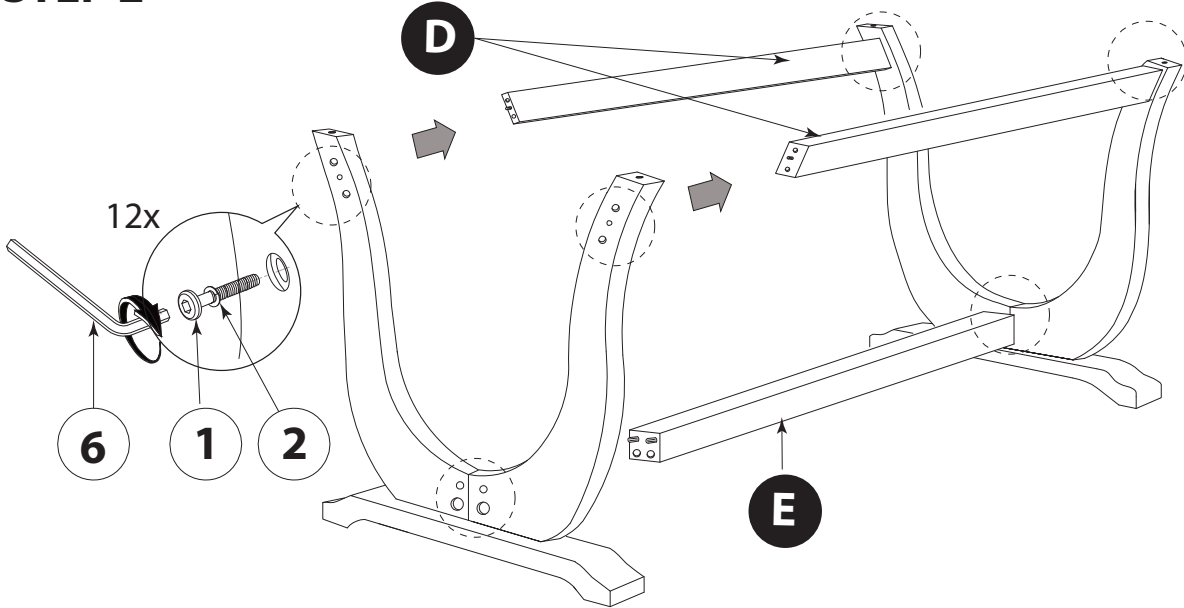

STEP 2



STEP 3

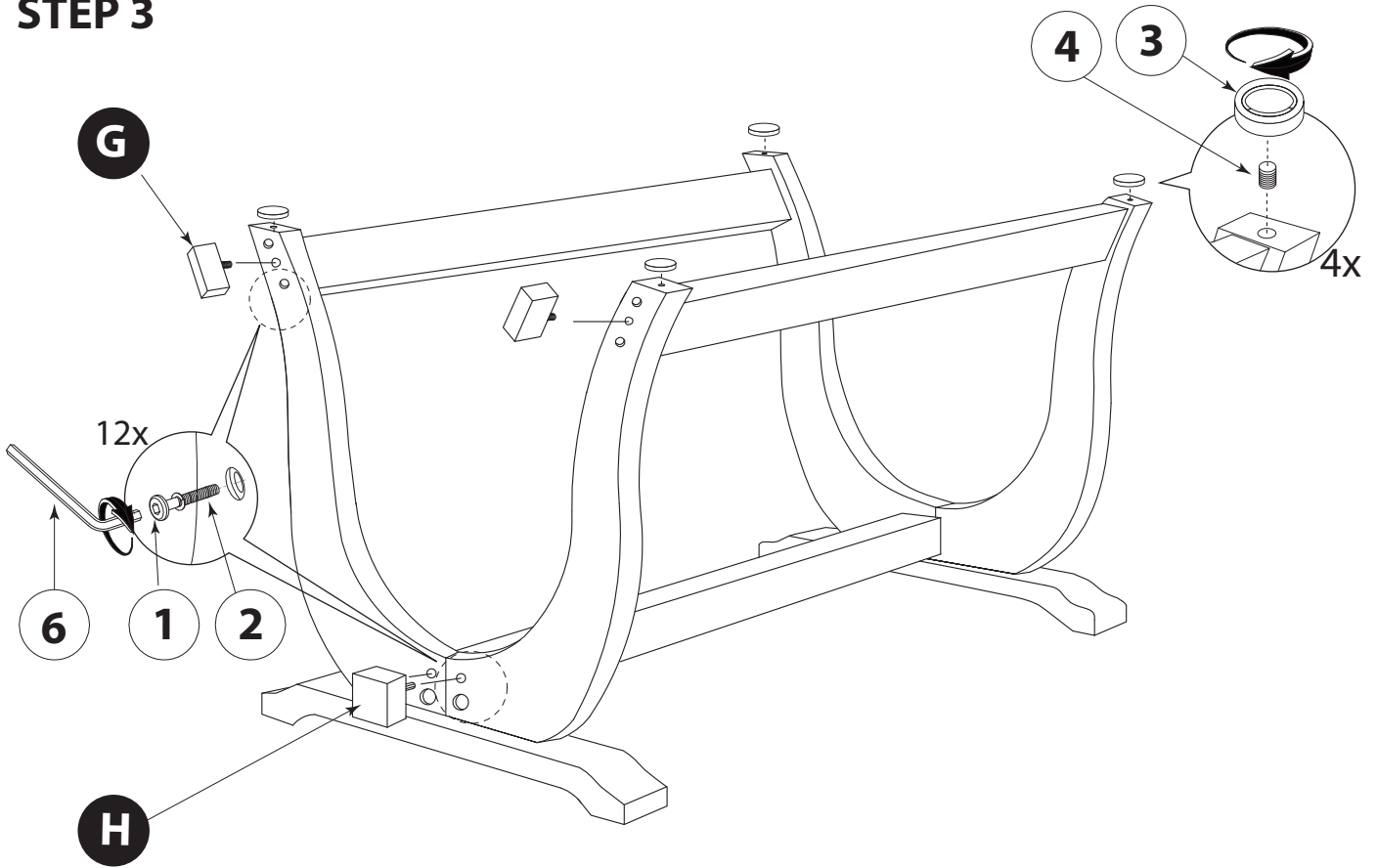

STEP 4

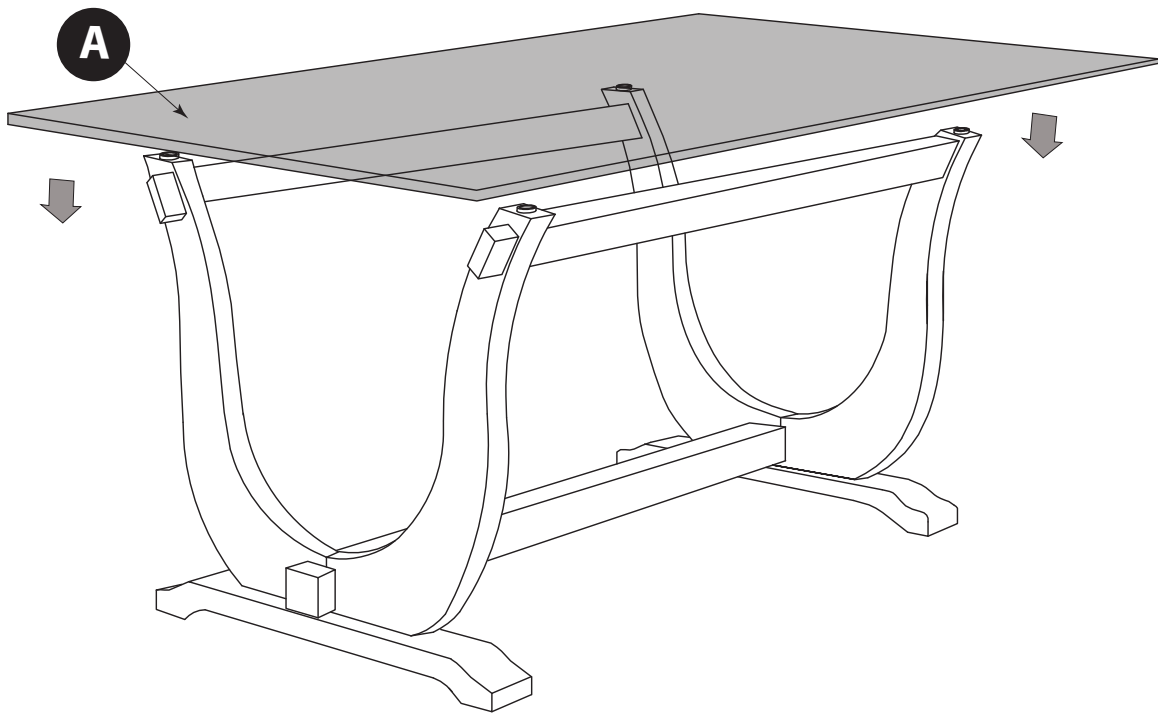

With the help of at least two adults, lift the glass tabletop carefully, and place it proportionately onto the table legs so that the glass tabletop sits firmly on the aluminium discs.