

ASSEMBLY INSTRUCTIONS

Style # C1423 Console Table

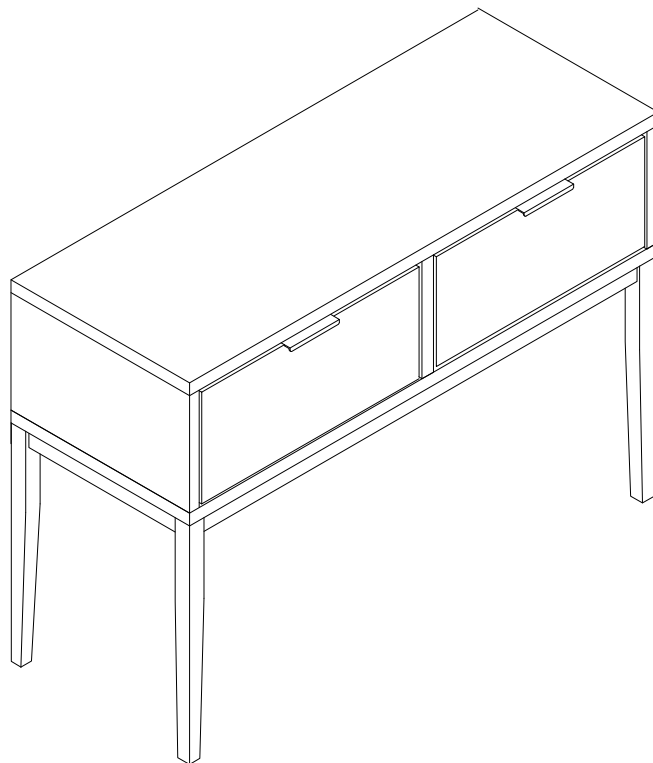

NOTE TO CUSTOMERS:

- For ease and speed of assembly we recommend that before you commence each step of the assembly that you identify all the parts required to complete that step.
- We recommend that where possible you allow sufficient space to assemble the item as close as possible to the place where it will be once assembled.
- For the protection of your furniture we recommend that the product is placed on protected surfaces during assembly to prevent any damage.
- During assembly do not over tighten, as this may damage the product.
- Please ensure you retain all the product packaging until the item completely assembled.
- Please periodically check all fittings and re-tighten as necessary.
- Please never allow any liquids to remain on your furniture as absorption can cause the wood to warp or finish to de-laminate.

To insert a cam lock: (Please read below instructions before assembling)

	<p>Diagram A</p>	<p>1. Insert cam screw into hole as shown in diagram A .</p>
	<p>Diagram B</p>	<p>Make sure not to insert the cam screw: Too deep as shown in figure B as this will cause the cam screw to be misaligned and unable to interlock properly.</p>
	<p>Diagram C</p>	<p>Also avoid inserting the cam screw too close to the surface of the hole as shown in figure C, as this will cause the cam lock to be too loose, and not interlock properly.</p>

	<p>2. Connect the panels together.</p>
<p>ARROW SIGN</p>	<p>3. When inserting the cam lock make sure the arrow of the cam lock faces the cam screw.</p>
	<p>4. To tighten the cam lock turn the cam lock clockwise 90-180 degree or until the arrow is facing opposite the place cam lock was inserted.</p> <p>NOTE: DO NOT USE AN AUTOMATIC SCREWDRIVER TO TIGHTEN CAM LOCKS.</p>







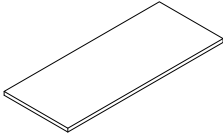
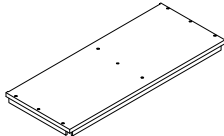
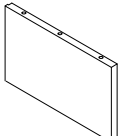
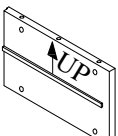
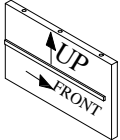
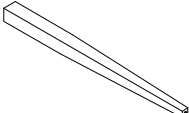
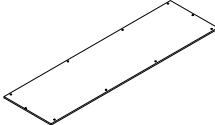
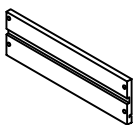
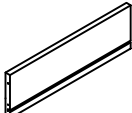
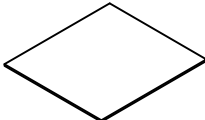
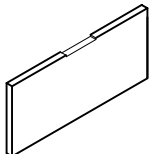

Note:

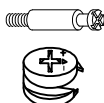
- Read these instructions carefully before assembling.
- Tools required : Phillips screwdriver, flat screwdriver.
- Find a clean, smooth area on which to work , such as a carpet, in order to avoid scratching the wood surfaces.
- Wait to dispose of the packing material until assembly is complete and all parts and hardware are accounted for.
- Two or more people might be required for assembly.

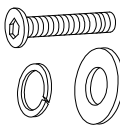
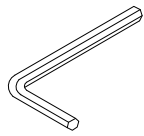
Part List

A1 Quantity of 4	A2 Quantity of 1	A3 Quantity of 1	A4 Quantity of 1
			
Top Panel	Bottom Panel	Left Side Panel	Right Side Panel
A5 Quantity of 1	A6 Quantity of 4	A7 Quantity of 1	A8 Quantity of 4
			
Divider	Leg	Back Panel	Drawer Side Panel
A9 Quantity of 2	A10 Quantity of 2	A11 Quantity of 2	
			
Drawer Back Panel	Drawer Bottom Panel	Drawer Front Panel	

Hardware List

B1 Quantity of 12	B2 Quantity of 6	B3 Quantity of 2	B4 Quantity of 8	B5 Quantity of 1
				
Cambolt & Camlock	Wood Dowel	Stopper with screw	Bolt & Washer	Allen wrench
B6 Quantity of 10	B7 Quantity of 16	B8 Quantity of 2	B9 Quantity of 1	B10 Quantity of 1
				
Screw	Screw	Handle & Screw	Anchor with Screw	Anti-tip kit

Step 1

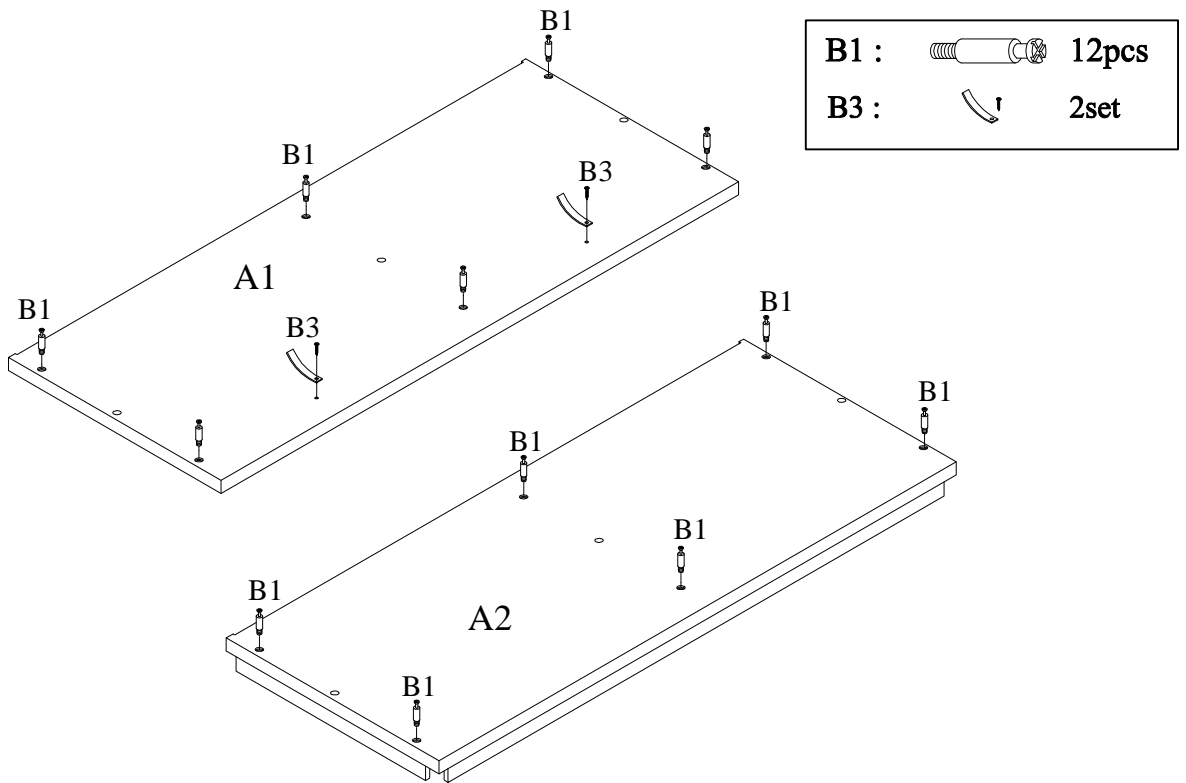

- 1). Attach and tighten Cam-Bolts B1 to Top Panel A1 & Bottom Panel A2 as shown above.
- 2). Attach Drawer Stoppers B3 to the bottom of Top Panel A1 by included screws as shown above.

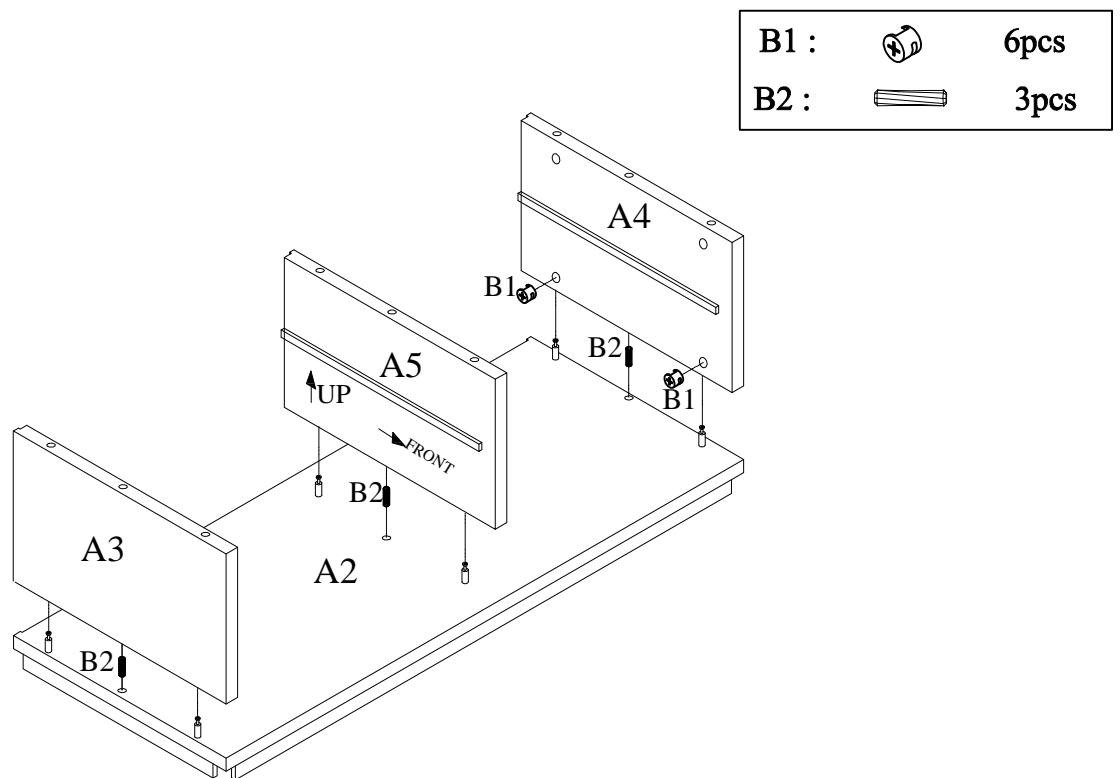

Step 2

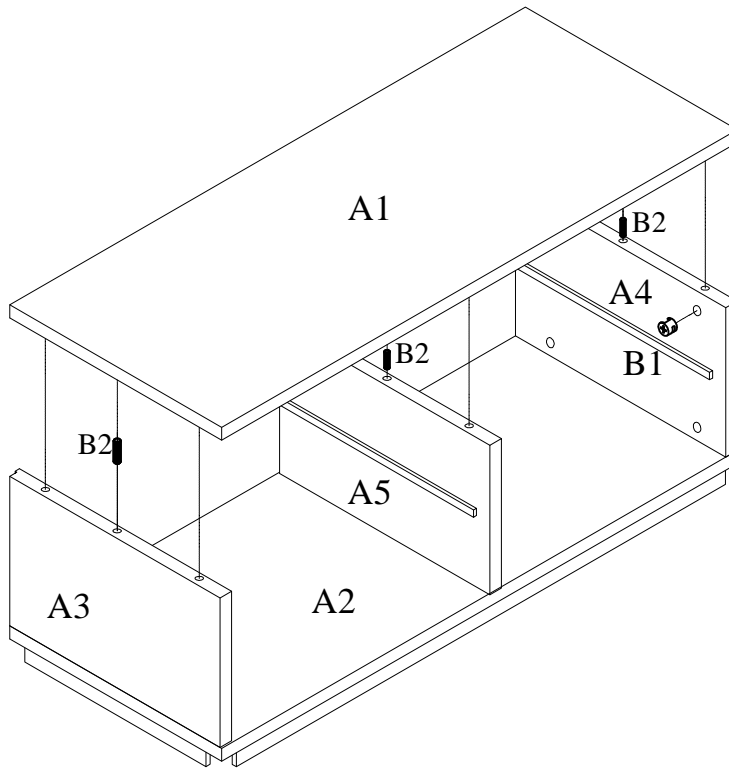

Assemble Side Panels A3 & A4 and Divider A5 to Bottom Panel A2 by Wood Dowel B2 and Cam-nut B1 with inserted Cam-bolts as shown above.

Step 3





B1 :		6pcs
B2 :		3pcs

Assemble Top Panel A1 to Side Panels A3 & A4, Divider A5 using Cam-lock B1 and Wood Dowel B2 as shown above

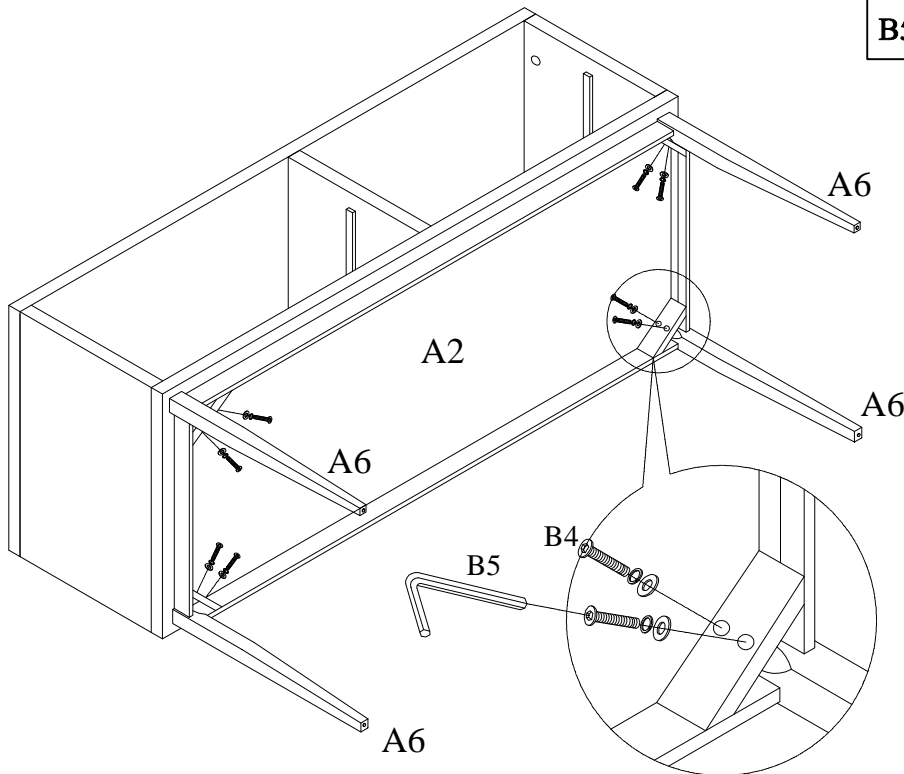
Step 4



B4 :		8set
B5:		1pc

Assemble Legs A6 to Bottom Panel A2 using Bolts B4 with washers as shown above.

Step 5

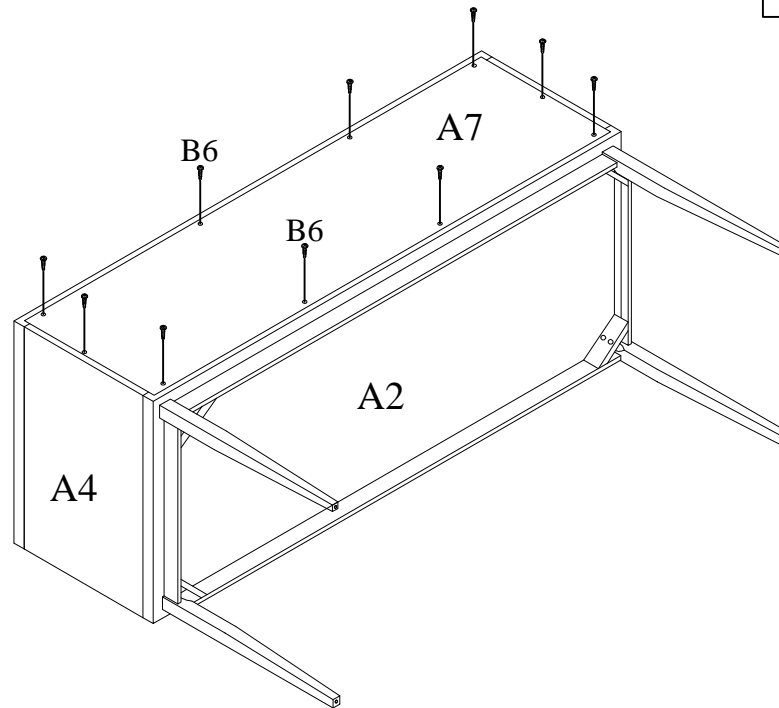

B6:  10pcs



Assemble Back Panel A7 to the back of Side Panels A3 & A4, Top Panel A1 and Divider A5 using Screws B6 as shown above.

Step 6

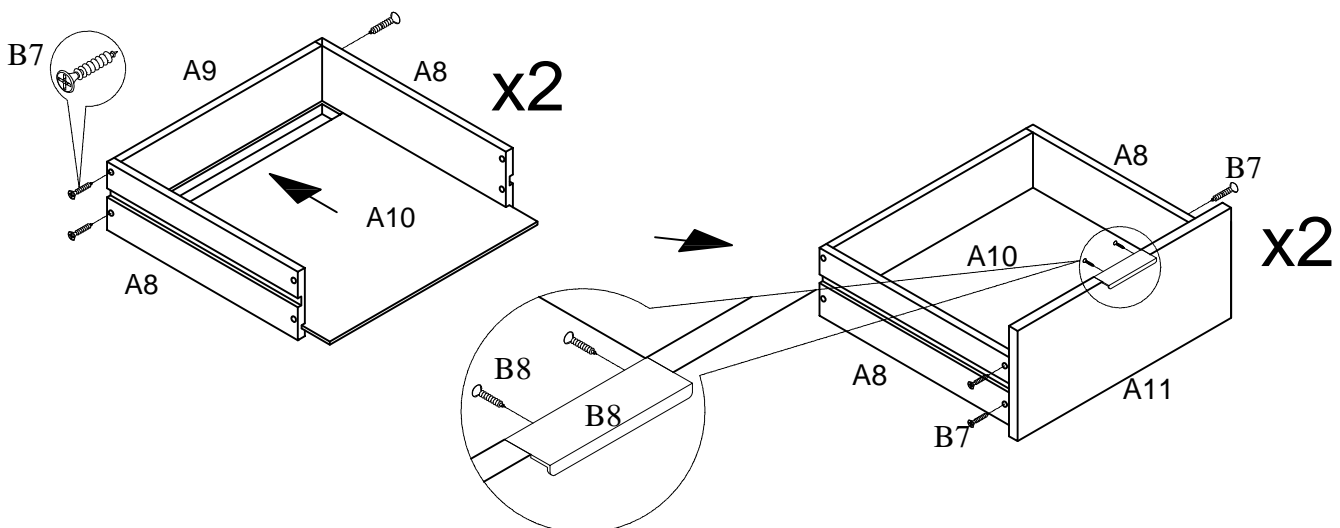

B7:  16pcs

B8:    2set



- 1). Assemble Drawer Side Panels A8 to Drawer Back Panel A9 using Screws B7.
- 2). Insert Drawer Bottom Panel A10 into grooves on Drawer Side Panels A8 and Drawer Back Panel A9.
- 3). Assemble Drawer Front Panel A11 to Drawer Side Panels A8 using Screws B7
- 4). Assemble Handles B8 to Drawer Front Panel by included screws.

Step 7

- B9 :  1pc
 B10:  1pc

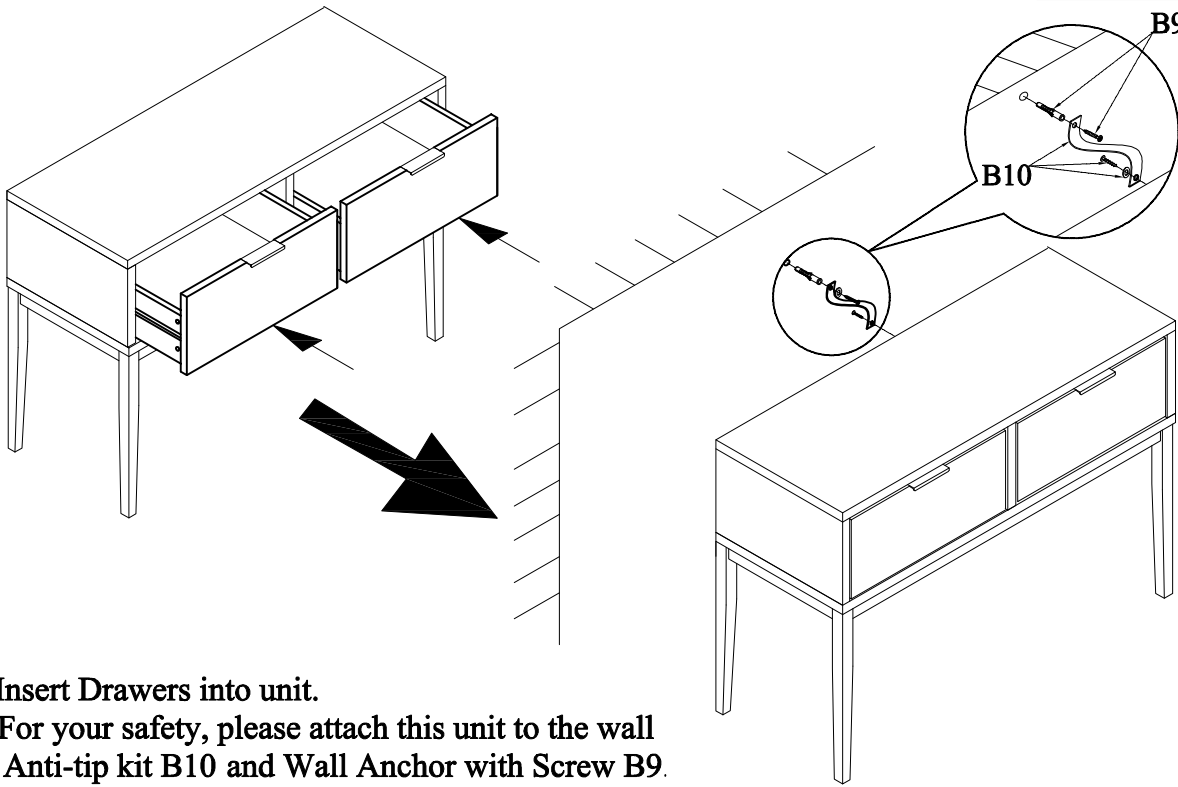

- 1). Insert Drawers into unit.
- 2). For your safety, please attach this unit to the wall by Anti-tip kit B10 and Wall Anchor with Screw B9.

APPENDIX: Dimension of Hardwares in this AI.

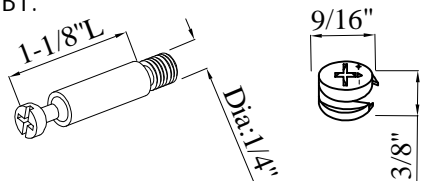
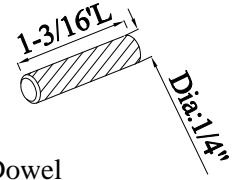
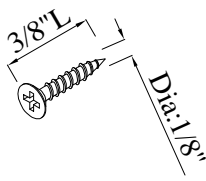
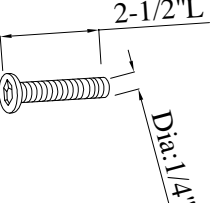
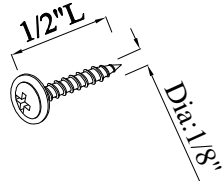
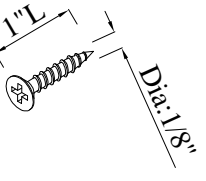
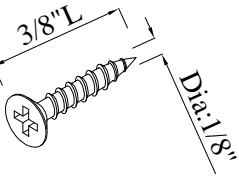
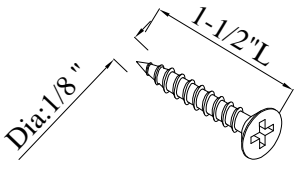
<p>B1.</p>  <p>Cambolt & Camlock</p>	<p>B2.</p>  <p>Wood Dowel</p>	<p>B3.</p>  <p>Screw</p>
<p>B4.</p>  <p>Bolt</p>	<p>B6.</p>  <p>Screw</p>	<p>B7.</p> 
<p>B8.</p>  <p>Screw</p>	<p>B9.</p>  <p>Screw</p>	