

# ASSEMBLY INSTRUCTIONS

## Style # R1126 Large Step Stool

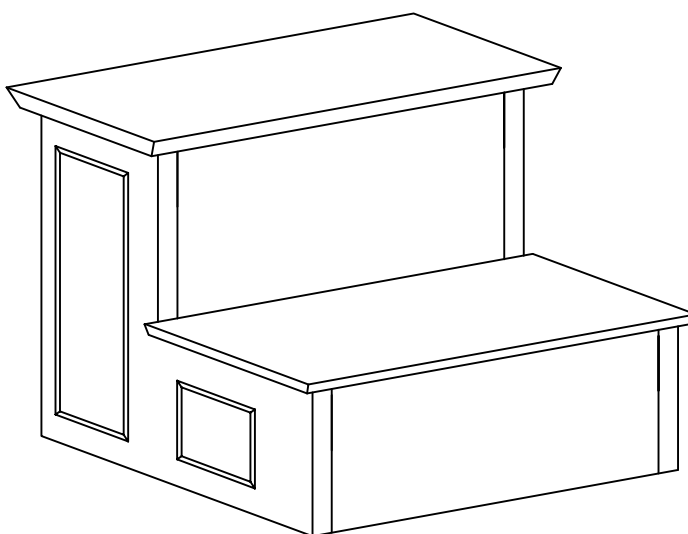

### NOTE TO CUSTOMERS:

- For ease and speed of assembly we recommend that before you commence each step of the assembly that you identify all the parts required to complete that step.
- We recommend that where possible you allow sufficient space to assemble the item as close as possible to the place where it will be once assembled.
- For the protection of your furniture we recommend that the product is placed on protected surfaces during assembly to prevent any damage.
- During assembly do not over tighten, as this may damage the product.
- Please ensure you retain all the product packaging until the item completely assembled.
- Please periodically check all fittings and re-tighten as necessary.
- Please never allow any liquids to remain on your furniture as absorption can cause the wood to warp or finish to de-laminate.
- It is recommended that this item should be assembled by two adults.

## Parts List:

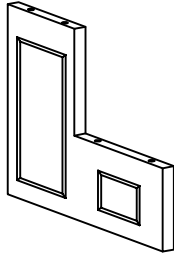

A1(L/R): Side Panel  
2PCS

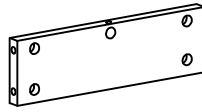

A2: Upper Front Panel  
1PC

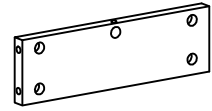

A3: Lower Front Panel  
1PC



A4: Back Apron  
1PC

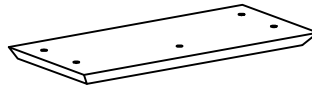

A5: Upper Top Panel  
1PC

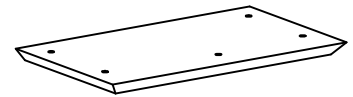

A6: lower Top Panel  
1PC

## Hardware List:

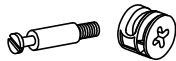

B1:Camlock 20SETS



B2: Wood Dowel 2PCS



B3:Glue 1PC

## Note:

- Read these instructions carefully before assembling.
- Tools required : Phillips screwdriver.
- Find a clean, smooth area on which to work , such as a carpet, in order to avoid scratching the wood surfaces.
- Wait to dispose of the packing material until assembly is complete and all parts and hardware are accounted for.
- Two or more people might be required for assembly.

## To use Dowels:

1. Add glue (about  $\frac{1}{4}$  full ) in the hole(s) of each board to be joined.
2. Insert the Dowel(s) and join boards.
3. Wipe excess glue with a damp paper towel.

## To use Cam Locks:

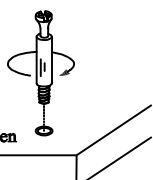
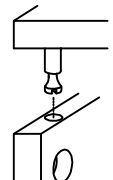
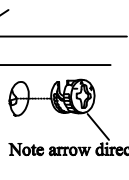
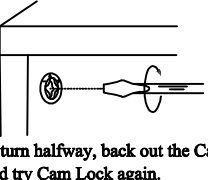
<p>1. Insert Cam Pin until snug</p>  <p>Do not over-tighten</p>	<p>2. Set boards together</p> 	<p>3. Insert Cam Lock</p>  <p>Note arrow direction</p>	<p>4. Turn Cam Lock clockwise (half a turn)</p>  <p>if it won't turn halfway, back out the Cam Pin <math>\frac{1}{4}</math> turn and try Cam Lock again.</p>
--	---	--	---

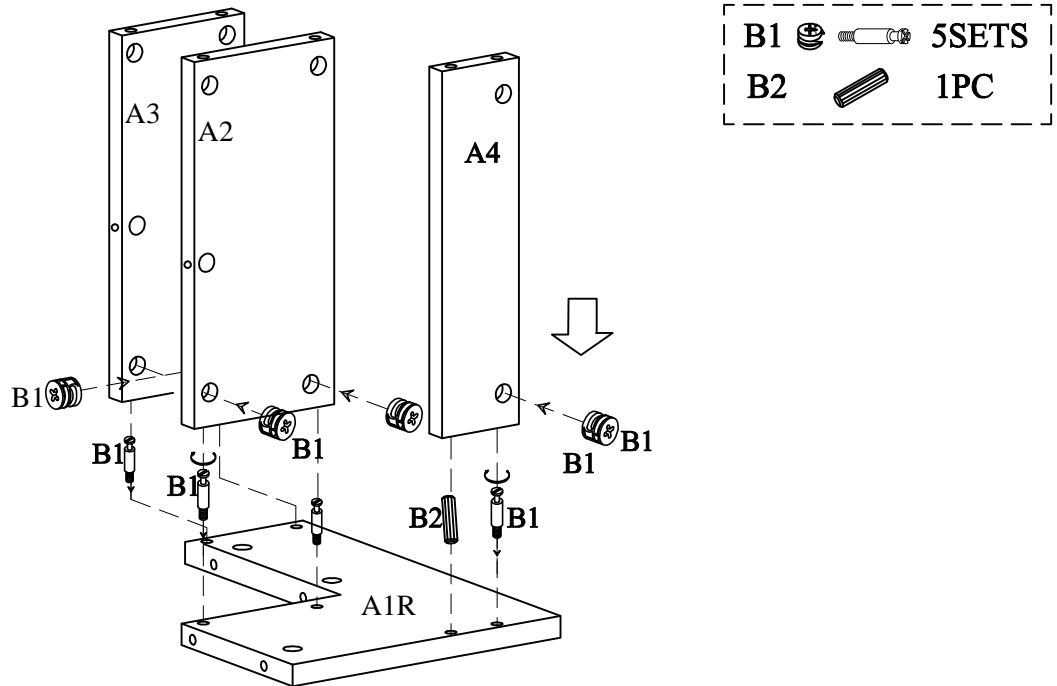

**Step 1: Assemble Upper Front Panel A2, Lower Front Panel A3 to Side Panel A1R using Camlocks B1. Then assemble Back Apron A4 to Side Panel A1R using Camlocks B1 and Wood Dowels B2.**

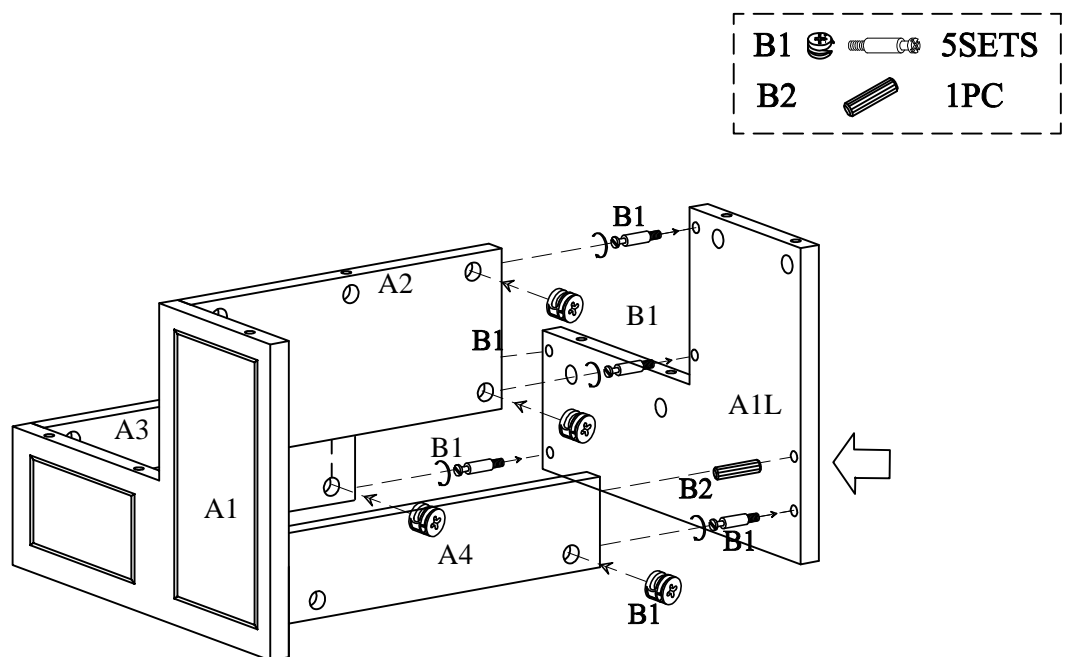

**Step 2: Repeat step 1 to assemble Upper Front Panel A2, Lower Front Panel A3 and Back Apron A4 to Side Panel A1L.**



Step 3: Assemble Upper Top Panel A5 and Lower Top Panel A6 to Side Panels A1 and Front Panels A2&A3 using Camlocks B1.

B1   10SETS

