

# ASSEMBLY INSTRUCTIONS

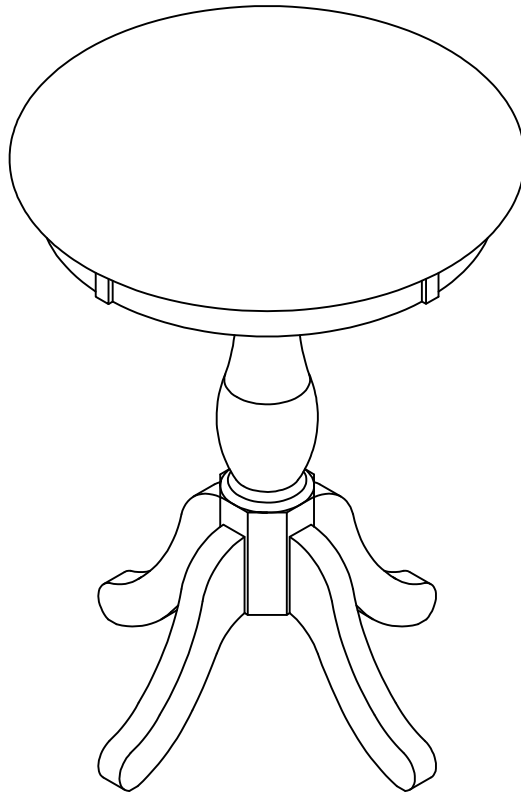

Style # PS29&PS30 Plant Stand





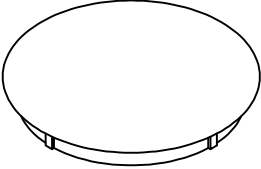
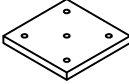

## NOTE TO CUSTOMERS:

- For ease and speed of assembly we recommend that before you commence each step of the assembly that you identify all the parts required to complete that step.
- We recommend that where possible you allow sufficient space to assemble the item as close as possible to the place where it will be once assembled.
- For the protection of your furniture we recommend that the product is placed on protected surfaces during assembly to prevent any damage.
- During assembly do not over tighten, as this may damage the product.
- Please ensure you retain all the product packaging until the item completely assembled.
- Please periodically check all fittings and re-tighten as necessary.
- Never allow any liquids to remain on your furniture as absorption can cause the wood to warp or the finish to de-laminate.
- It is recommended that this item should be assembled by two adults.

# Part List

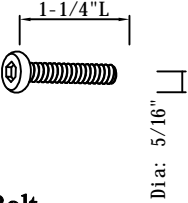
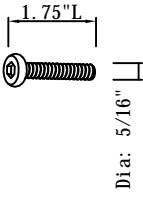
|  |   |  |   |
|--|---|--|---|
| <b>A1</b><br>Quantity<br>of 1<br><br><b>Table Top</b> | <b>A2</b><br>Quantity<br>of 1<br><br><b>Connecting Panel</b> | <b>A3</b><br>Quantity<br>of 1<br><br><b>Center Post</b> | <b>A4</b><br>Quantity<br>of 4<br><br><b>Legs</b> |
|--|---|--|---|

# Hardware List

|   |   |   |   |   |
|---|---|---|---|---|
| <b>B1</b><br>Quantity<br>of 4<br><br><b>Bolt</b> | <b>B2</b><br>Quantity<br>of 4<br><br><b>Bolt</b> | <b>B3</b><br>Quantity<br>of 5<br><br><b>Spring Washers</b> | <b>B4</b><br>Quantity<br>of 5<br><br><b>Flat Washers</b> | <b>B3</b><br>Quantity<br>of 1<br><br><b>Allen Wrench</b> |
|---|---|---|---|---|

## Step 1:

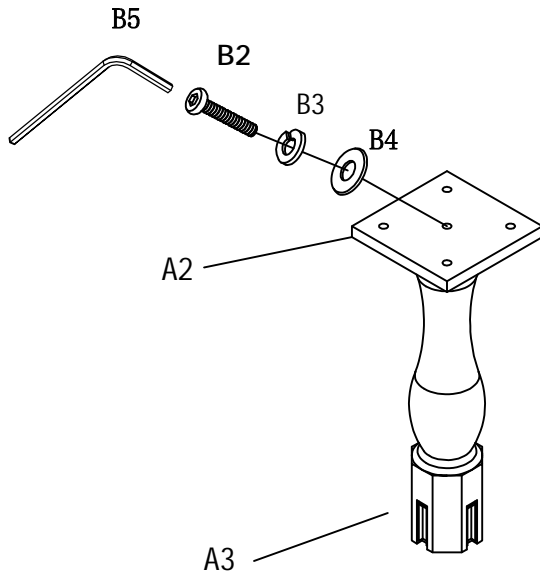

B2:  1pc

B3:  1pc

B4:  1pc

B5: 

Assemble Connecting Panel A2 to Center Post A3 using bolt B2 with spring washer B3 and flat washer B4 by a Allen Wrench B5.

## Step 2:

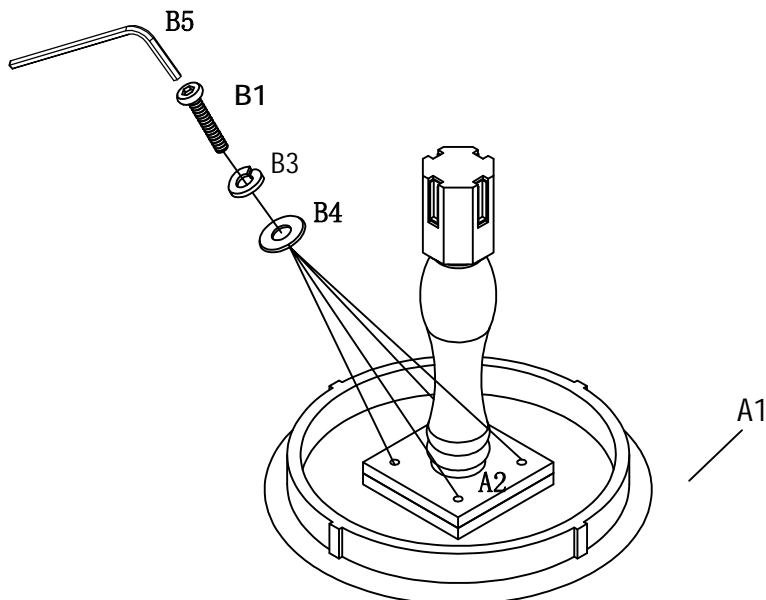

B1:  4pcs

B3:  4pcs

B4:  4pcs

B5: 

Assemble Connecting Panel A2 to Table Top A1 using bolts B1 with spring washers B3 and flat washers B4 by a Allen Wrench B5.

### Step 3:

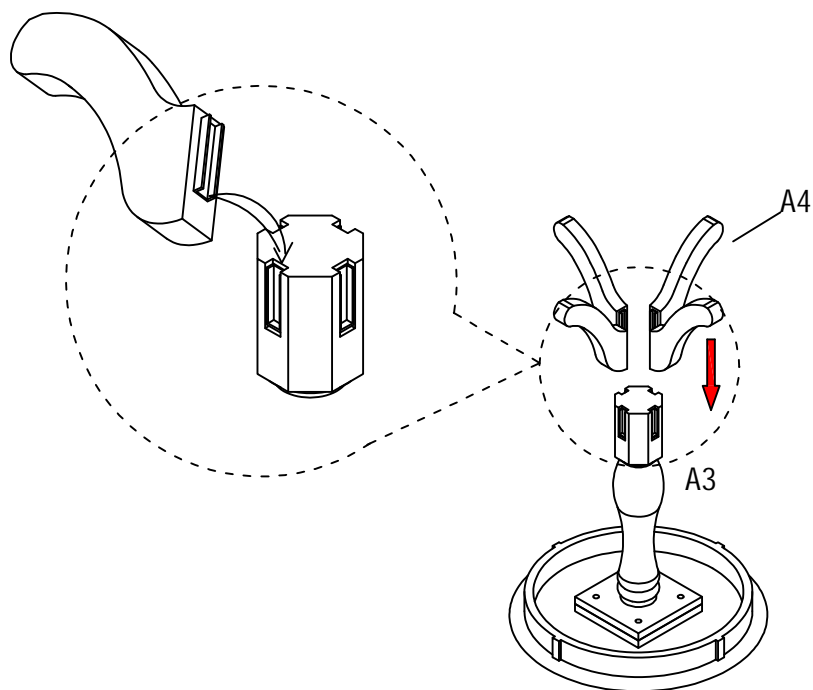

Insert Legs A4 into Center Post A3, please make sure the metal bracket on the legs fit properly into the grooves on the center post.

### Step 4:

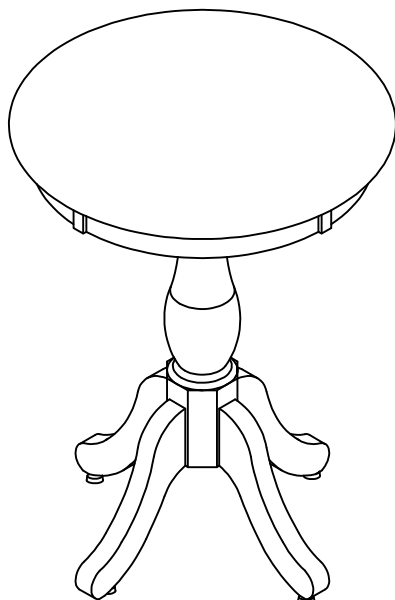

Please adjust the levelers on the legs if this table is not stable.