

# ASSEMBLY INSTRUCTIONS

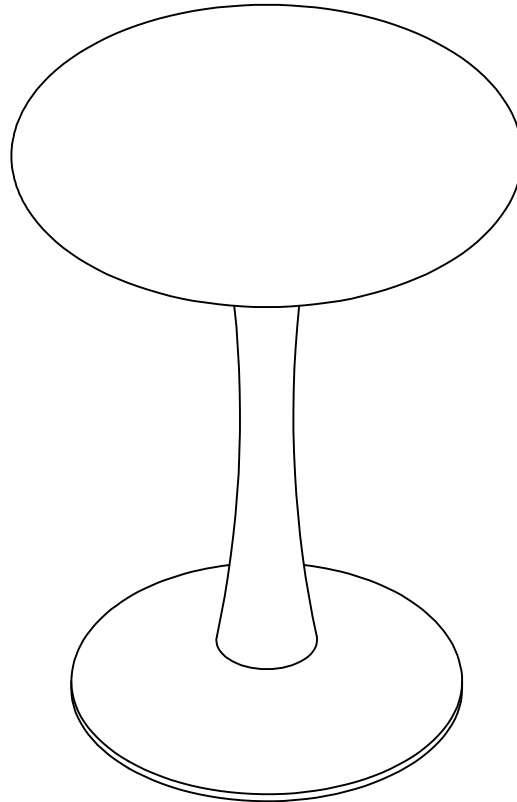

Style # PS27&PS28 Plant Stand





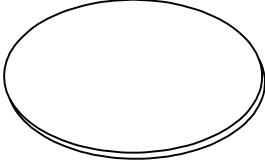

## NOTE TO CUSTOMERS:

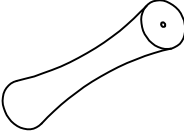
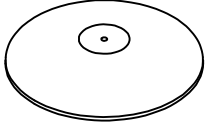
- For ease and speed of assembly we recommend that before you commence each step of the assembly that you identify all the parts required to complete that step.
- We recommend that where possible you allow sufficient space to assemble the item as close as possible to the place where it will be once assembled.
- For the protection of your furniture we recommend that the product is placed on protected surfaces during assembly to prevent any damage.
- During assembly do not over tighten, as this may damage the product.
- Please ensure you retain all the product packaging until the item completely assembled.
- Please periodically check all fittings and re-tighten as necessary.
- Never allow any liquids to remain on your furniture as absorption can cause the wood to warp or the finish to de-laminate.
- It is recommended that this item should be assembled by two adults.

# Part List

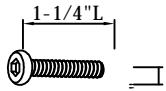
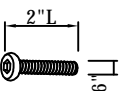
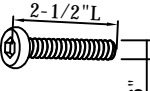
<b>A1</b>    <b>Top Panel</b>	<b>Quantity of 1</b>	<b>A2</b>    <b>Connecting Panel</b>	<b>Quantity of 1</b>	<b>A3</b>    <b>Support Bar</b>	<b>Quantity of 1</b>	<b>A4</b>    <b>Base</b>	<b>Quantity of 1</b>
--	----------------------	---	----------------------	---	----------------------	---	----------------------





# Hardware List

<b>B1</b>    <b>Bolt</b>  Dia: 5/16"	<b>Quantity of 3</b>	<b>B2</b>    <b>Bolt</b>  Dia: 5/16"	<b>Quantity of 1</b>	<b>B3</b>    <b>Bolt</b>  Dia: 5/16"	<b>Quantity of 1</b>	<b>B4</b>    $\phi \frac{5}{16}$ " <b>Spring Washer</b>	<b>Quantity of 5</b>	<b>B5</b>    $\phi \frac{5}{16}$ " <b>Flat Washer</b>	<b>Quantity of 5</b>	<b>B6</b>    <b>Allen Wrench</b>	<b>Quantity of 1</b>
---	----------------------	---	----------------------	---	----------------------	---	----------------------	---	----------------------	---	----------------------

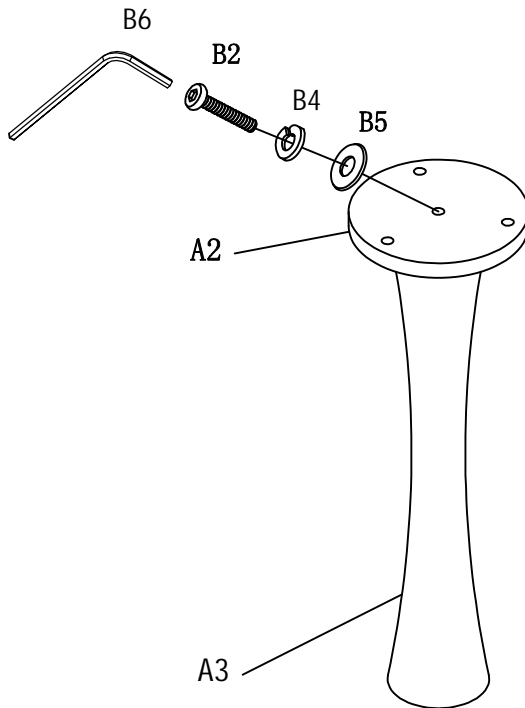
## Assembly instructions

### Step 1:



<b>B2:</b> 	<b>1pc</b>
<b>B4:</b> 	<b>1pc</b>
<b>B5:</b> 	<b>1pc</b>
<b>B6:</b> 	<b>1pc</b>

Assemble the connecting panel A2 to support bar A3 using bolt B2 with spring washer B4 & flat washer B5.

### Step 2:

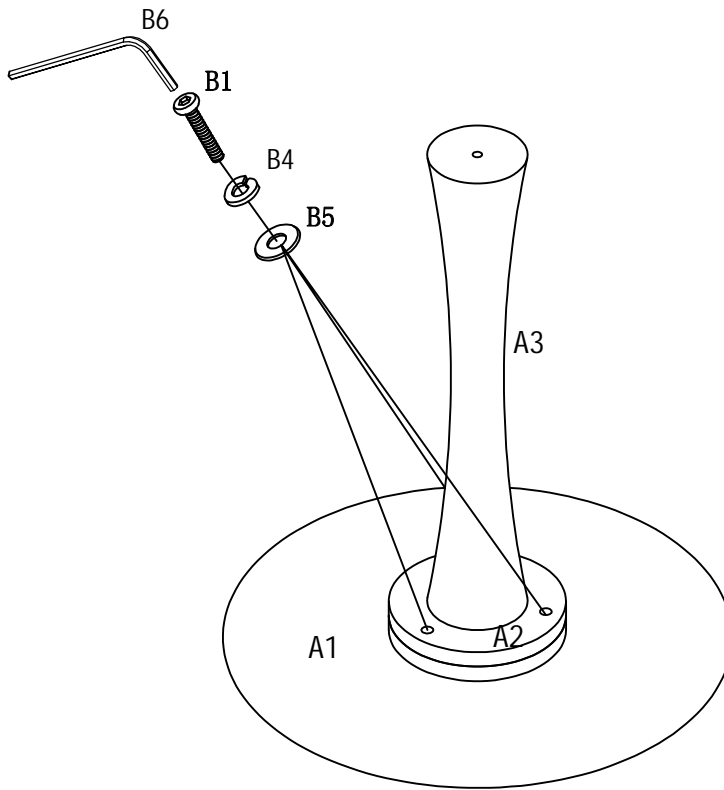

B1:  3pcs

B4:  3pcs

B5:  3pcs

B6:  1pc

Assemble the connecting panel A2 to the bottom of top panel A1 using bolts B1 with spring washers B4 & flat washers B5 .

### Step 3:

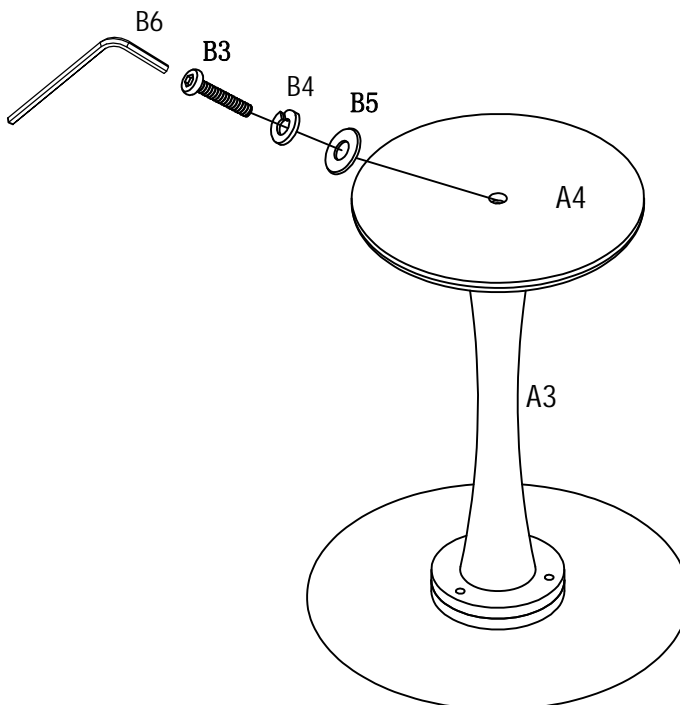

B3:  1pc

B4:  1pc

B5:  1pc

B6:  1pc

Assemble the base A4 to support bar A3 using bolt B3 with spring washer B4 & flat washer B5 .