

# Assembly Instructions

Style#: K112 Kitchen Cabinet

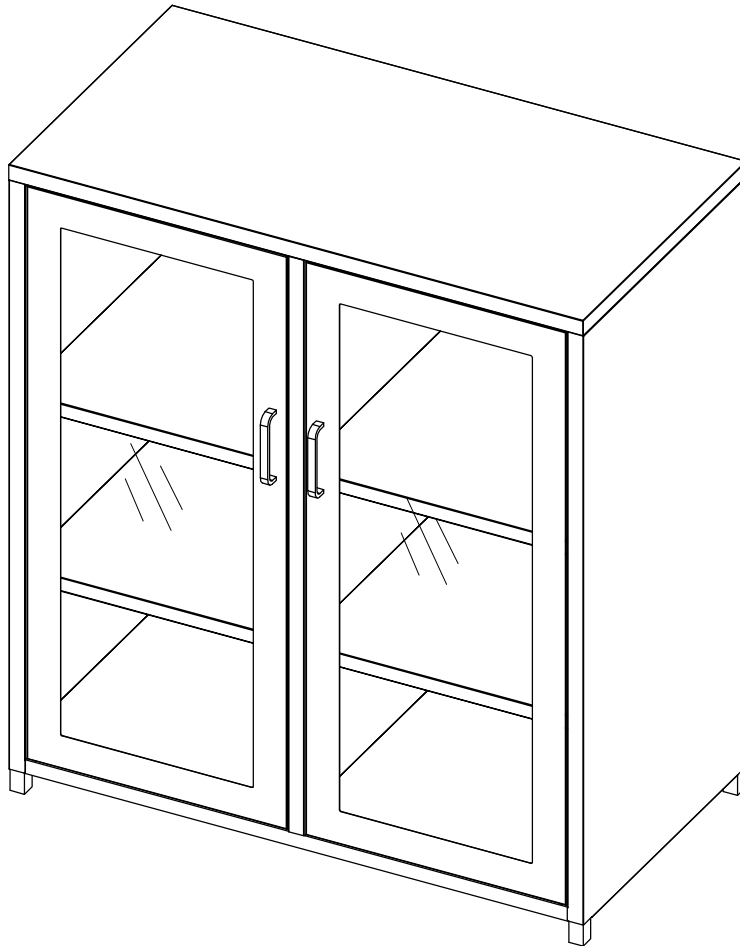

## NOTE TO CUSTOMERS:

- For ease and speed of assemble we recommend that before you commence each step of the assembly that you identify all the parts required to complete that step.
- We recommend that where possible you allow sufficient space to assemble the item as close as possible to the place where it will be once assembled.
- For the protection of your furniture we recommend that the product is placed on protected surfaces during assembly to prevent any damage.
- During assembly do not over tighten, as this may damage the product.
- Please ensure you retain all the product packaging until the item completely assembled.
- Please periodically check all fittings and re-tighten as necessary.
- It is recommended that this item should be assembled by two adults.

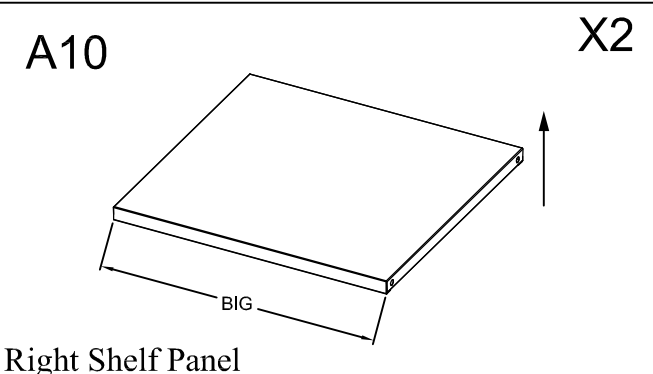
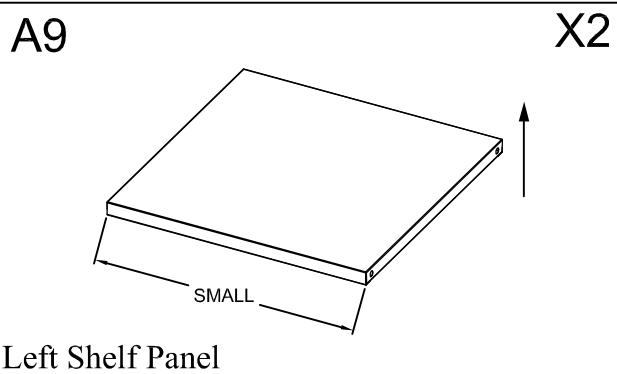
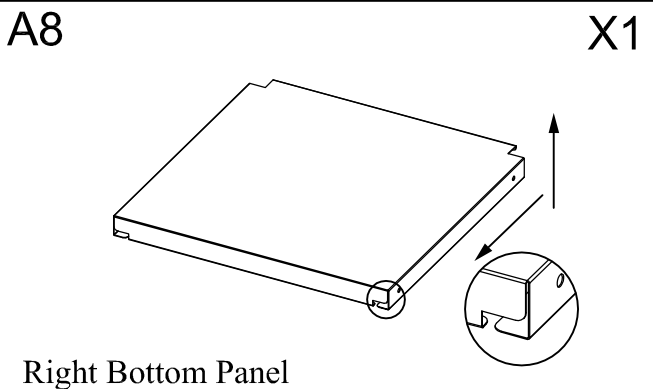
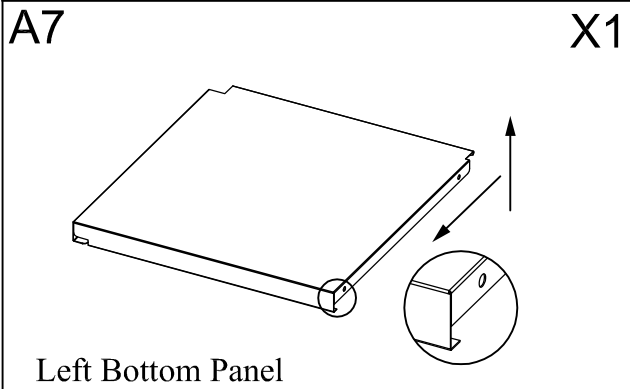
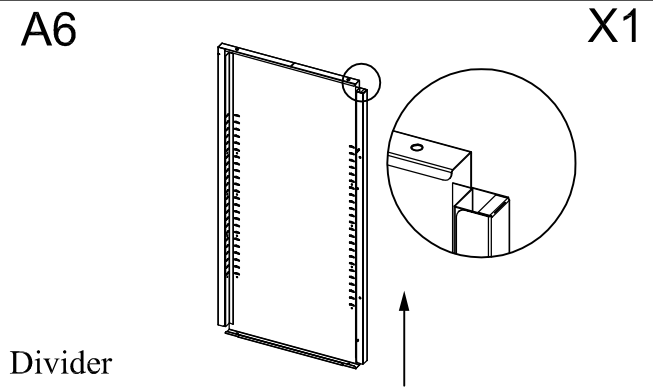
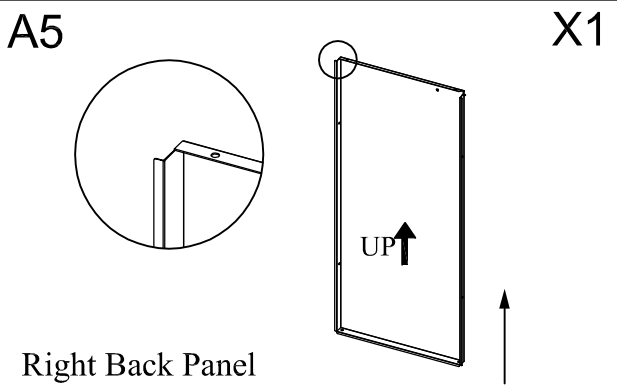
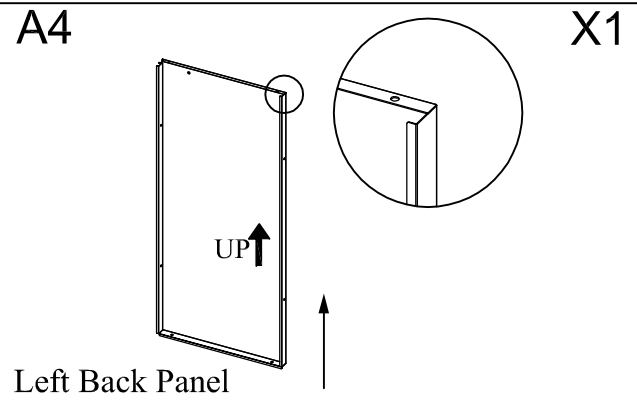
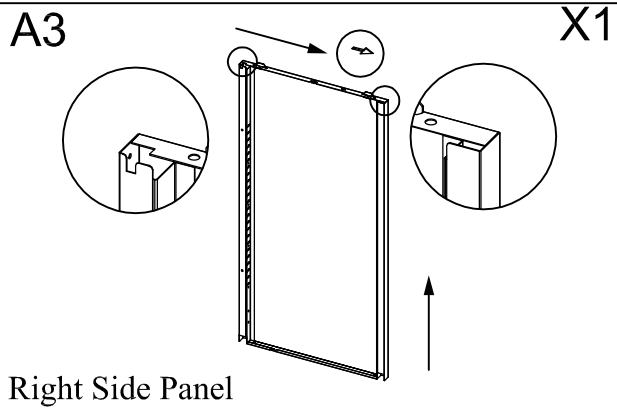
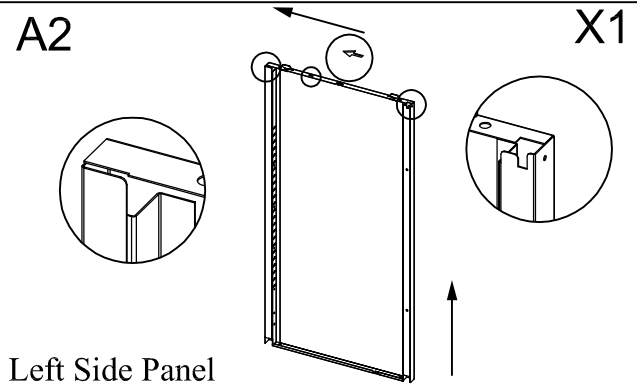
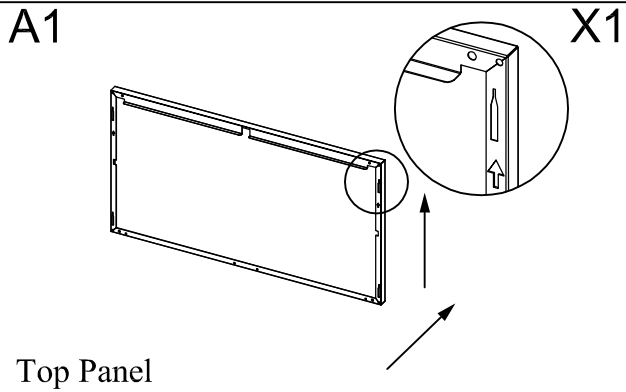

# Part List

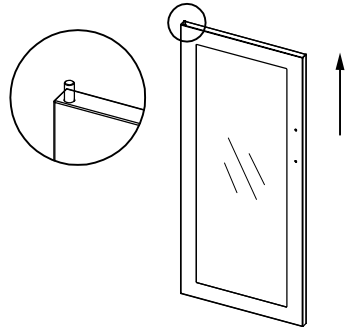
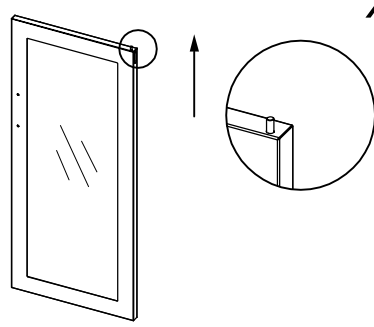
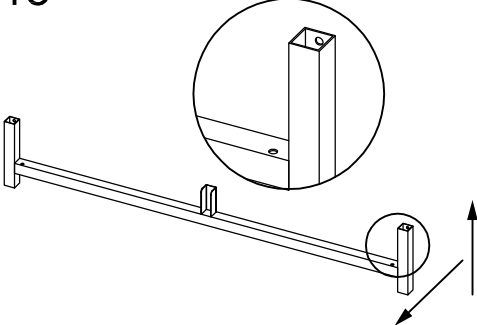

# Part List

<p><b>A11</b> <span style="float: right;"><b>X1</b></span></p>  <p>Left Door</p>	<p><b>A12</b> <span style="float: right;"><b>X1</b></span></p>  <p>Right Door</p>
<p><b>A13</b> <span style="float: right;"><b>X2</b></span></p>  <p>Connect Frame</p>	

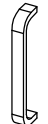
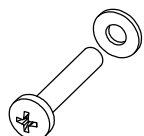
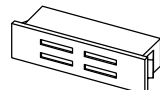
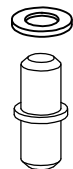
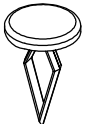
## Hardware list

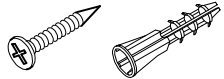
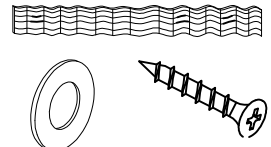
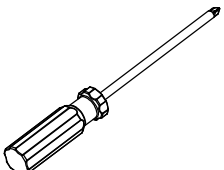
<p><b>B1</b> <span style="float: right;"><b>X2</b></span></p>  <p>Knob</p>	<p><b>B2</b> <span style="float: right;"><b>X4</b></span></p>  <p>Bolt with Washer</p>	<p><b>B3</b> <span style="float: right;"><b>X4</b></span></p>  <p>Magnet</p>	<p><b>B4</b> <span style="float: right;"><b>X2</b></span></p>  <p>Door Pin with Washer</p>
<p><b>B5</b> <span style="float: right;"><b>X16</b></span></p>  <p>Cap</p>	<p><b>B6</b> <span style="float: right;"><b>X16</b></span></p>  <p>Shelf Support</p>	<p><b>B7</b> <span style="float: right;"><b>X2</b></span></p>  <p>Anchor with screw</p>	<p><b>B8</b> <span style="float: right;"><b>X2</b></span></p>  <p>Anti-tip kit</p>
 <p>(Not included)</p>			

# Step 1

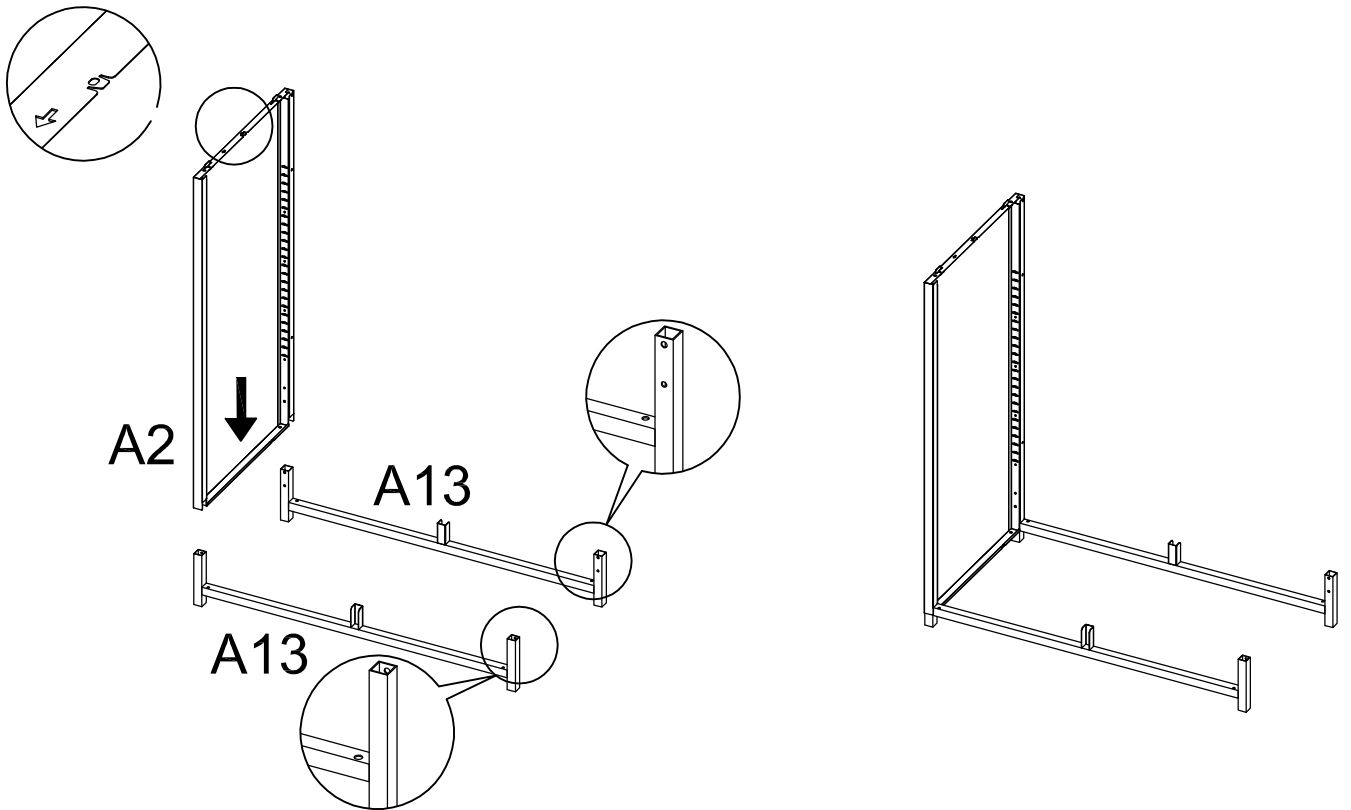

Insert Left Side Panel A2 into Connect Frames A13 as shown above.

# Step 2

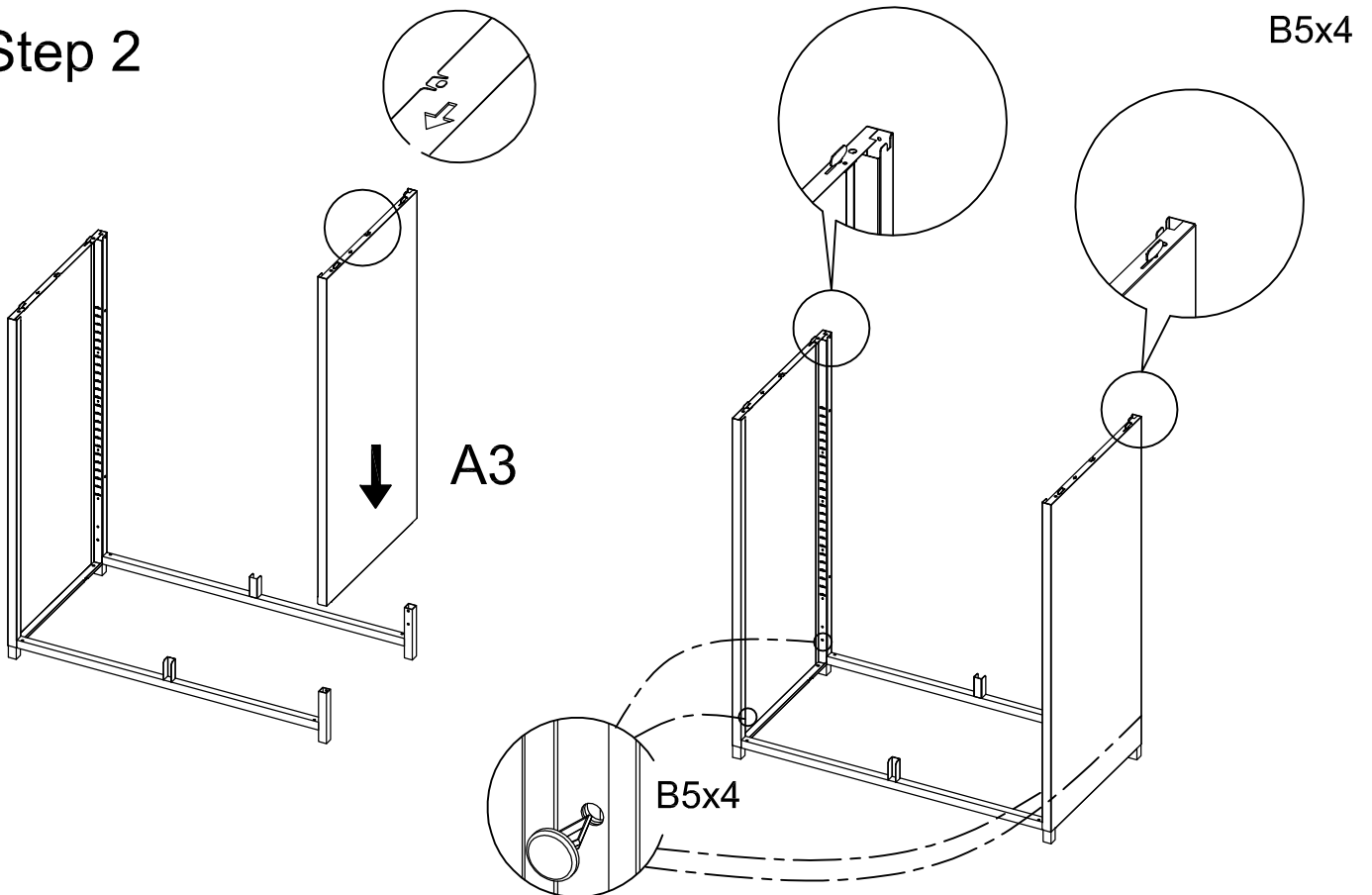

Insert Right Side Panel A3 into Connect Frames A13, then tighten them using Caps B5 as shown above.

## Step 3

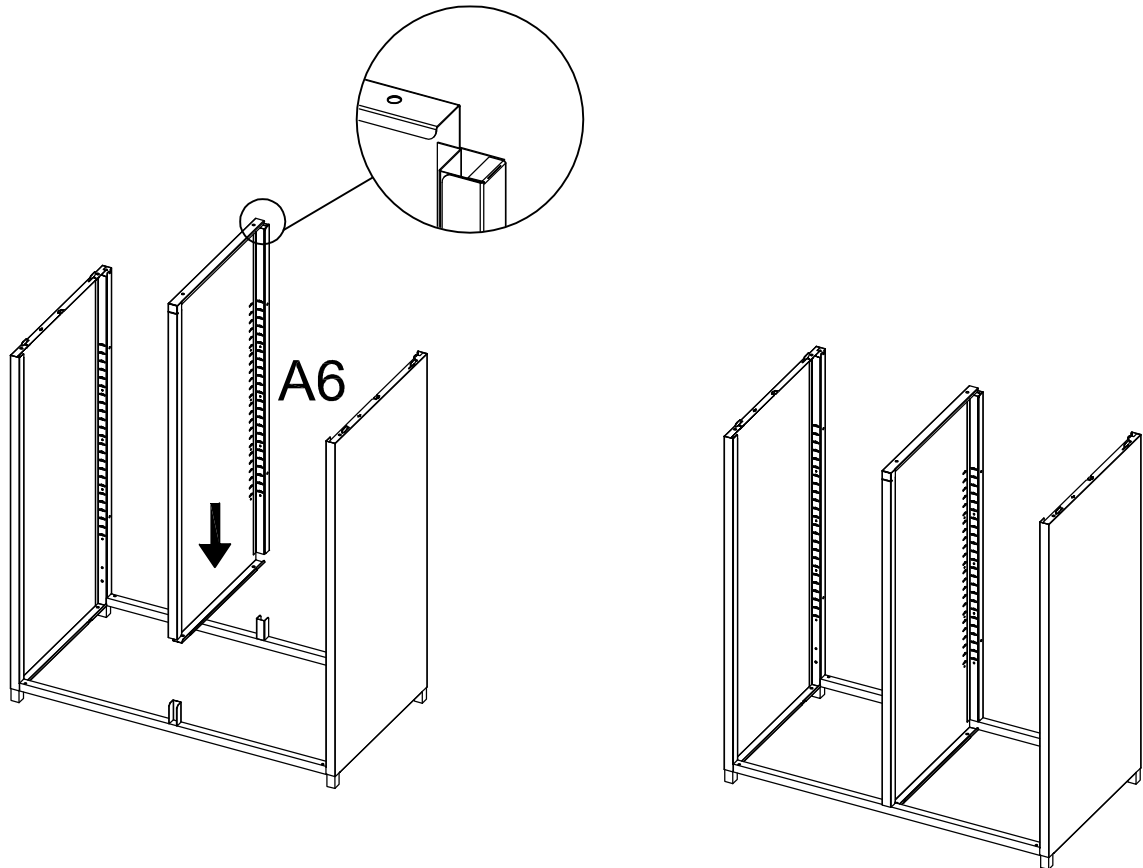

Insert Divider A6 into Connect Frames A13 as shown above.

## Step 4

B5x8

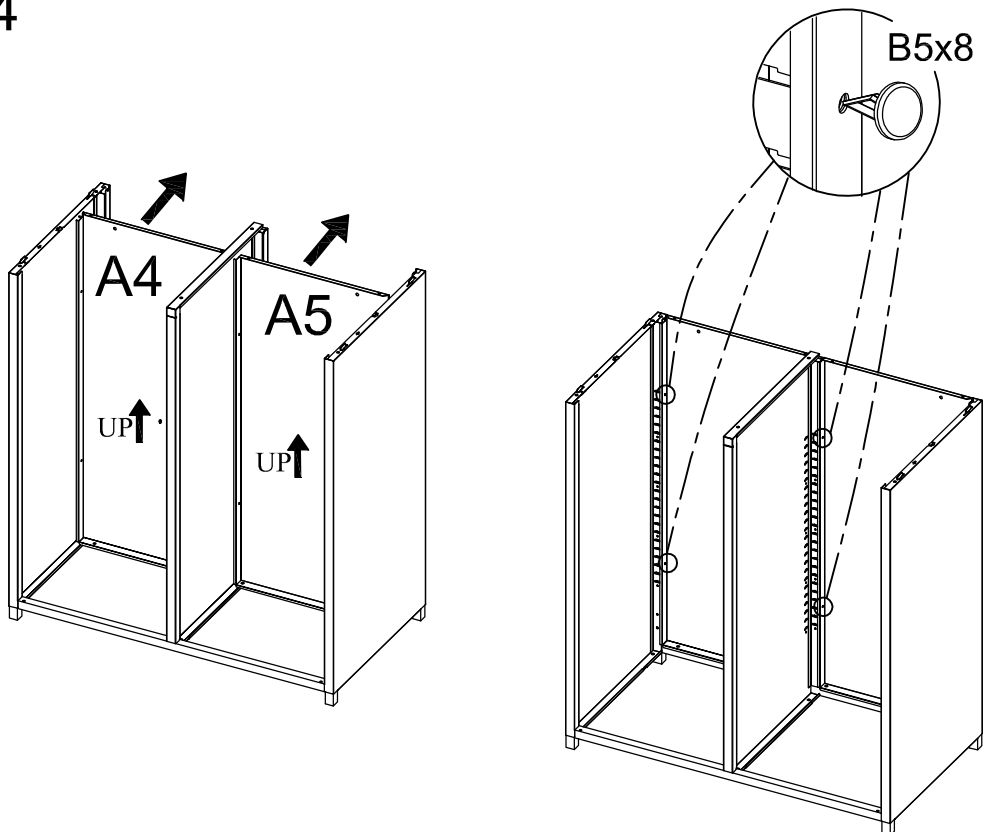

Assemble Back Panels A4&A5 (L&R) to Side Panels A2&A3 (L&R), Divider A6 and Connect Frame A13, then tighten them using Caps B5 as shown above.

## Step 5

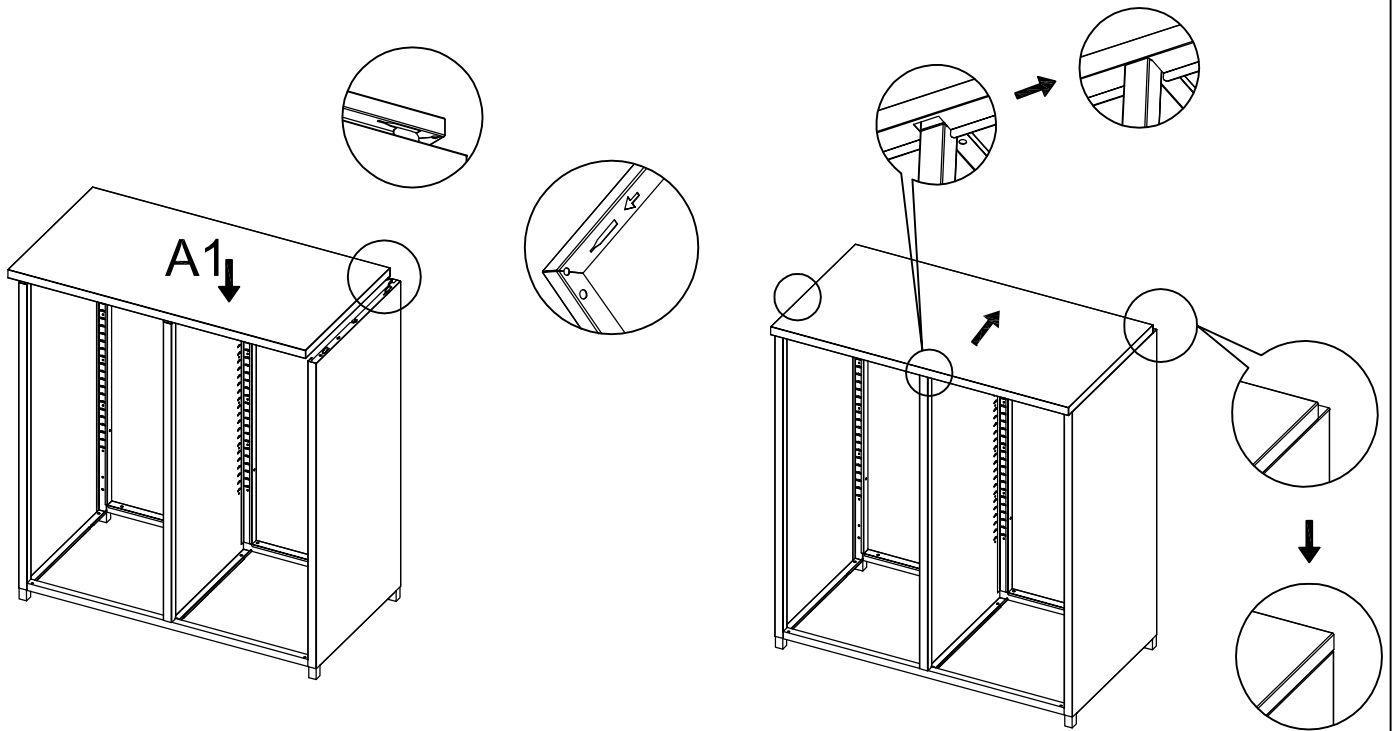

Attach Top Panel A1 to Side Panels A2&A3 (L&R), Back Panels A4&A5 (L&R) and Divider A6 as shown above.

## Step 6

B5x4

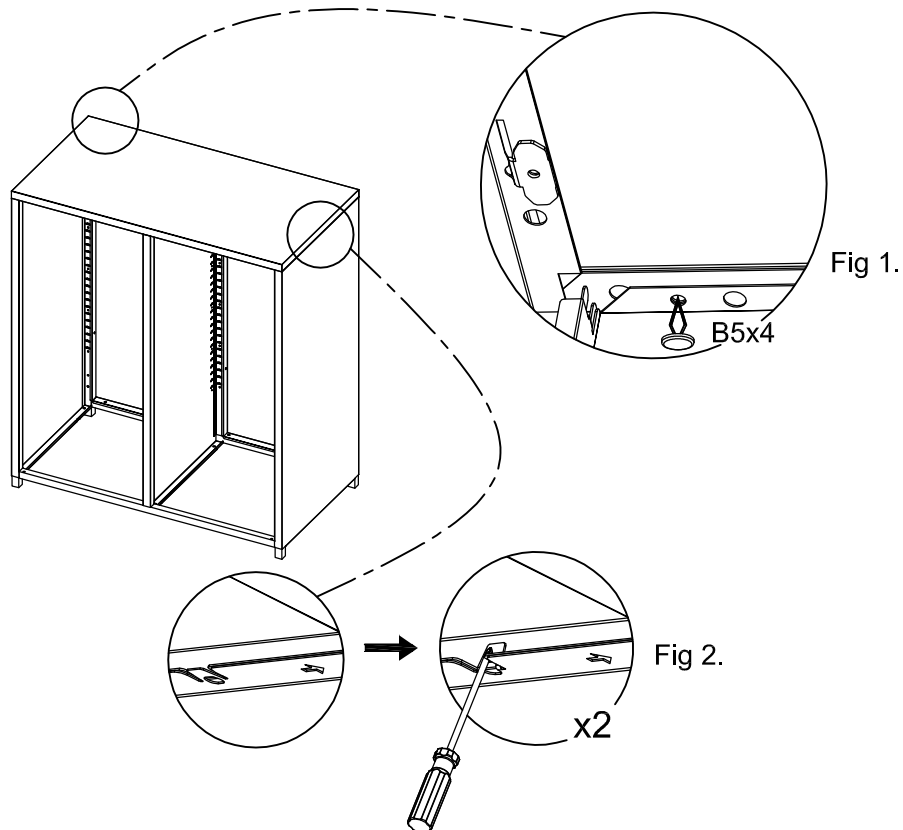

- 1). Tighten Top Panel A1 to Back Panels A4&A5 (L&R) using Caps B5, refer to Fig 1.
- 2). Tighten Top Panel A1 to Side Panels A2&A3 (L&R) by folding the metal plates, refer to Fig 2.

## Step 7

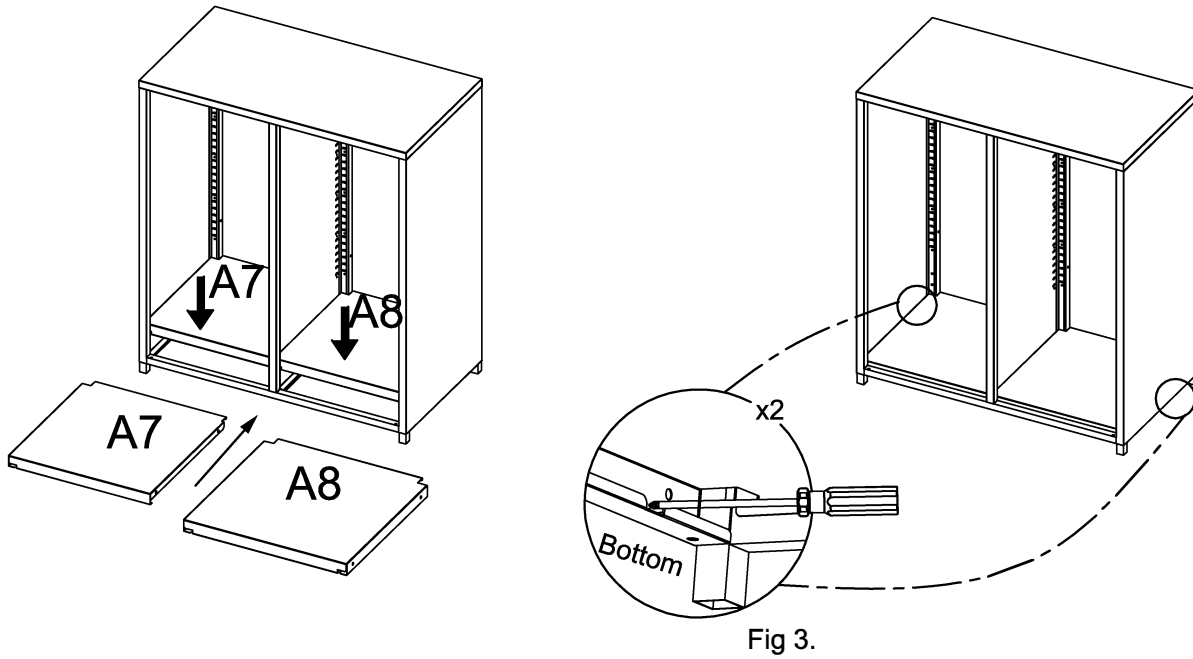

Insert Bottom Panels A7 & A8 (L&R) into the unit, then place the unit down on the floor carefully and tighten Bottom Panels A7&A8 (L&R) to Side Panels A2&A3 (L&R) by folding the metal plates, refer to Fig 3.

## Step 8

B6x16

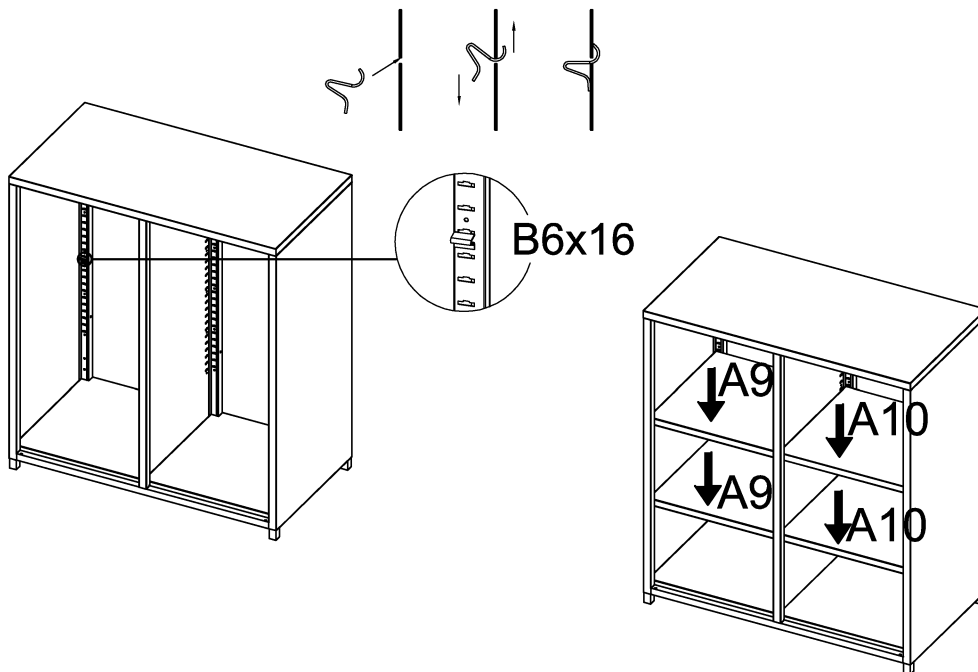

Attach Hooks B6 to Side Panels A2&A3 and Divider A6 as shown above, then place Shelf Panels A9&A10 into the unit.

## Step 9

B1x2

B2x4

B3x4

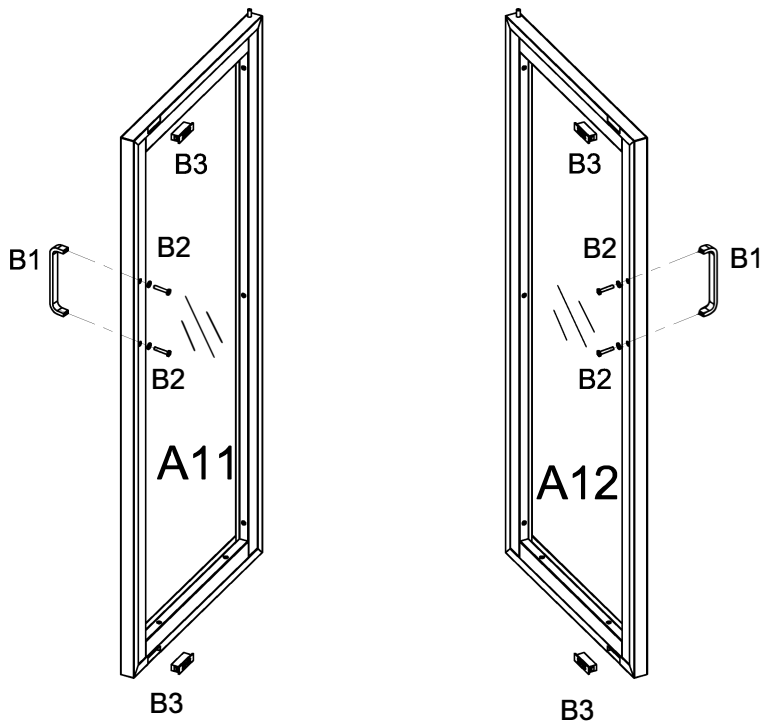

- 1). Attach Knobs B1 to Doors A11 & A12 using Bolts B2 with washers.
- 2). Insert Magnets B3 into Doors A11 & A12.

## Step 10

B4x2

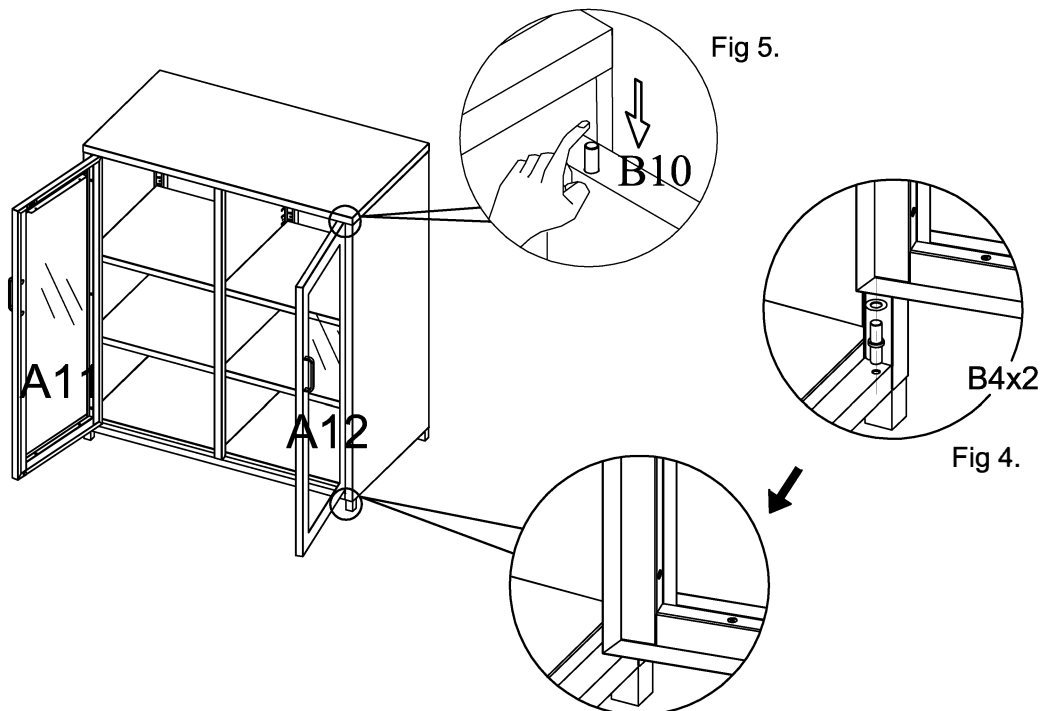

- 1). Assemble Door A12 to Connect Frame A13 using Door Pin and washer B4, refer to Fig 4.
- 2). Press down the pin on top of Door A12, refer to Fig 5. then place the door panel carefully into the cabinet with the door pin popping up into the hole of Top Panel A1.
- 3). Repeat the above steps to assemble the other door.



