

ASSEMBLY INSTRUCTIONS

Style # K111 Kitchen Cabinet

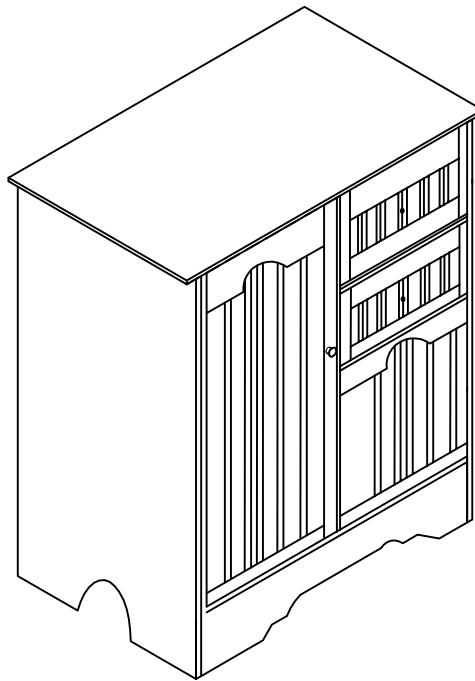

NOTE TO CUSTOMERS:

- For ease and speed of assembly we recommend that before you commence each step of the assembly that you identify all the parts required to complete that step.
- We recommend that where possible you allow sufficient space to assemble the item as close as possible to the place where it will be once assembled.
- For the protection of your furniture we recommend that the product is placed on protected surfaces during assembly to prevent any damage.
- During assembly do not over tighten, as this may damage the product.
- Please ensure you retain all the product packaging until the item completely assembled.
- Please periodically check all fittings and re-tighten as necessary.
- Please never allow any liquids to remain on your furniture as absorption can cause the wood to warp or finish to de-laminate.
- It is recommended that this item should be assembled by two adults.

To insert a cam lock: (Please read below instructions before assembling)

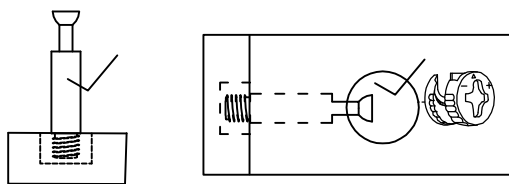

1. Insert cam screw into hole as shown in diagram A .

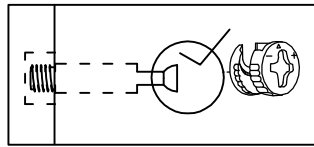

Diagram B

Make sure not to insert the cam screw:
Too deep as shown in figure B as this will cause the cam screw to be misaligned and unable to interlock properly.

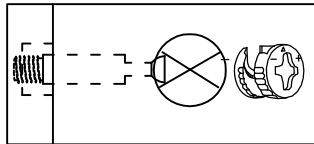
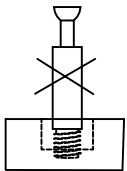
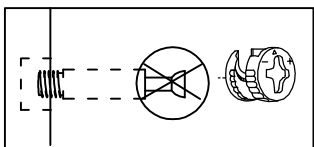
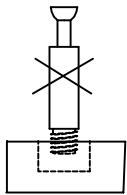
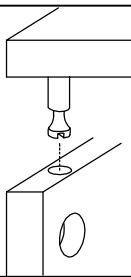

Diagram C

Also avoid inserting the cam screw too close to the surface of the hole as shown in figure C, as this will cause the cam lock to be too loose, and not interlock properly.



2. Connect the panels together.



3. When inserting the cam lock make sure the arrow of the cam lock faces the cam screw.

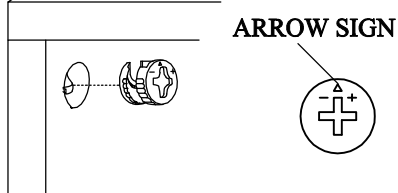

4. To tighten the cam lock turn the cam lock clockwise 90-180 degree or until the arrow is facing opposite the place cam lock was inserted.

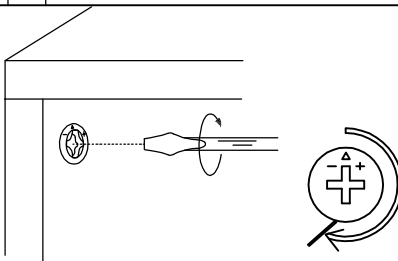



NOTE: DO NOT USE AN AUTOMATIC SCREWDRIVER TO TIGHTEN CAM LOCKS.





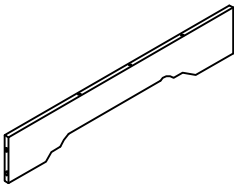
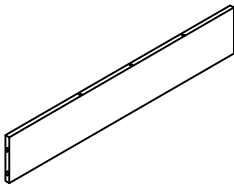
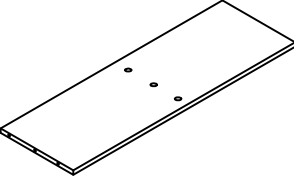
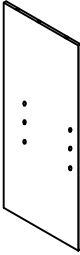
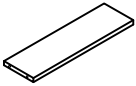

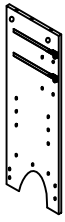
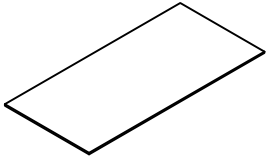
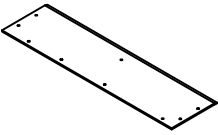
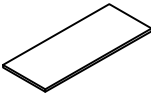
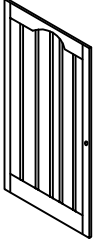
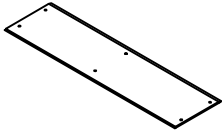
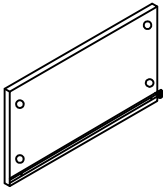
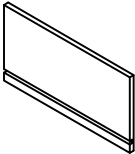
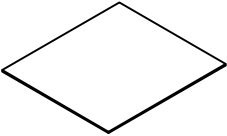
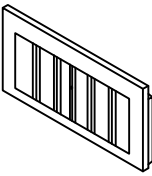
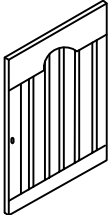
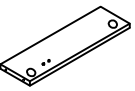
Note:

- Read these instructions carefully before assembling.
- Tools required : Phillips screwdriver, flat screwdriver.
- Find a clean, smooth area on which to work , such as a carpet, in order to avoid scratching the wood surfaces.
- Wait to dispose of the packing material until assembly is complete and all parts and hardware are accounted for.
- Two or more people might be required for assembly.

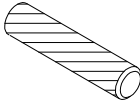
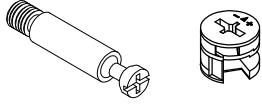
Part List

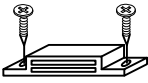
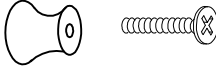

<p>A1. Quantity of 1</p>  <p>Front Apron</p>	<p>A2. Quantity of 1</p>  <p>Back Apron</p>	<p>A3. Quantity of 1</p>  <p>Bottom Panel</p>	<p>A4. Quantity of 1</p>  <p>Divider</p>
<p>A5. Quantity of 1</p>  <p>Top Connect Panel</p>	<p>A6. Quantity of 1</p>  <p>Side Panel (left)</p>	<p>A7. Quantity of 1</p>  <p>Side Panel (right)</p>	<p>A8. Quantity of 1</p>  <p>Top Panel</p>
<p>A9. Quantity of 2</p>  <p>Back Panel</p>	<p>A10. Quantity of 2</p>  <p>Shelf</p>	<p>A11. Quantity of 1</p>  <p>Large Door</p>	<p>A12. Quantity of 1</p>  <p>Center Back Panel</p>
<p>A13. (L, R) Quantity of 4</p>  <p>Drawer Side Panel</p>	<p>A14. Quantity of 2</p>  <p>Drawer Back Panel</p>	<p>A15. Quantity of 2</p>  <p>Drawer Bottom Panel</p>	<p>A16. Quantity of 2</p>  <p>Drawer Front Panel</p>
<p>A17. Quantity of 1</p>  <p>Small Door</p>	<p>A18. Quantity of 1</p>  <p>Middle Connect Panel</p>		

Hardware List

<p>B1. Quantity of 16</p>  <p>Wood Dowel</p>	<p>B2. Quantity of 24</p>  <p>Camlock</p>	<p>B3. Quantity of 22</p>  <p>Screw</p>	<p>B4. Quantity of 8</p>  <p>Shelf Support</p>
<p>B5. Quantity of 8</p>  <p>Screw</p>	<p>B6. Quantity of 2</p>  <p>Magnet</p>	<p>B7. Quantity of 4</p>  <p>Knob with Bolt</p>	<p>B8. Quantity of 16</p>  <p>Screw</p>

STEP 1

Assembly Instructions

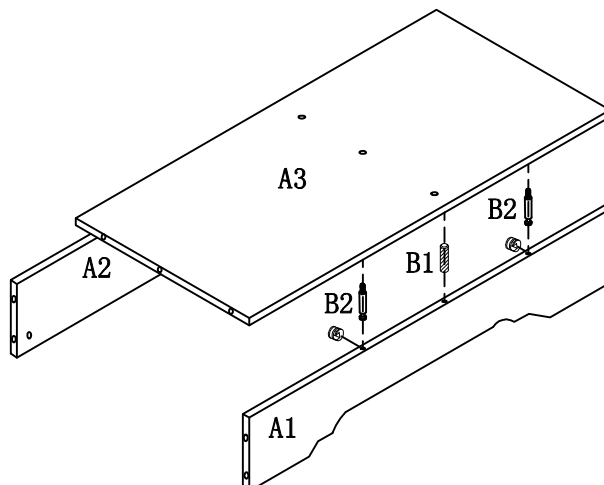

B1		2pcs
B2		4sets

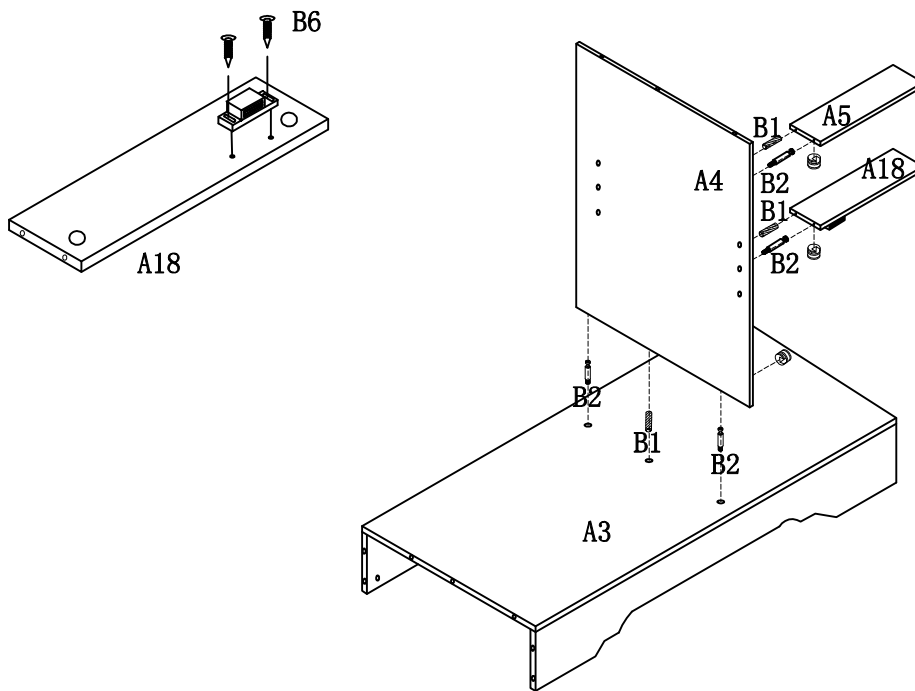

Assemble Front Apron A1 and Back Apron A2 to Bottom Panel A3 using Camlocks B2 and Wood Dowels B1.

STEP 2





B1		3pcs
B2		4sets
B6		1set

- 1), Attach Magnet B6 to Middle Connect Panel A18 by included screws.
- 2), Assemble Top Connect Panel A5 and Middle Connect Panel A18 to Divider A4 using Camlocks B2 and Wood Dowels B1.
- 3), Assemble Dividers A4 to Bottom Panel A4 using Camlocks B2 and Wood Dowels B1.

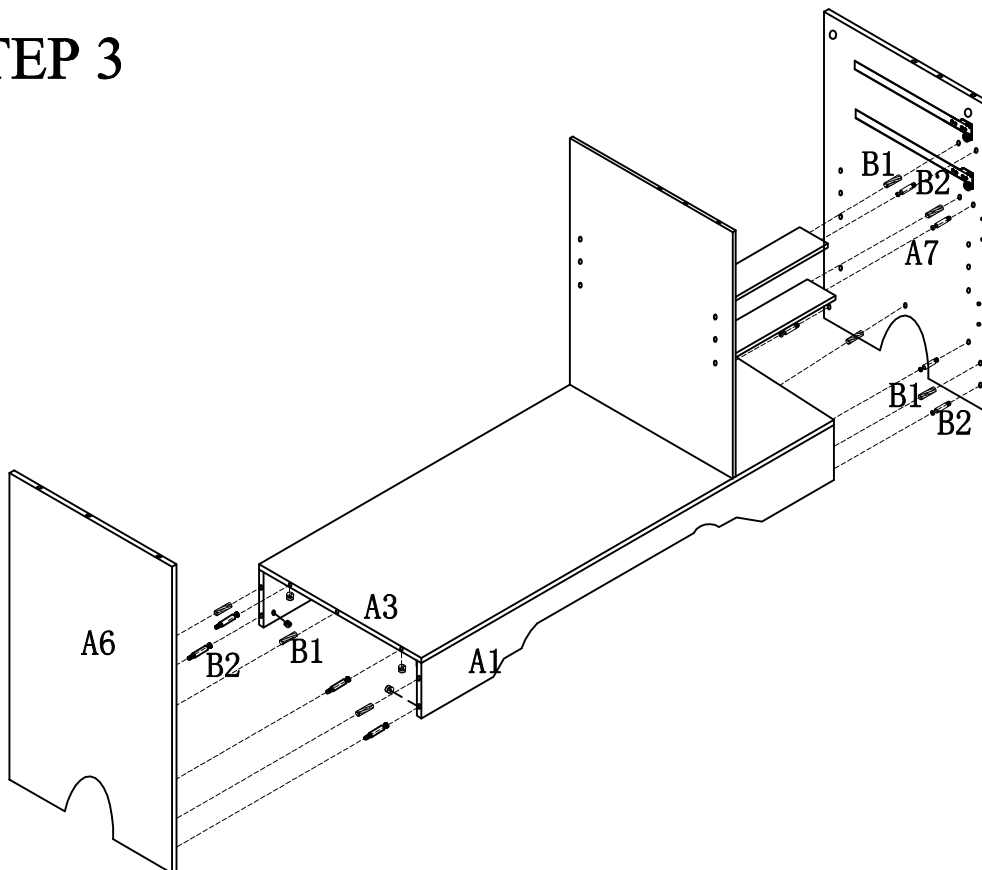
STEP 3



B1		8pcs
B2		10sets

- 1), Assemble Side Panel A7 to Top Connect Panel A5 , Middle Connect Panel A18 ,Bottom Panel A3 , Back Apron A2 and Front Apron A1 using Camlocks B2 and Wood Dowels B1.
- 2), Assemble Side Panel A6 to Bottom Panel A3 , Back Apron A2 and Front Apron A1 using Camlocks B2 and Wood Dowels B1.

STEP 4

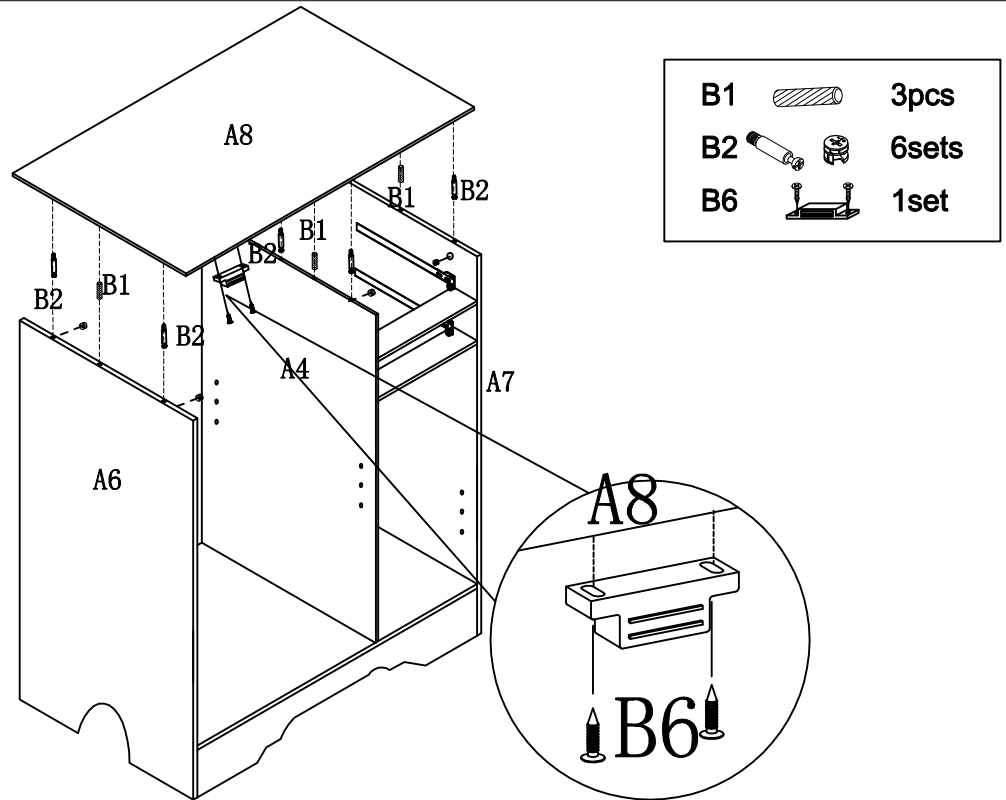

- 1), Attach Magnet B6 to the bottom of Top Panel A8 by included screws.
- 2), Assemble Top Panel to Side Panels A6/A7 and Divider A4 using Camlocks B2 and Wood Dowels B1.



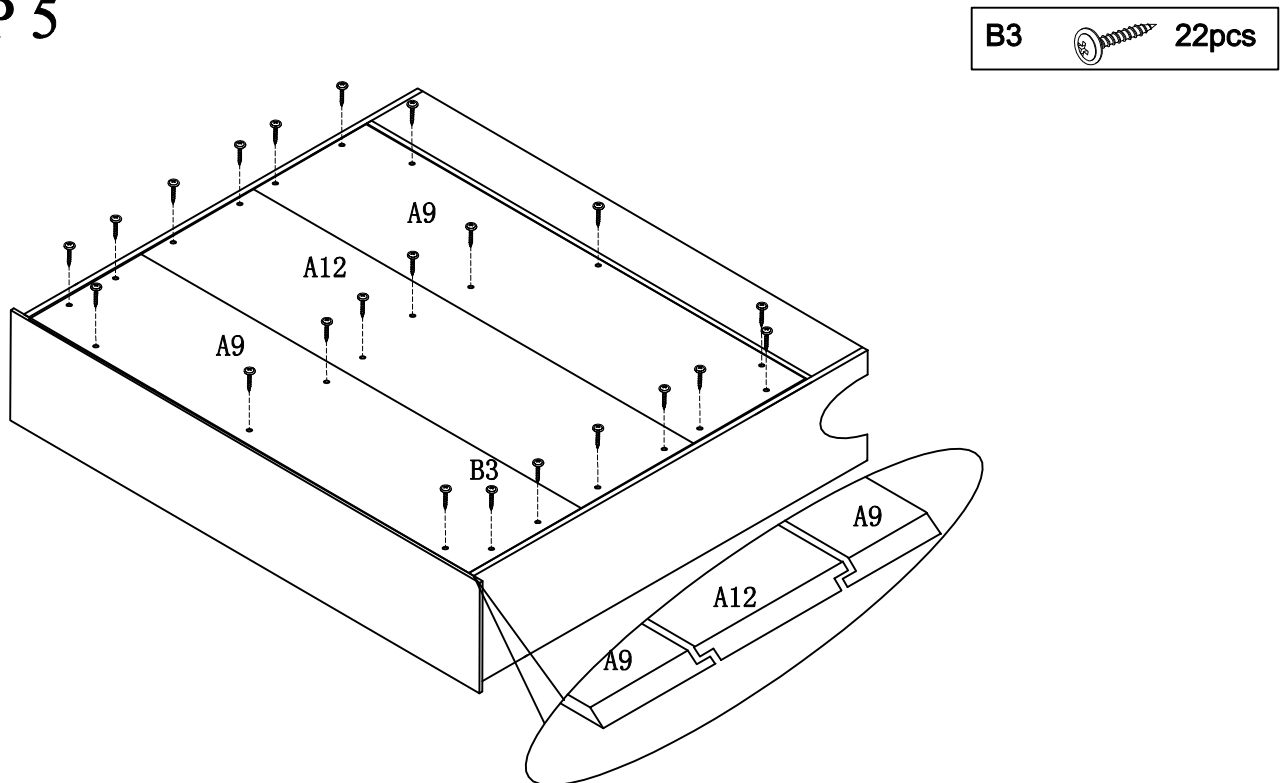

STEP 5

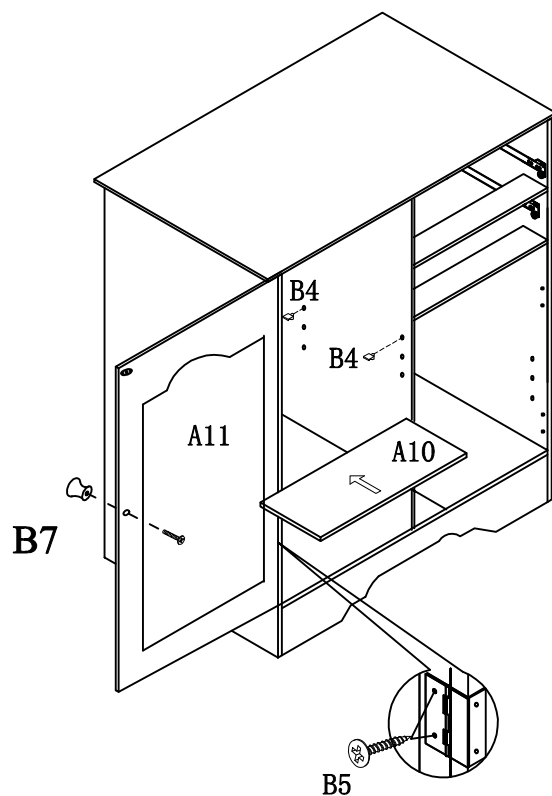

1. First place Back Panels A9, then place Center Back Panel A12 as shown above.
2. Tighten Back Panels A9 and Center Back Panel A12 to unit using Screws B3.

STEP 6



B4		4pcs
B5		4pcs
B7	 	1set

- 1), Attach Knob B7 to Door A11 with included bolt. Then assemble Door Panel A11 to Left Side Panel A6 using screws B5.
- 2), Insert Shelf Supports B4 into holes on Left Side Panel A6 and Divider A4, then put Shelf A10 onto Shelf Supports B4.

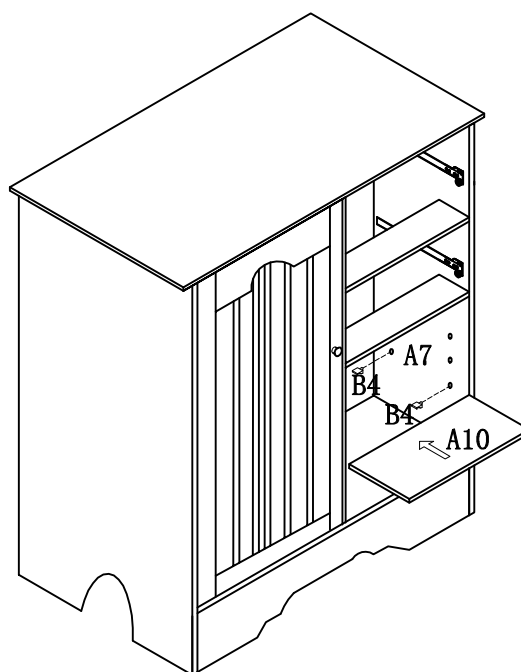

STEP 7



B4		4pcs
----	---	------

Insert Shelf Supports B4 into holes on Right Side Panel A7 and Divider A4, then put Shelf A10 onto Shelf Supports B4.

STEP 8

B8		16pcs
B7		2set

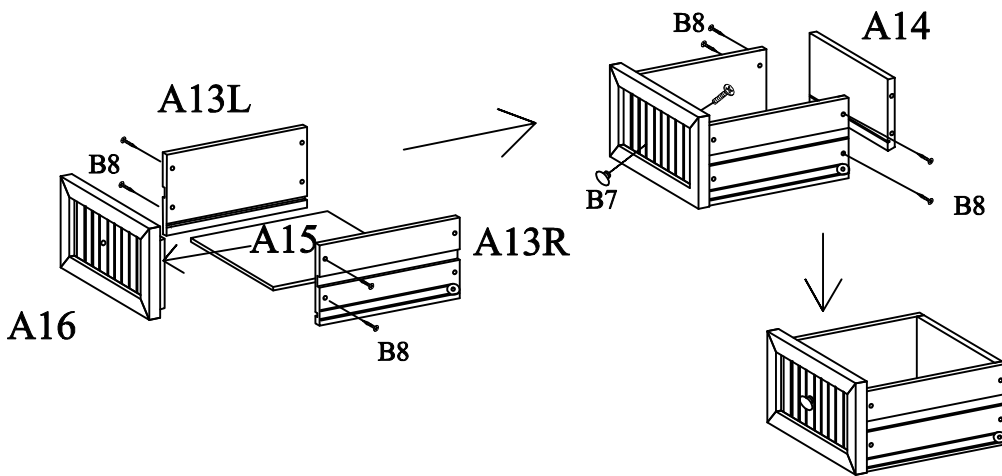

X2

- 1). Insert Drawer Bottom Panel A15 into the groove on Drawer Front Panel A16.
- 2). Attach Drawer Side Panels A13(L&R) to Drawer Front Panel A16 using Screws B8, please ensure the grooves on the Drawer Side Panels A13(L&R) face inside of drawer.
- 3). Attach Drawer Back Panel A14 to Drawer Side Panel A13(L&R) using Screws B8.
- 4). Attach Knob B7 to Drawer Front Panel A16 using included Bolt B7.

STEP 9

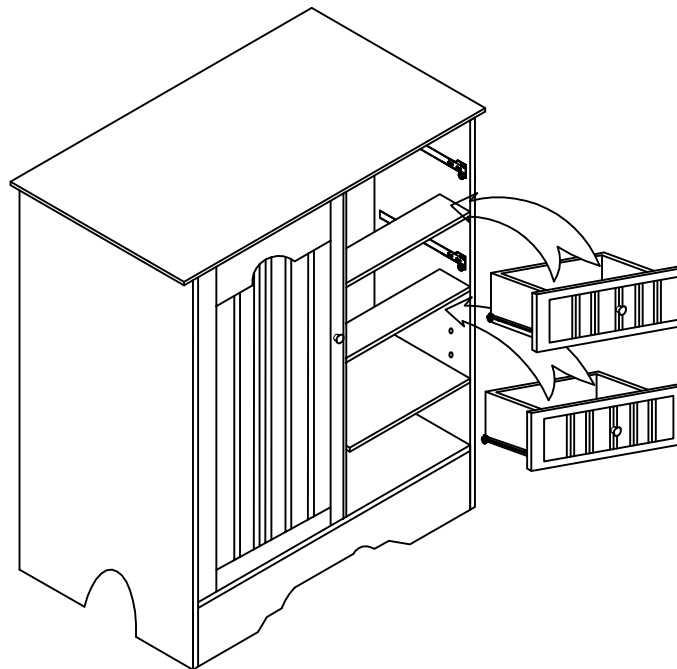

Insert Drawers as shown above.

STEP 10

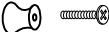
B5		4pcs
B7		1set

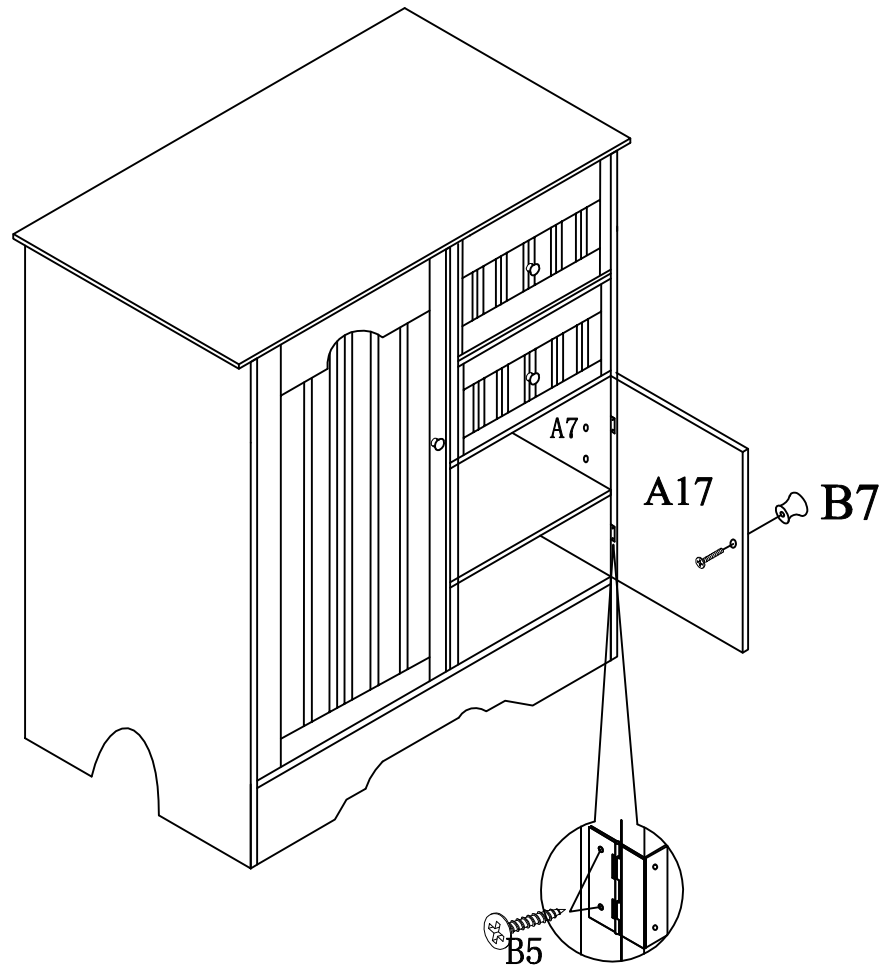

Attach Knob B7 to Door A17 by included bolt. Then assemble Door Panel A17 to Right Side Panel A7 using screws B5.

APPENDIX: Dimension of Hardwares in this AI.

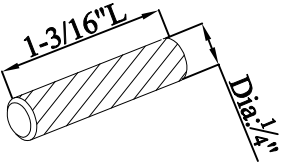
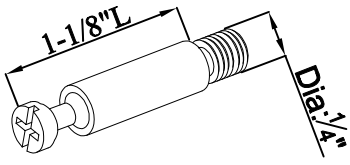
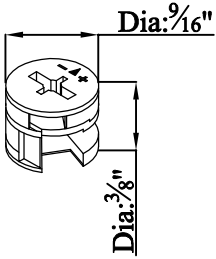
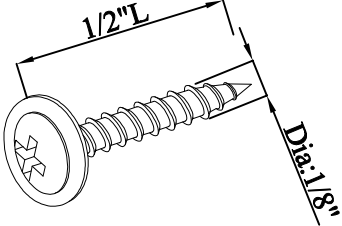
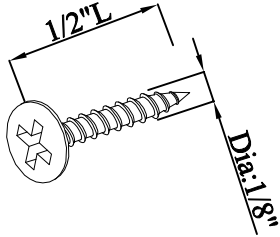
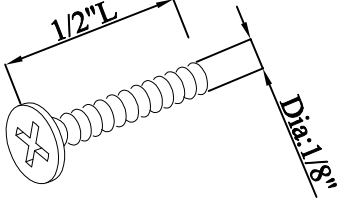
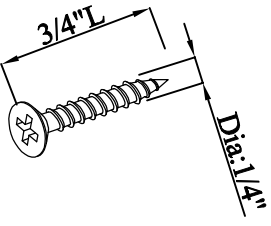
<p>B1.</p>  <p>Wood Dowel</p>	<p>B2.</p>   <p>Cam-bolt Cam-nut</p>	
<p>B3&B6.</p>  <p>Round Head Screw</p>	<p>B5.</p>  <p>Flat Head Screw</p>	<p>B7.</p>  <p>Bolt for Knob</p>
<p>B8.</p>  <p>Flat Head Screw</p>		