

Assembly Instruction

Model#D1022/D1023

Item Must Be Assembled By Two Adults.

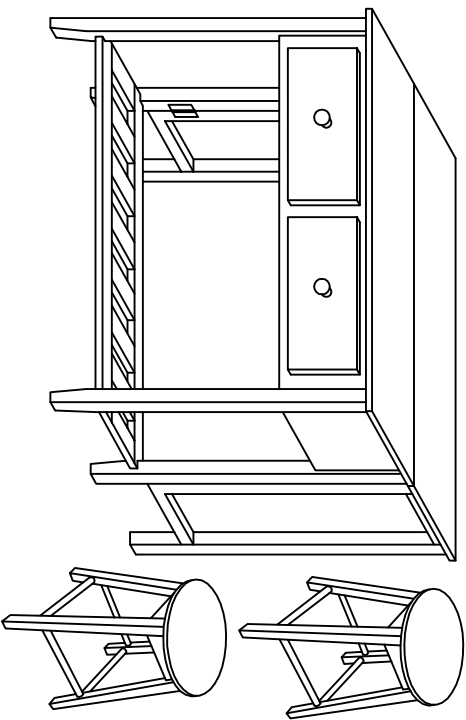

Tools Required



(Provided)

Allen key

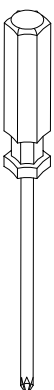

Phillips screwdriver

Hardware Provided



B1 24SETS



B2 4PCS



B3 16PCS



B4 9PCS

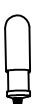

B5 1PC

Apply a little glue B5 into the wood dowel holes when inserting wood dowels.

Furniture Parts

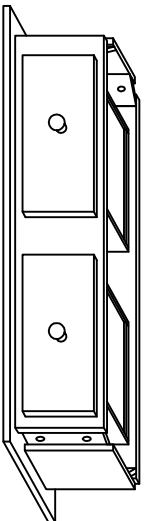

A1 1PC

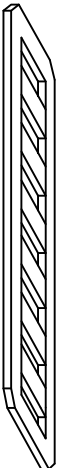

A2 1PC



A3 1PC

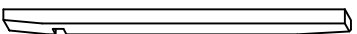

A4 2PCS

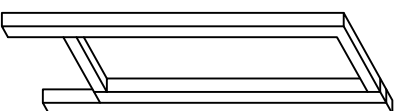

A5(L&R)2PCS

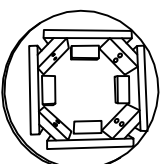

A6 2PCS

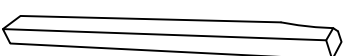

A7 4PCS

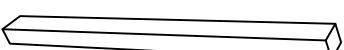

A8 4PCS

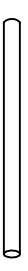

A9 8PCS

Step 1

Assemble the legs A4,A5(R&L) to the table top A1 with bolts and washers B1.

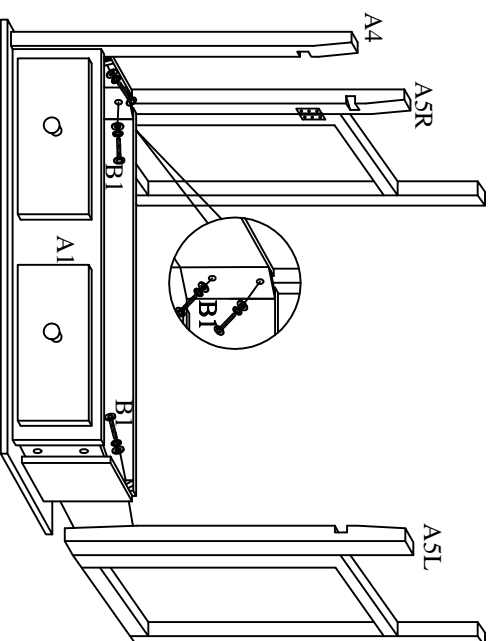

Step 2

Insert the bottom panel A2 into the grooves of the legs A4,A5(R&L)

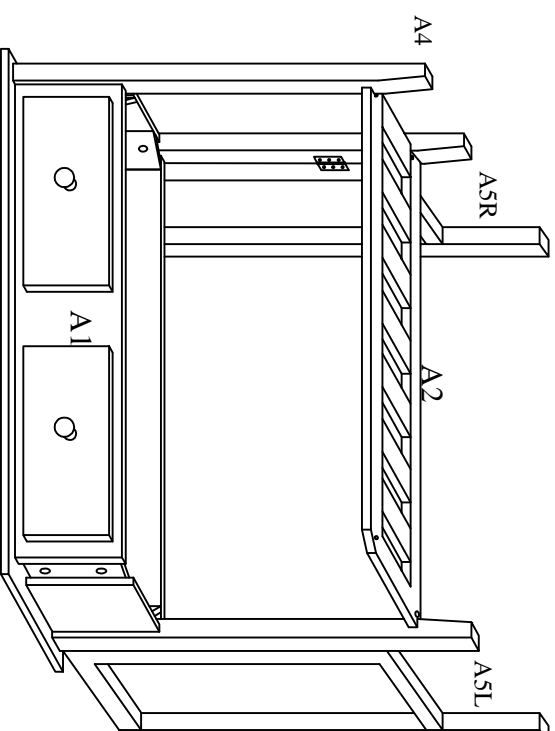

Step 3

Assemble the rest of the leg A4 to the table top A1 and bottom panel A2 with screws B2 and bolts & washers B1, then tighten the bottom panel A2 to the legs A4,A5(R&L) with screws B2.

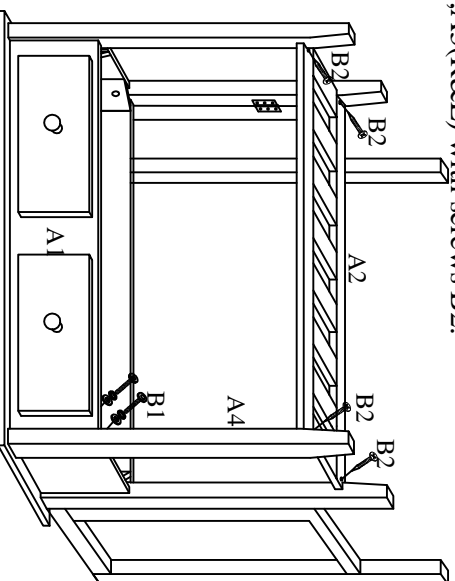

Step 4

Put the top panel A3 onto the legs A5(R&L) and tighten the top panel A3 to A1 with screws B4 from bottom.

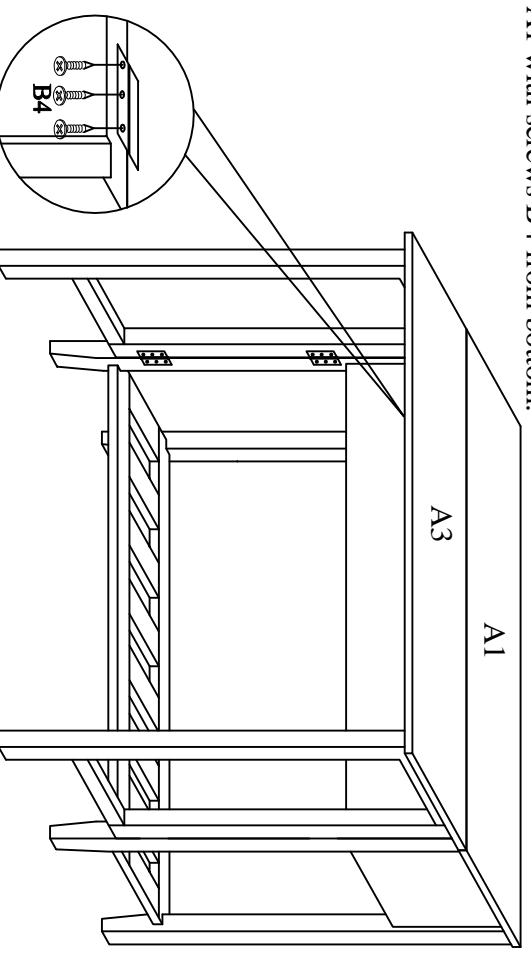

Step 5

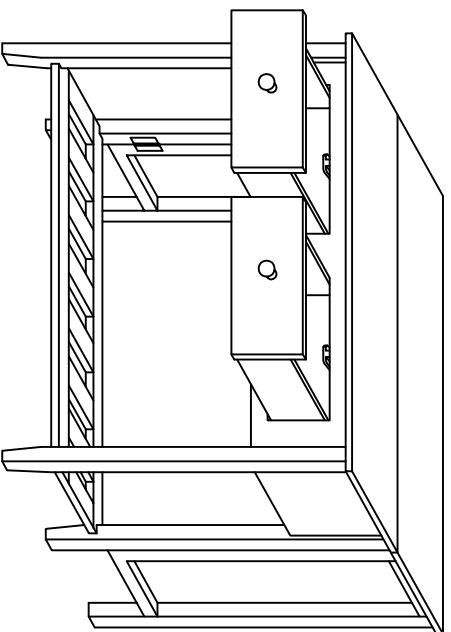

Step 6

Assemble the legs A7,A8 to the stool top A6 with bolts and washers B1.
Note:Please don't overtighten the bolts B1 on this assembly step.

Insert the wood bars A9 into the holes of legs A7andA8,thentighten the Cross bars A9 to the legs A7 &A8 with screws B3 from bottom.

Then tighten the bolts B1 on the above assembly step.

