

User's Manual
Style#B4006 Bunk Bed

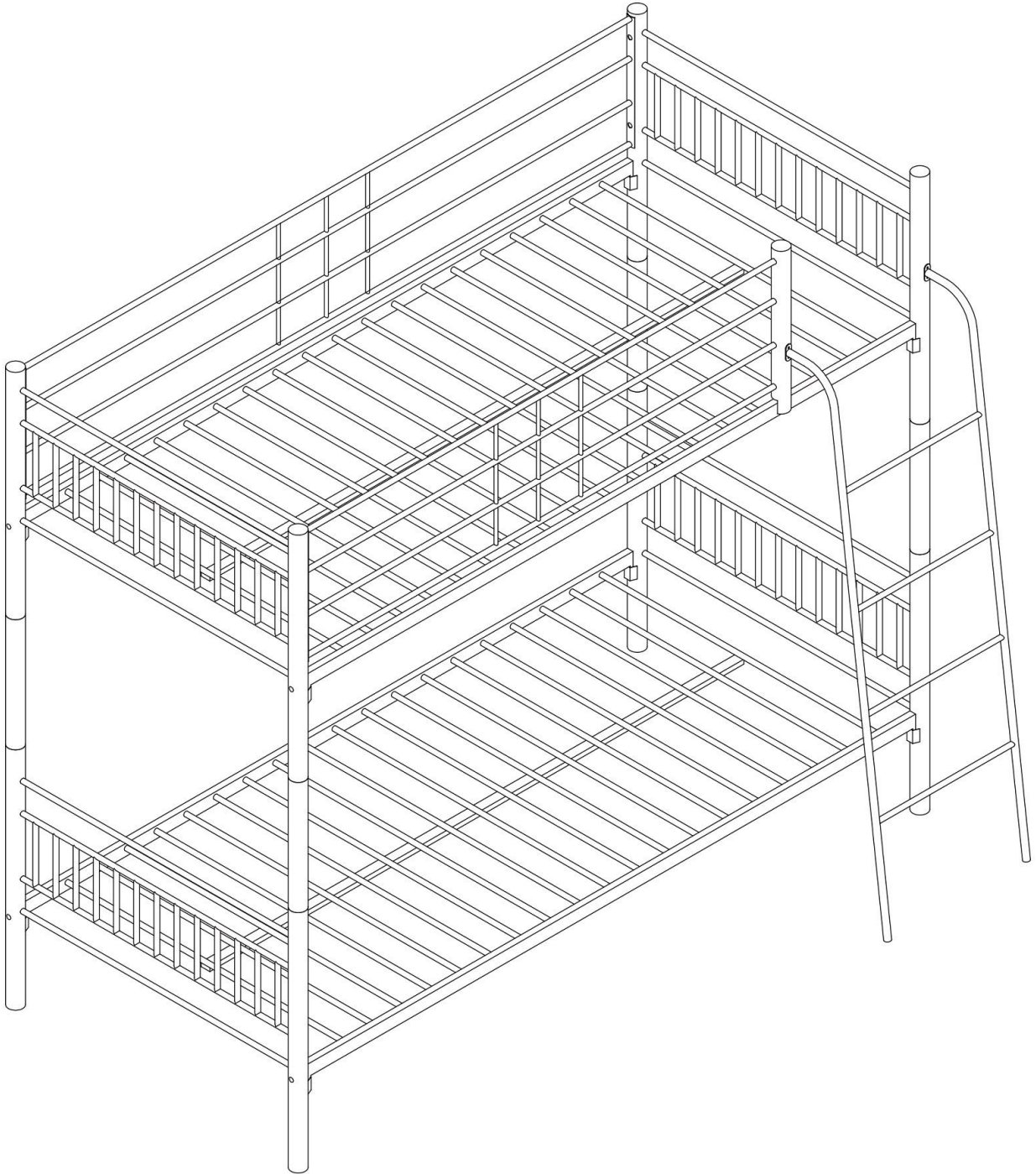

Dear Customer:

Thank you for selecting one of our bunk beds. Before assembling your bunk bed, please read this manual carefully.

IMPORTANT

- 1) Your bunk bed should be assembled in the room where it is to be used;
- 2) It is recommended to assemble your bunk bed on a pad in order to protect the finish;
- 3) It requires at least 3 persons to assemble your bunk bed;
- 4) Do not tighten the bolts and nuts until each part is in its assembled place.

WARNINGS

Follow the warnings appearing on one of the upper bunk bed end structures and on the carton.

DO NOT REMOVE WARNING LABEL FROM BED.

The mattress foundation is designed to support a mattress without the need for a posture board or box-spring.

Always use the recommended size mattress or mattress support, or mattress support, or both, to help prevent the likelihood of entrapment or falls.

Use only a mattress that is 74"-75" long and 37¹/₂"-38¹/₂" wide on either bunk.

Ensure thickness of mattress and foundation combined does not exceed 7".

Mattress surface must be at least 5" (127mm) below the upper edge of guardrails.

Do not allow children less than 6 years of age to use the upper bunk.

Periodically check and ensure that the guardrails, ladders and other components are in their proper position, free from damage, and that all connectors are tight.

Do not allow horseplay on or under the bed and prohibit jumping on the bed.

Always use the ladder for entering and leaving the upper bunk.

Do not use substitute parts. Contact your local dealer for replacement parts.

Use of a night light may provide added safety precaution for a child using the upper bunk.





Always use guardrails on both sides of the upper bunk.

Prohibit more than one person on upper bunk,



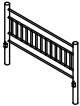

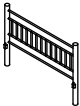

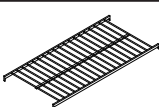
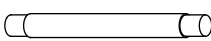
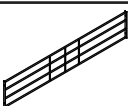
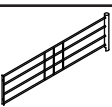
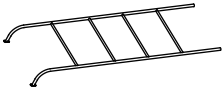



The use of water or sleep flotation mattress on this bed is prohibited.

PLEASE KEEP THIS MANUAL FOR YOUR FUTURE REFERENCE.

A-Furniture Parts

Parts ID	Image	Description	Qty
A		Lower Headboard	2
B		Upper Headboard	1
C		Upper Headboard	1
D		Top Platform	1
E		Bottom Platform	1
F		Connecting Post	4
G		Back Guardrail	1
H		Front Guardrail	1
I		Ladder	1

B-Hardware Parts

Parts ID	Image	Description	Qty
1		Bolt M8*90mm	8
2		Bolt M6*20mm	10
3		Bolt M6*65mm	1
4		Bolt M6*35mm	1
5		M8 Washers	8
6		M6 Washers	10
7		HB End cap	8
8		5# Allen Key	1
9		Screw-holecap	2
10		4# Allen Key	1

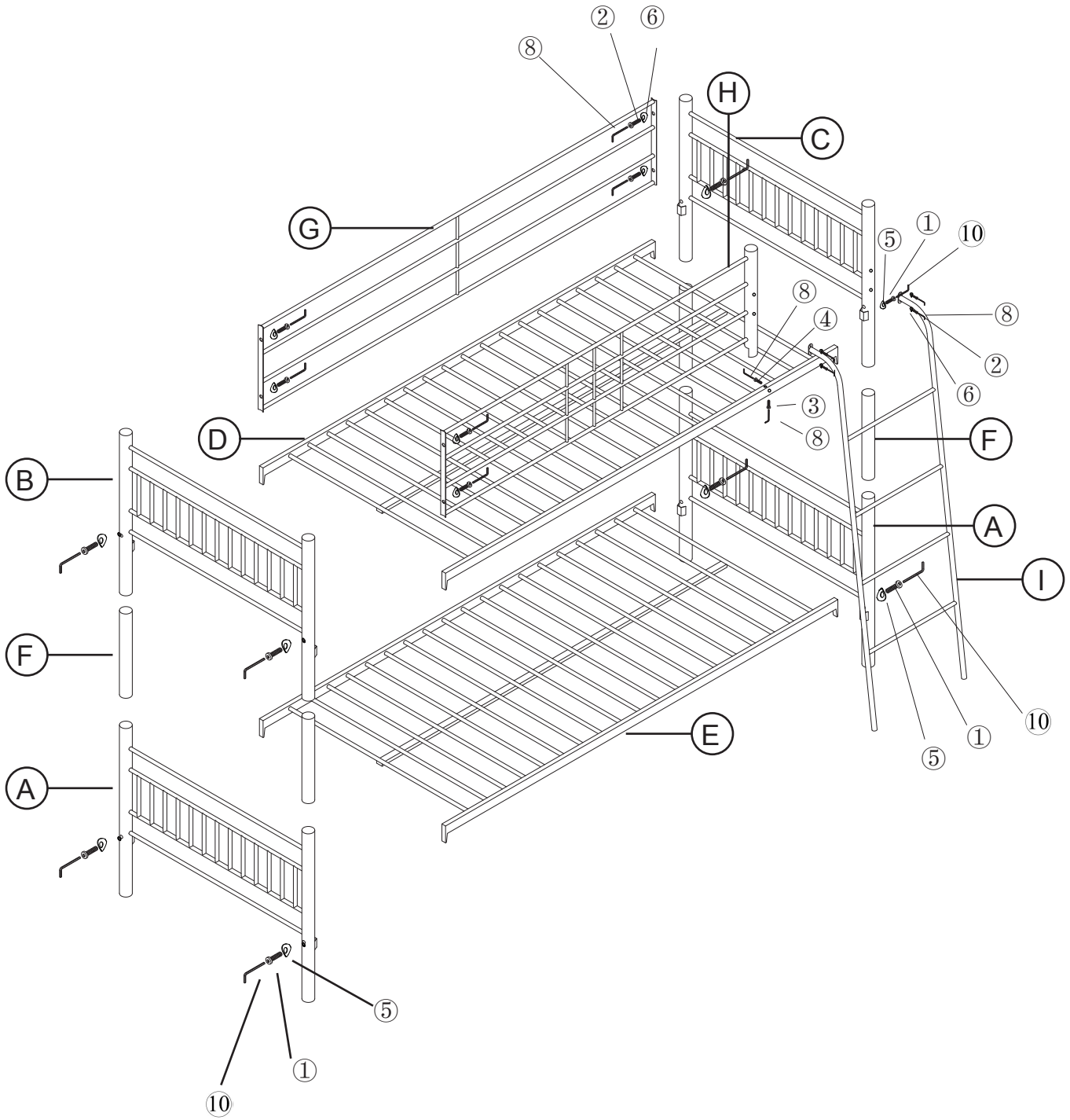

Step 1

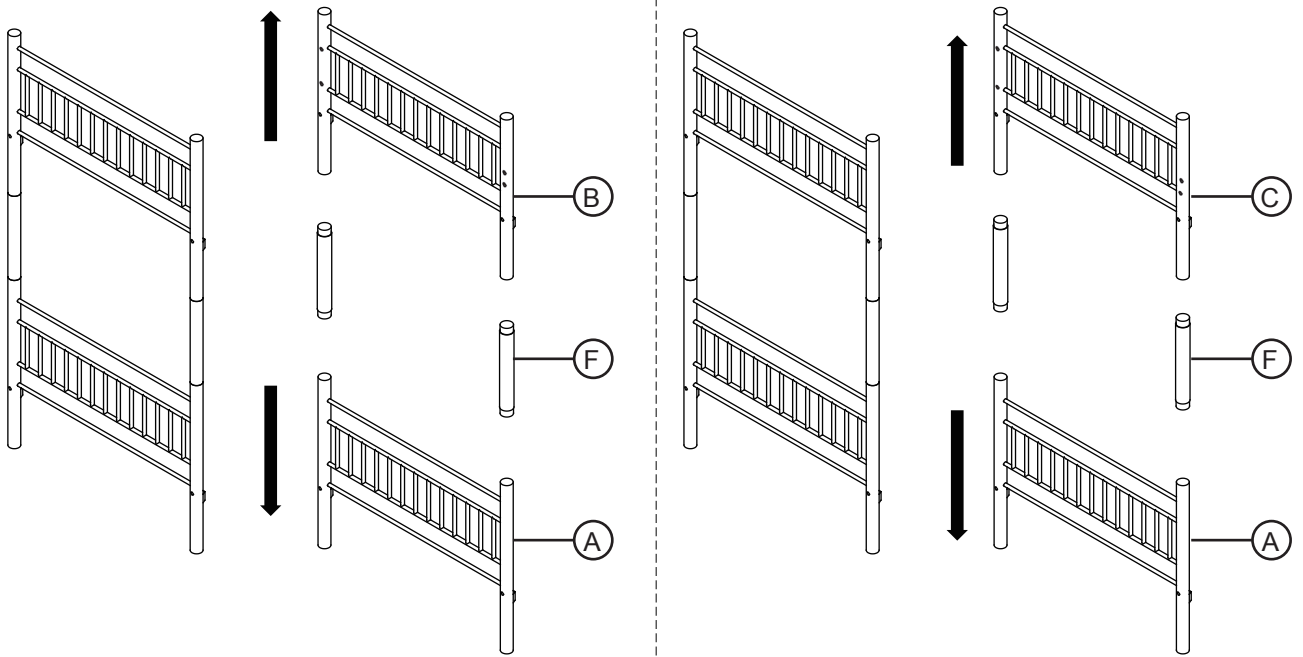

Split the bed frame into 3 parts as shown above.

Step 2

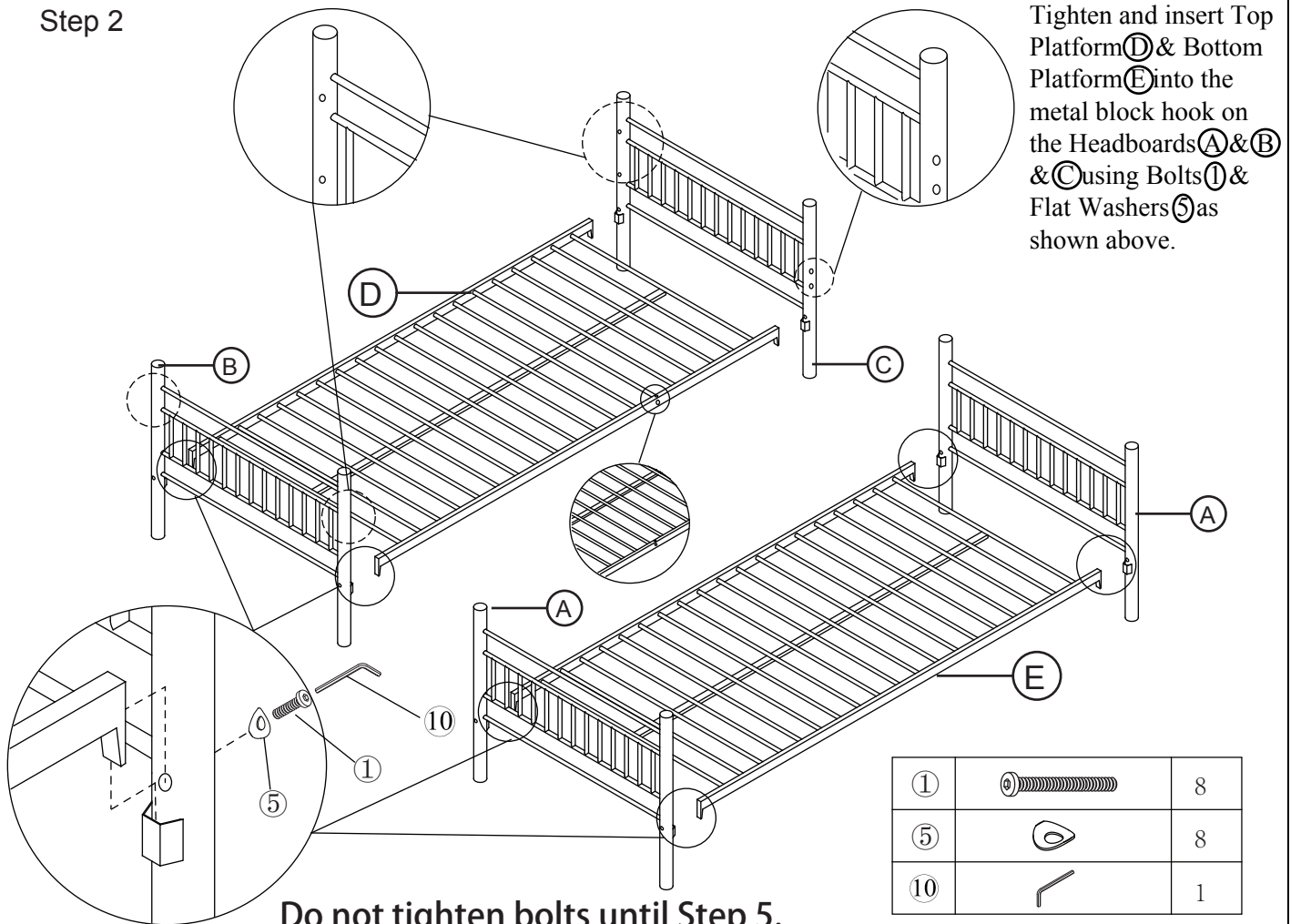

Step 3

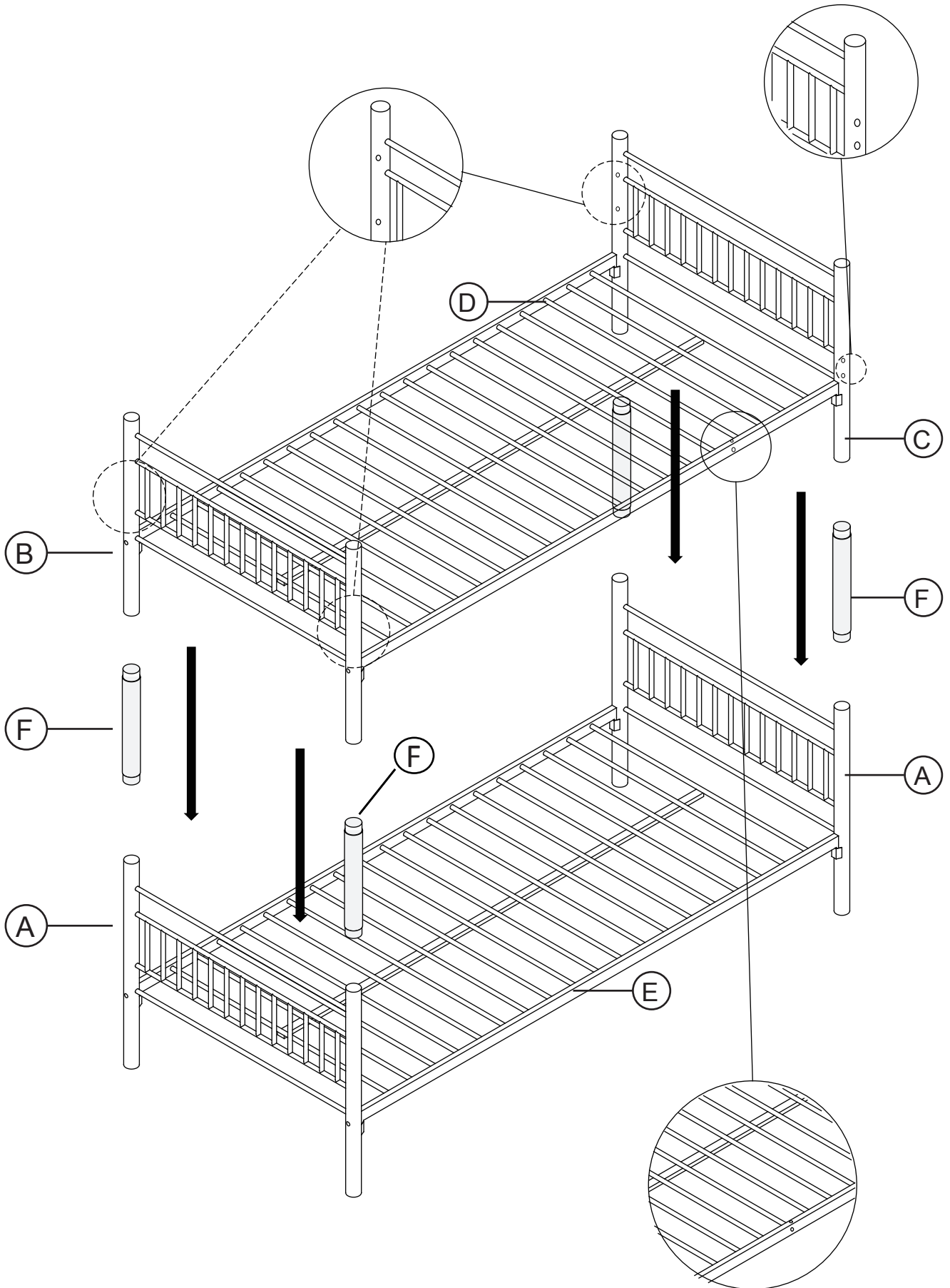

Step 4

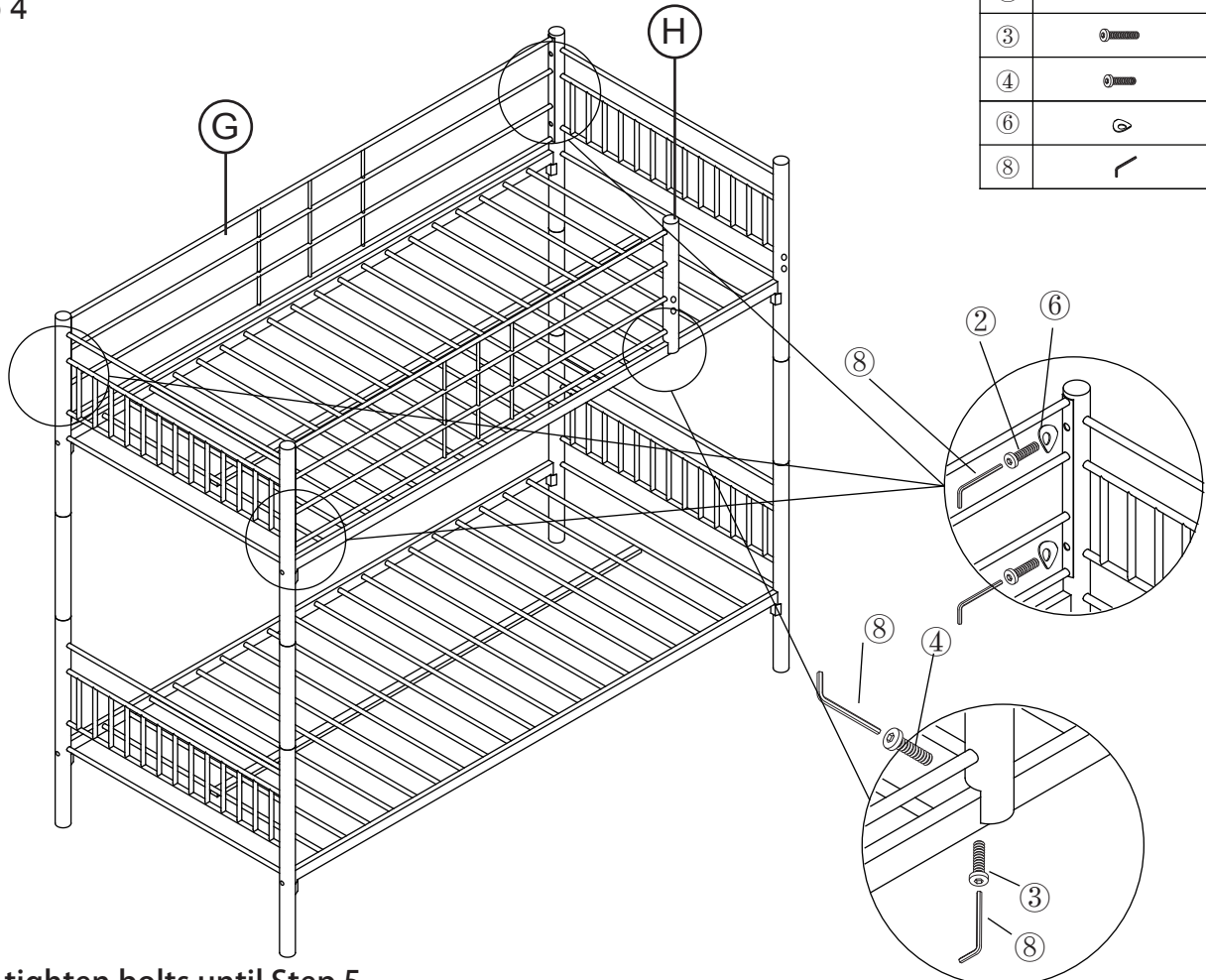

②		6
③		1
④		1
⑥		6
⑧		1

Do not tighten bolts until Step 5.

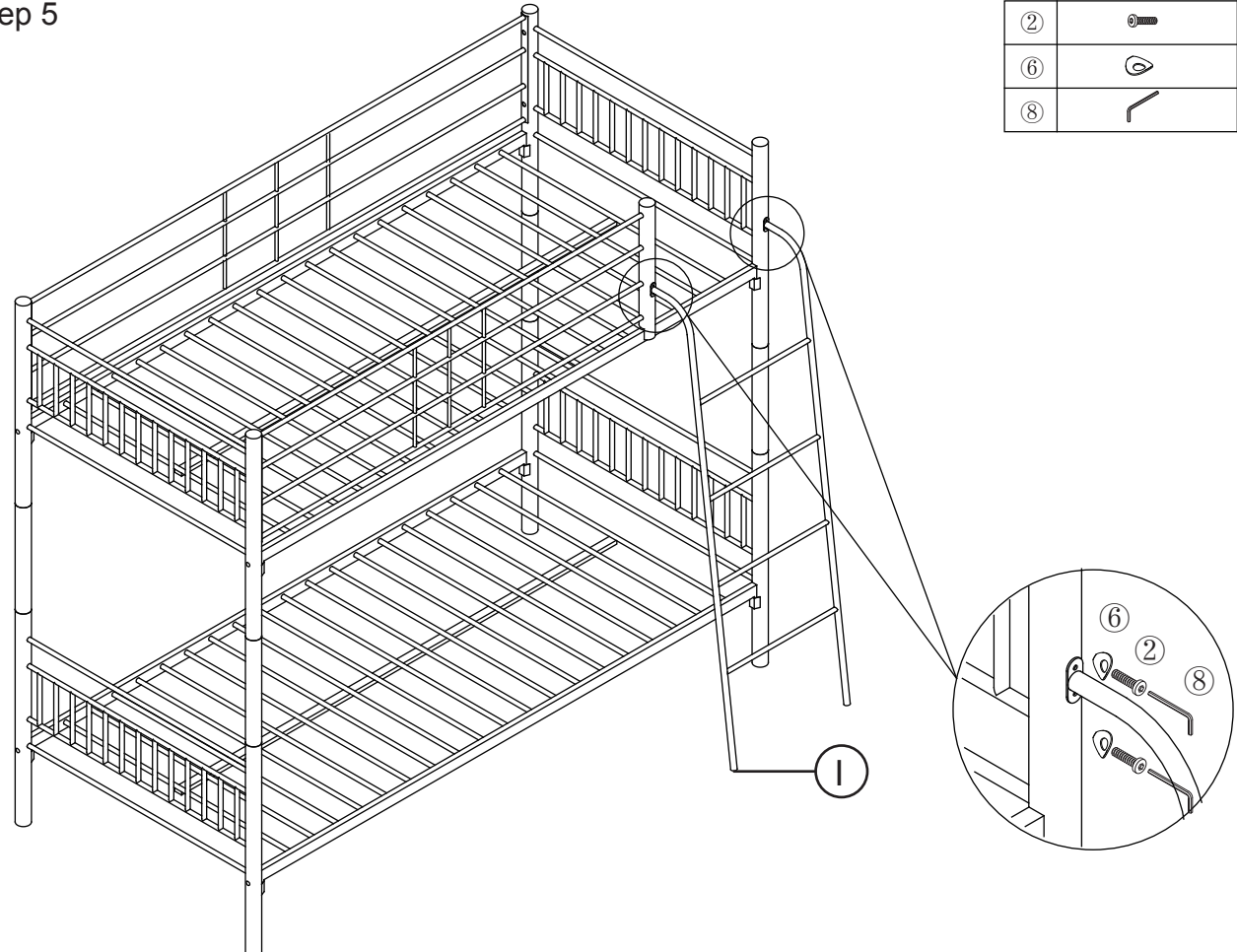

Step 5



②		4
⑥		4
⑧		1

Tighten all bolts at this step.

Step 6

⑨		2
⑦		8

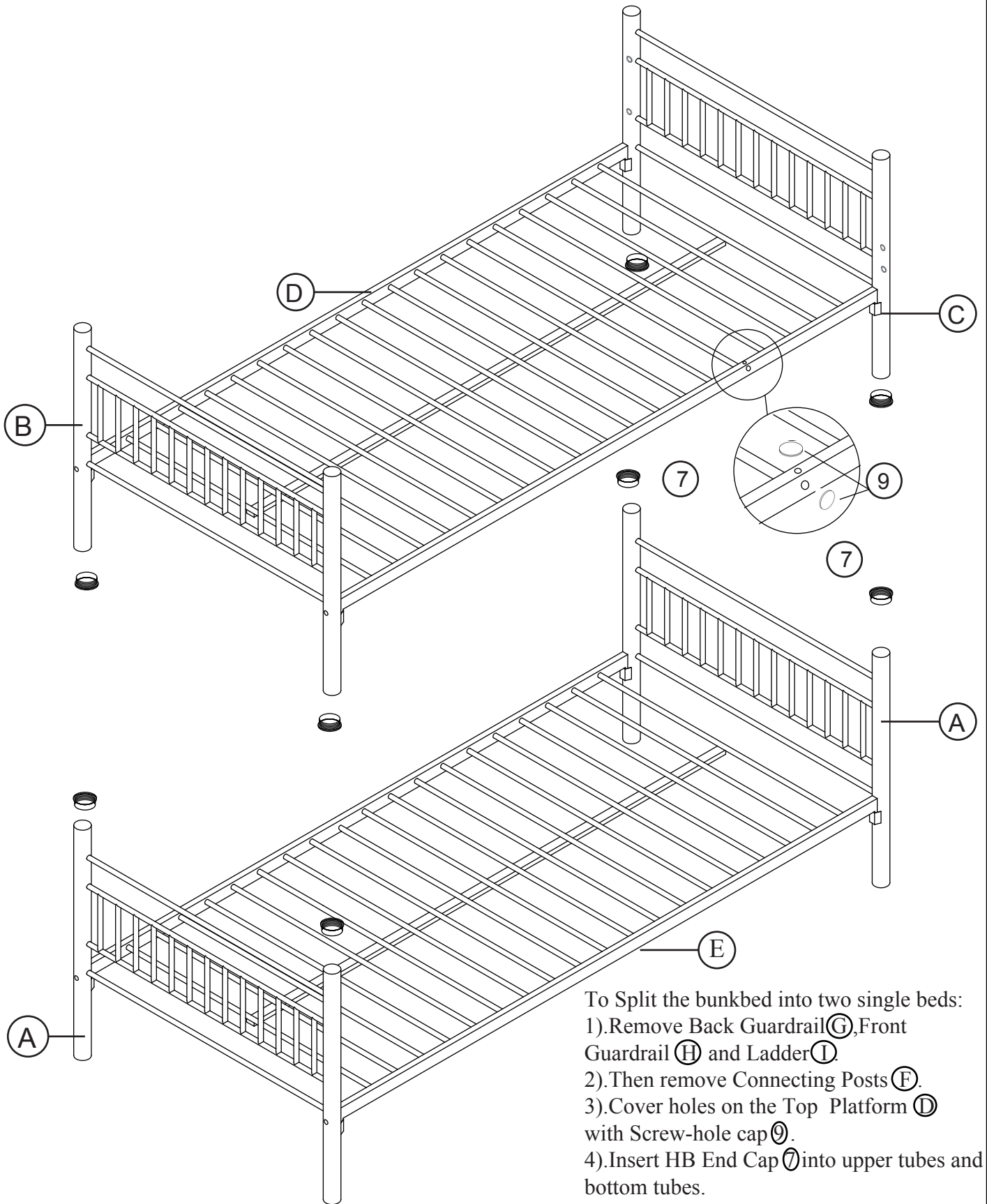

To Split the bunkbed into two single beds:
 1). Remove Back Guardrail (G), Front Guardrail (H) and Ladder (I).
 2). Then remove Connecting Posts (F).
 3). Cover holes on the Top Platform (D) with Screw-hole cap (9).
 4). Insert HB End Cap (7) into upper tubes and bottom tubes.

WARNING

TO HELP PREVENT SERIOUS OR FATAL

INJURIES FROM ENTRAPMENT OR FALLS

- . Never allow a child under 6 years on upper bunk
 - . Use only mattress which is 74" -75"long
 - and 37¹/₂"- 38¹/₂" wide on upper bunk

- . Ensure thickness of mattress does not exceed 7" and mattress is at least 5" below upper edge of guardrails

- . Use guardrails on both sides of upper bunk

- . Prohibit horseplay on or under bed(s)

- . Prohibit more than one person on the upper bunk

- . Use ladder for entering and leaving upper bunk

STRANGULATION HAZARD- Never attach or hang items to any part of the bunk bed that are not designed for use with the bed ;for example, but not limited to ,hooks, belts, and jump ropes

DO NOT REMOVE THIS LABEL