

ASSEMBLY INSTRUCTIONS

Style # T999 & T998 TABLE SETS

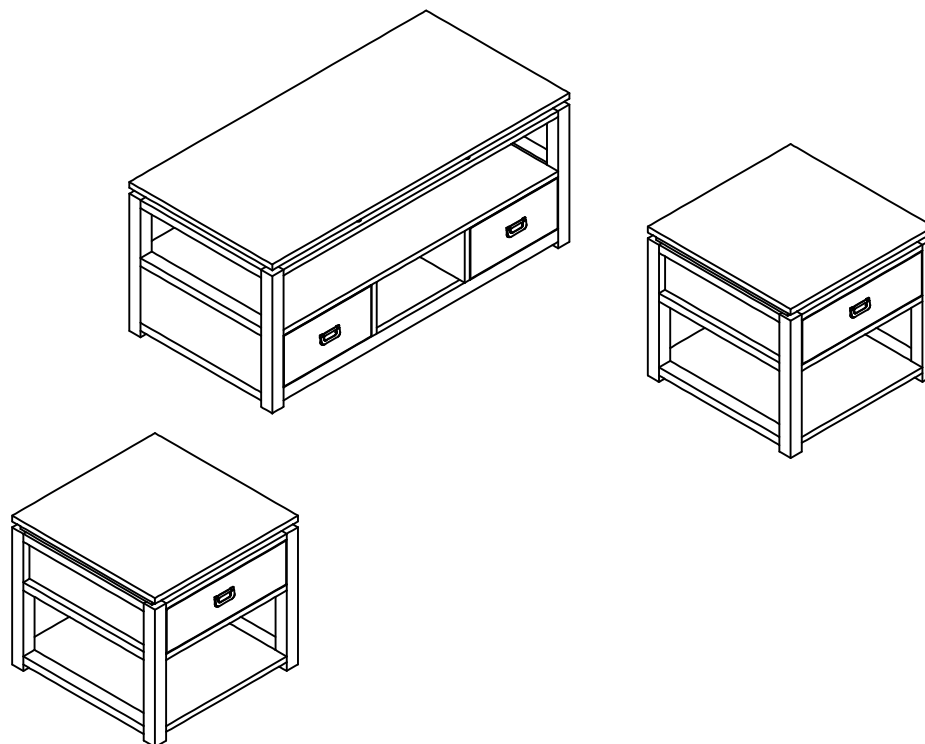

NOTE TO CUSTOMERS:

- For ease and speed of assembly we recommend that before you commence each step of the assembly that you identify all the parts required to complete that step.
- We recommend that where possible you allow sufficient space to assemble the item as close as possible to the place where it will be once assembled.
- For the protection of your furniture we recommend that the product is placed on protected surfaces during assembly to prevent any damage.
- During assembly do not over tighten, as this may damage the product.
- Please ensure you retain all the product packaging until the item completely assembled.
- Please periodically check all fittings and re-tighten as necessary.
- It is recommended that this item should be assembled by two adults.

To insert a cam lock: (Please read below instructions before assembling)





	<p>Diagram A</p>	<p>1. Insert cam screw into hole as shown in diagram A .</p>
	<p>Diagram B</p>	<p>Make sure not to insert the cam screw: Too deep as shown in figure B as this will cause the cam screw to be misaligned and unable to interlock properly.</p>
	<p>Diagram C</p>	<p>Also avoid inserting the cam screw too close to the surface of the hole as shown in figure C, as this will cause the cam lock to be too loose, and not interlock properly.</p>

	<p>2. Connect the panels together.</p>
<p>ARROW SIGN</p>	<p>3. When inserting the cam lock make sure the arrow of the cam lock faces the cam screw.</p>
	<p>4. To tighten the cam lock turn the cam lock clockwise 90-180 degree or until the arrow is facing opposite the place cam lock was inserted.</p> <p>NOTE: DO NOT USE AN AUTOMATIC SCREWDRIVER TO TIGHTEN CAM LOCKS.</p>



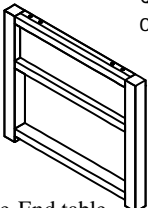
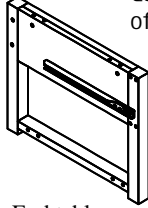
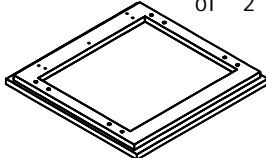
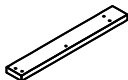

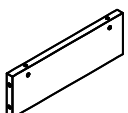
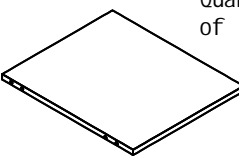
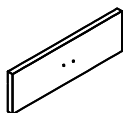
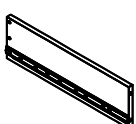
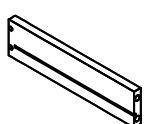
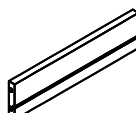
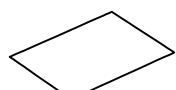
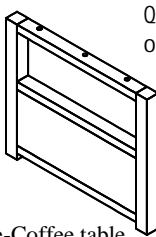
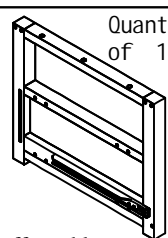
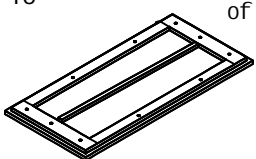
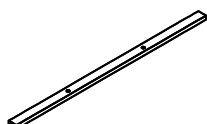
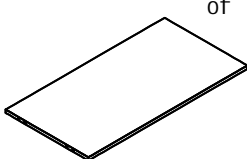
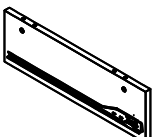
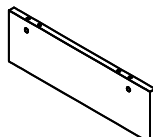
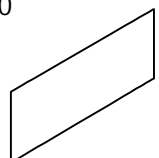
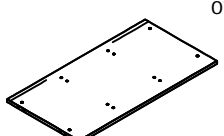
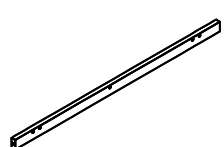

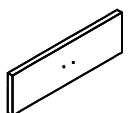
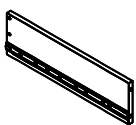
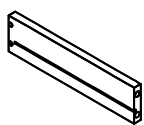
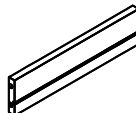
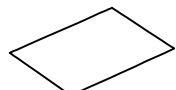
Note:

- Read these instructions carefully before assembling.
- Tools required : Phillips screwdriver, flat screwdriver.
- Find a clean, smooth area on which to work , such as a carpet, in order to avoid scratching the wood surfaces.
- Wait to dispose of the packing material until assembly is complete and all parts and hardware are accounted for.
- Two or more people might be required for assembly.

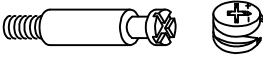
Part List

<p>1</p>  <p>Quantity of 2</p> <p>Left frame-End table</p>	<p>2</p>  <p>Quantity of 2</p> <p>Right frame-End table</p>	<p>3</p>  <p>Quantity of 2</p> <p>Top Panel-End table</p>	<p>4</p>  <p>Quantity of 2</p> <p>Rear Apron-End table</p>
<p>5</p>  <p>Quantity of 4</p> <p>Front Apron-End table</p>	<p>6</p>  <p>Quantity of 2</p> <p>Back Panel-End table</p>	<p>7</p>  <p>Quantity of 2</p> <p>Shelf -End table</p>	<p>8</p>  <p>Quantity of 2</p> <p>Drawer front Panel -End table</p>
<p>9</p>  <p>Quantity of 2</p> <p>Drawer Left Side Panel-End table</p>	<p>10</p>  <p>Quantity of 2</p> <p>Drawer Right Side Panel-End table</p>	<p>11</p>  <p>Quantity of 2</p> <p>Drawer Back Panel-End table</p>	<p>12</p>  <p>Quantity of 2</p> <p>Drawer Bottom Panel-End table</p>
<p>13</p>  <p>Quantity of 1</p> <p>Left frame-Coffee table</p>	<p>14</p>  <p>Quantity of 1</p> <p>Left frame-Coffee table</p>	<p>15</p>  <p>Quantity of 1</p> <p>Top Panel-Coffee table</p>	<p>16</p>  <p>Quantity of 2</p> <p>Upper Apron-Coffee table</p>
<p>17</p>  <p>Quantity of 1</p> <p>Shelf-Coffee table</p>	<p>18</p>  <p>Quantity of 1</p> <p>Divider-Coffee table</p>	<p>19</p>  <p>Quantity of 1</p> <p>Divider-Coffee table</p>	<p>20</p>  <p>Quantity of 2</p> <p>Back Panel-Coffee table</p>
<p>21</p>  <p>Quantity of 1</p> <p>Bottom Panel-Coffee table</p>	<p>22</p>  <p>Quantity of 1</p> <p>Lower Apron-Coffee table</p>	<p>23</p>  <p>Quantity of 1</p> <p>Center Leg-Coffee table</p>	<p>24</p>  <p>Quantity of 1</p> <p>Drawer Front Panel-Coffee table</p>
<p>25</p>  <p>Quantity of 1</p> <p>Drawer Left Panel-Coffee table</p>	<p>26</p>  <p>Quantity of 1</p> <p>Drawer Right Panel-Coffee table</p>	<p>27</p>  <p>Quantity of 1</p> <p>Drawer Back Panel-Coffee table</p>	<p>28</p>  <p>Quantity of 1</p> <p>Drawer Bottom Panel-Coffee table</p>

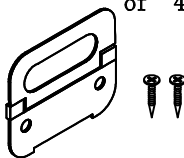
Hardware List

<p>A</p> <p style="text-align: center;">Quantity of 71</p>  <p>Cam-Lock</p>	<p>B</p> <p style="text-align: center;">Quantity of 52</p>  <p>Wood Dowel</p>	<p>C</p> <p style="text-align: center;">Quantity of 14</p>  <p>Screw</p>	<p>D</p> <p style="text-align: center;">Quantity of 8</p>  <p>Screw</p>
<p>E</p> <p style="text-align: center;">Quantity of 8</p>  <p>Plastic Connect Block</p>	<p>F</p> <p style="text-align: center;">Quantity of 4</p>  <p>Handle with Screw</p>	<p>G</p> <p style="text-align: center;">Quantity of 4</p>  <p>Bolt</p>	<p style="text-align: center;">Quantity of 1</p>  <p>Allen Wrench</p>

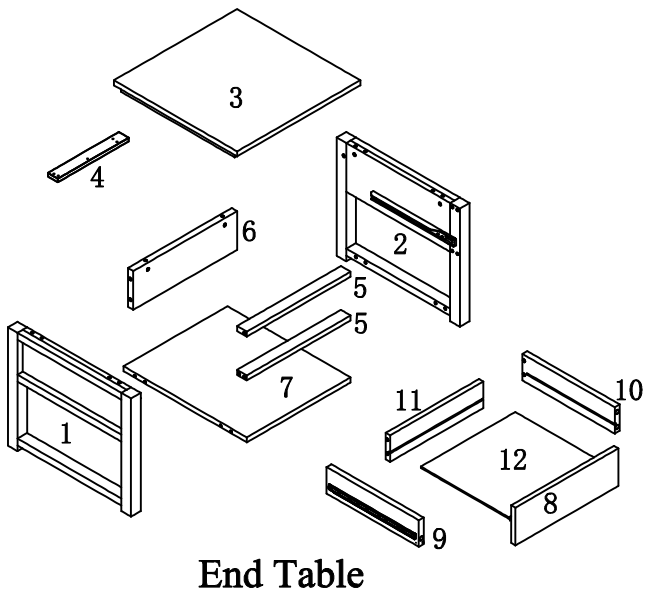

End Table

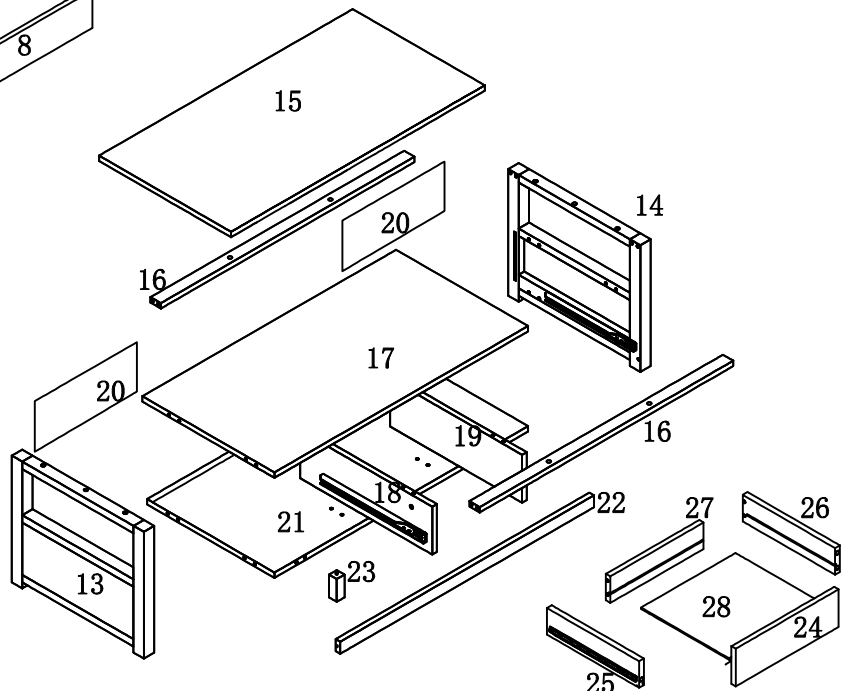

Coffee Table

Assembly Instruction

- | | |
|----|--------|
| A: | 12sets |
| B: | 8pcs |

Step 1:

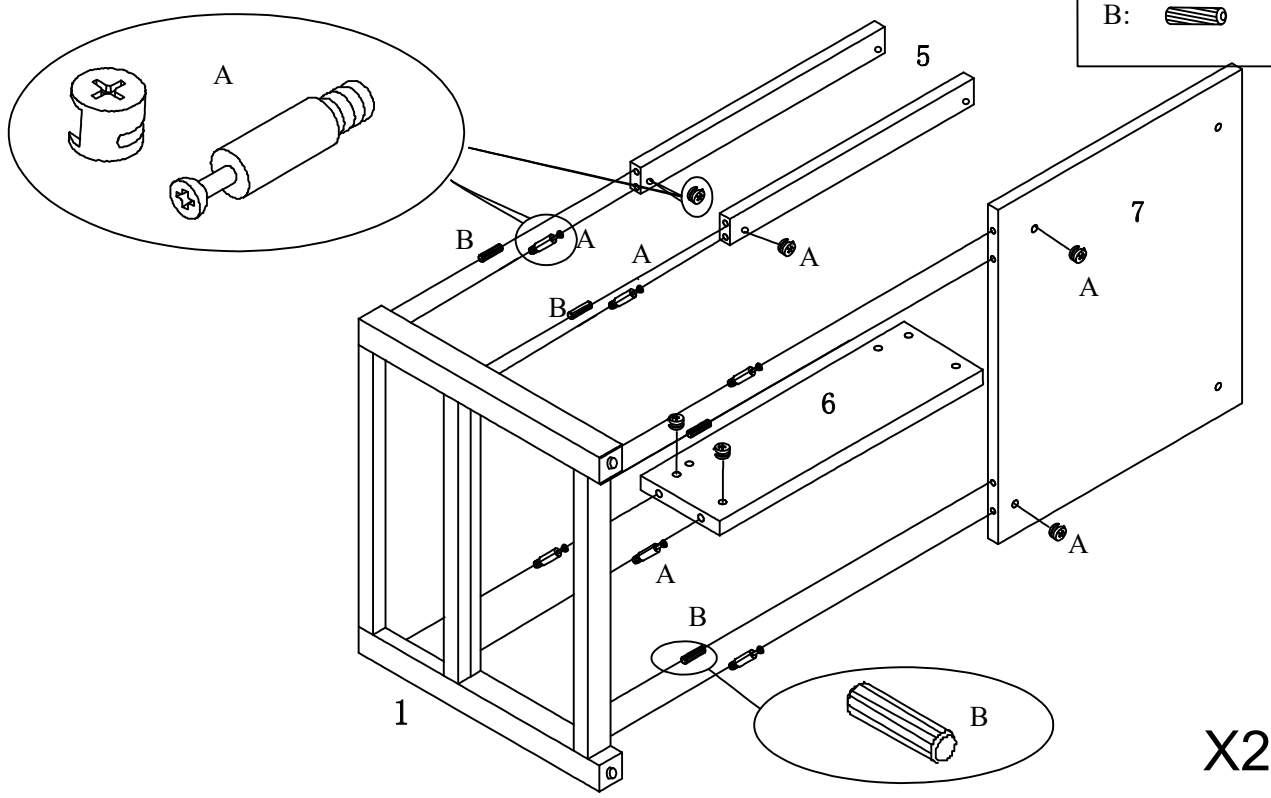

Assemble Front Aprons (5), Back Panel (6) and Shelf (7) to Left Frame (1) using Camlocks(A) & Wood Dowels (B) as shown above.

Step 2:

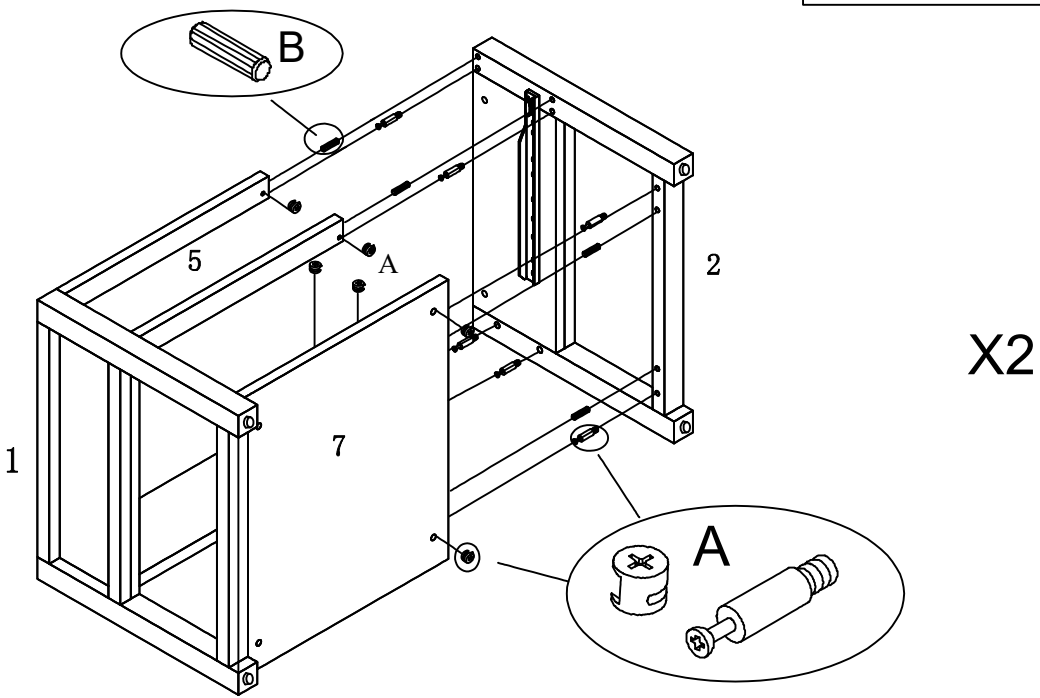

- | | |
|----|--------|
| A: | 12sets |
| B: | 8pcs |

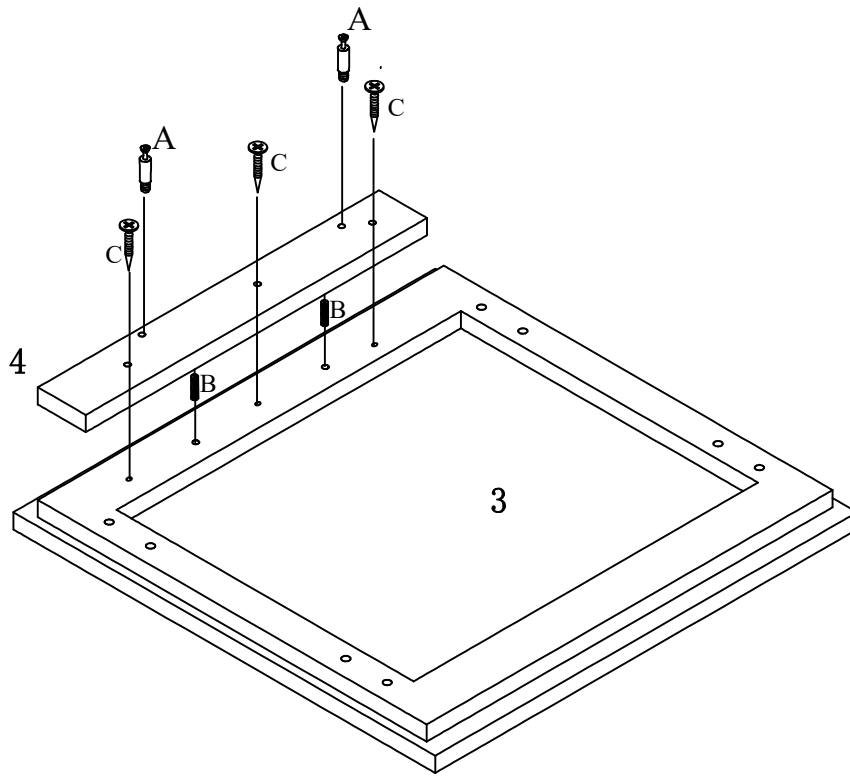

Assemble Front Aprons (5), Back Panel (6) and Shelf (7) to Right Frame (2) using Camlocks(A) & Wood Dowels (B) as shown above.

Step 3:







A:		4pcs
B:		4pcs
C:		6pcs

X2

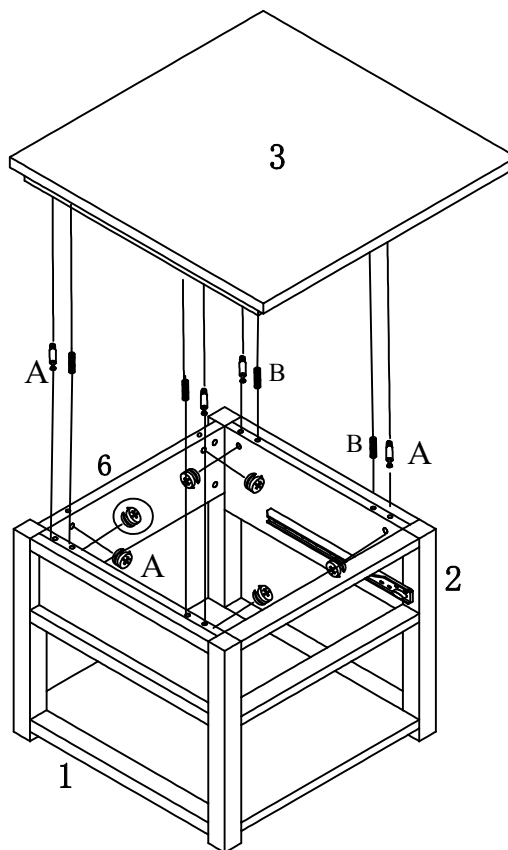
Assemble Rear Apron (4) to the bottom of top panel (3) using Camlocks(A) & Wood Dowels (B), Screws (C) as shown above.

Step 4:



A:		8pcs
A:		12pcs
B:		8pcs

X2

Assemble Top Panel (3) to Left & Right Frame (1) (2) & Back Panel (6) using Camlocks(A) & Wood Dowels (B) as shown above.

Step 5:

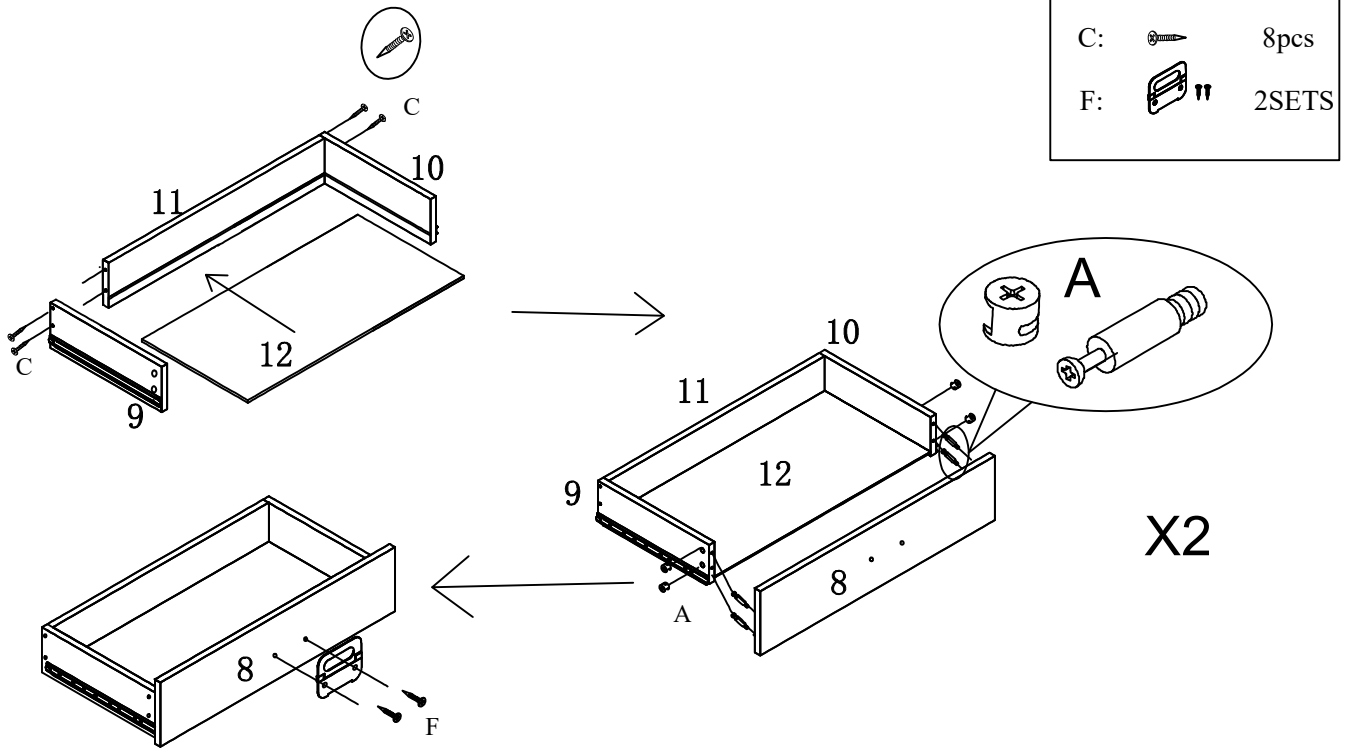

Assemble Drawer Side Panels (9) & (10) to Drawer Back Panel (11) using Screws(C).
 Insert Drawer Bottom Panel (12) into grooves on Drawer Side Panels(9) &(10).
 Attach Drawer Front Panel(8) to Drawer Side Panels(9) &(10) using Camlocks (A) .
 Attach Handle (F) to Drawer Front Panel (8)using included screws.

Step 6:

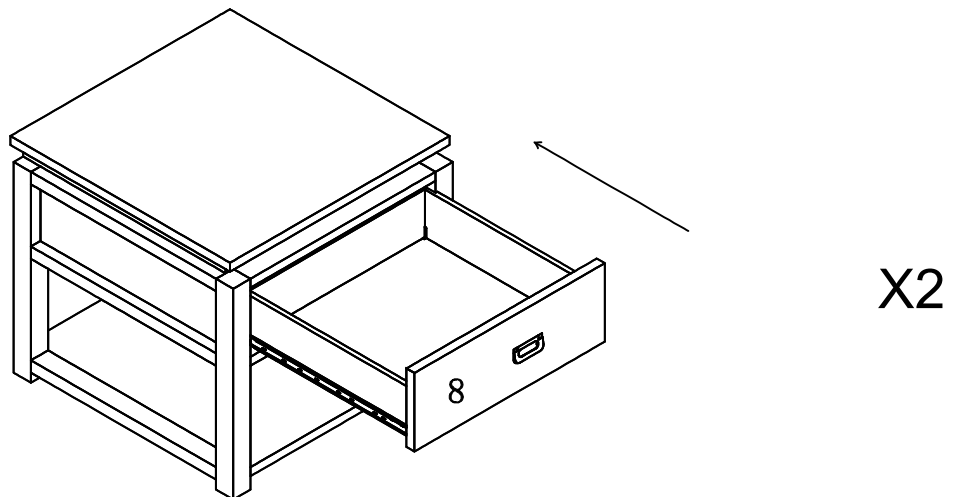

Insert the drawer into the cabinet of end table as shown above.

Step 7:

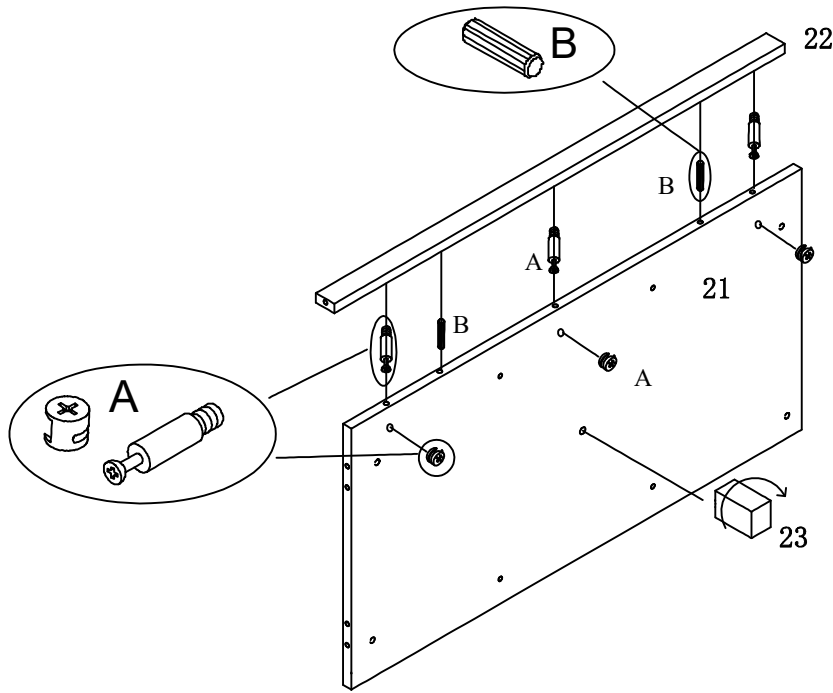

A:  3sets

B:  2pcs

Assemble Lower Apron (22) to Bottom Panel(21) using Camlocks(A) & Wood Dowels (B) as shown above. Then tighten Center Leg(23) to the bottom of bottom panel (21).

Step 8:

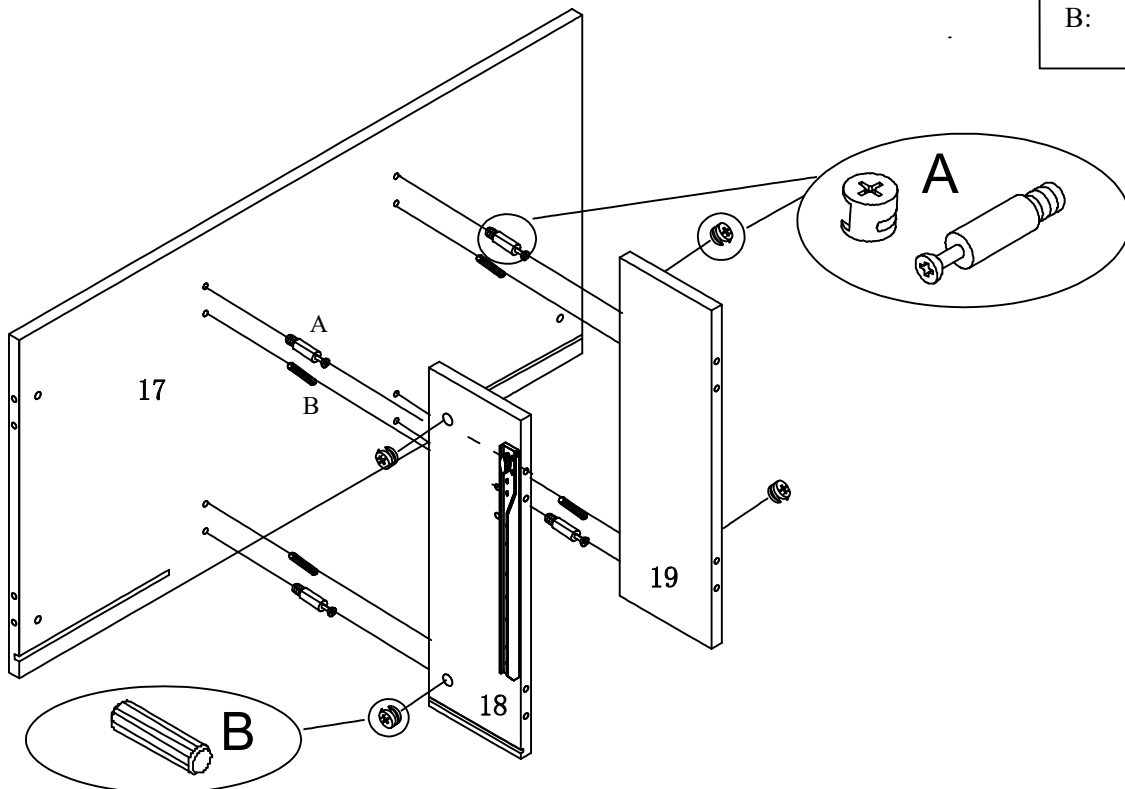

A:  4sets

B:  4pcs

Assemble Dividers (18) & (19) to Shelf (17) using Camlocks(A) & Wood Dowels (B) as shown above.

Step 9:

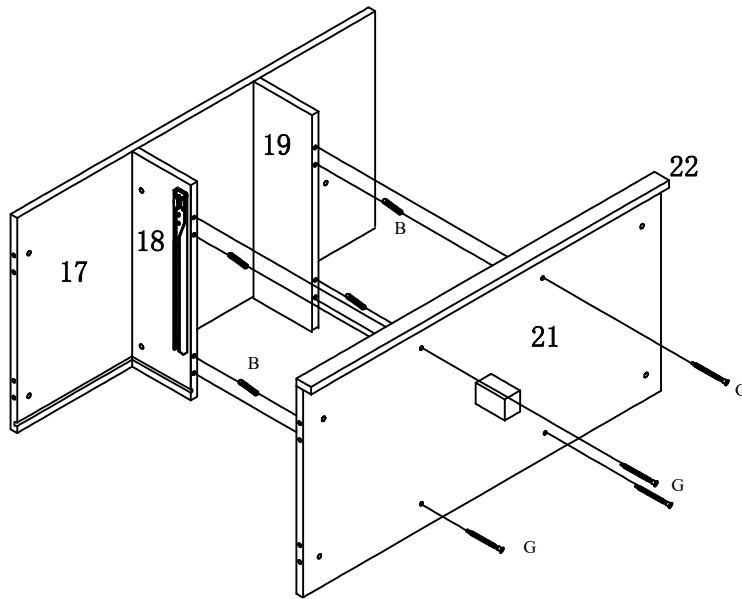
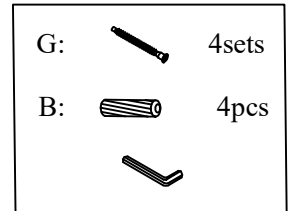

Assemble Bottom Panel(21) to Dividers (18) &(19) using Wood Dowels (B) & Screws (G) as shown above.

Step 10:

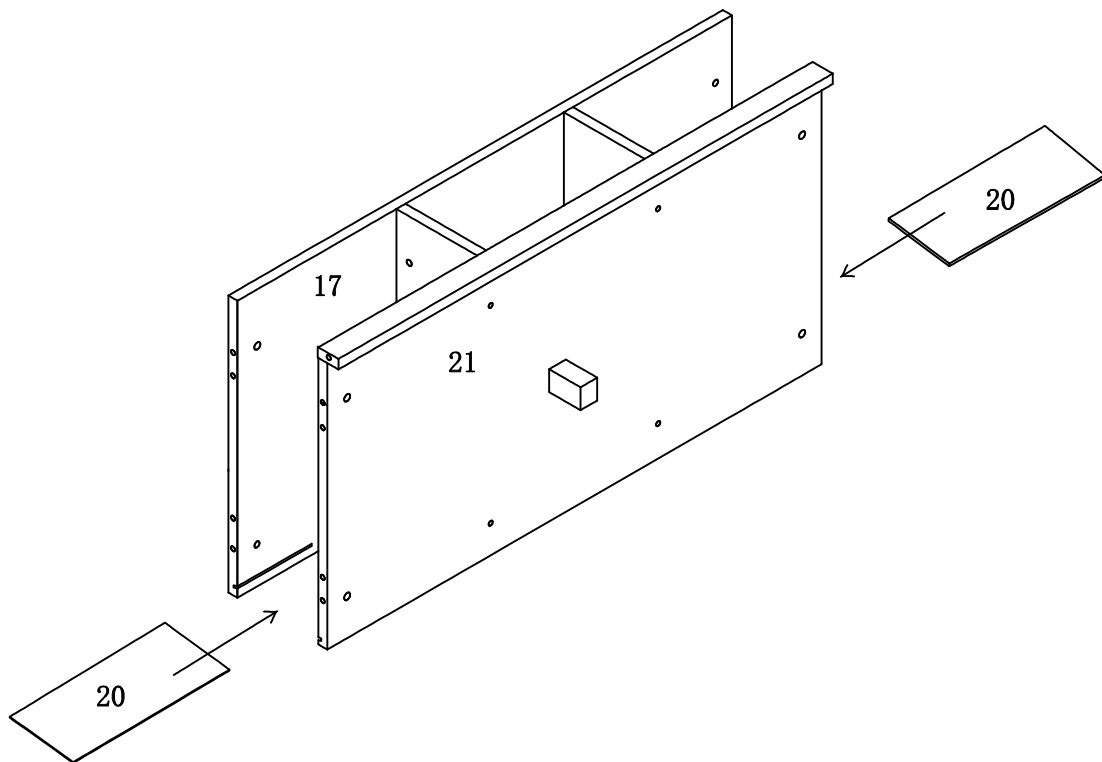

Insert Back Panels (20) into grooves on Shelf (17) & Bottom Panel (21) as shown above.

Step 11:

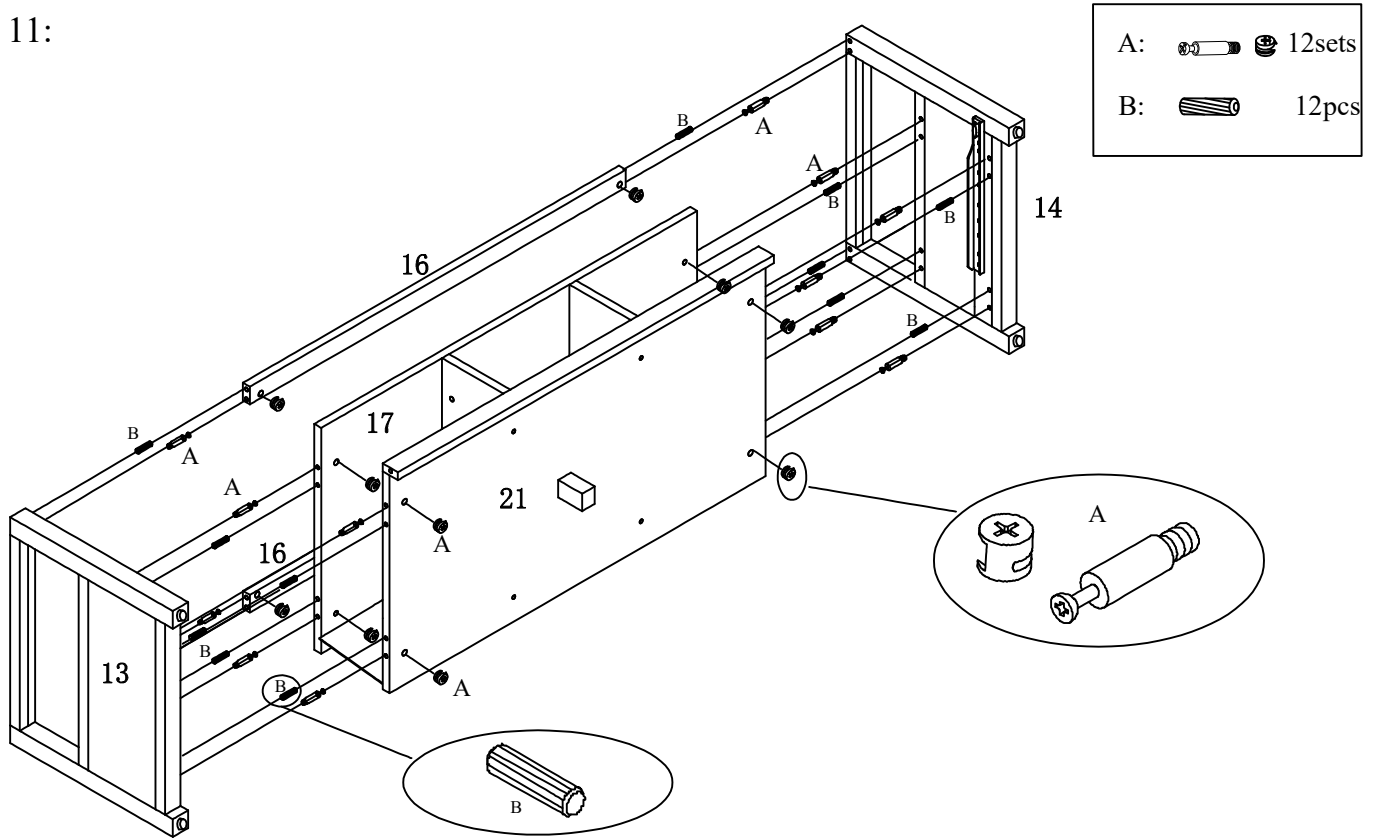

Assemble Left & Right Frame(13) &(14) to Bottom Panel(21) , Shelf (17) and Upper Aprons (16) using Camlocks (A) & Wood Dowels (B) as shown above.

Step 12:

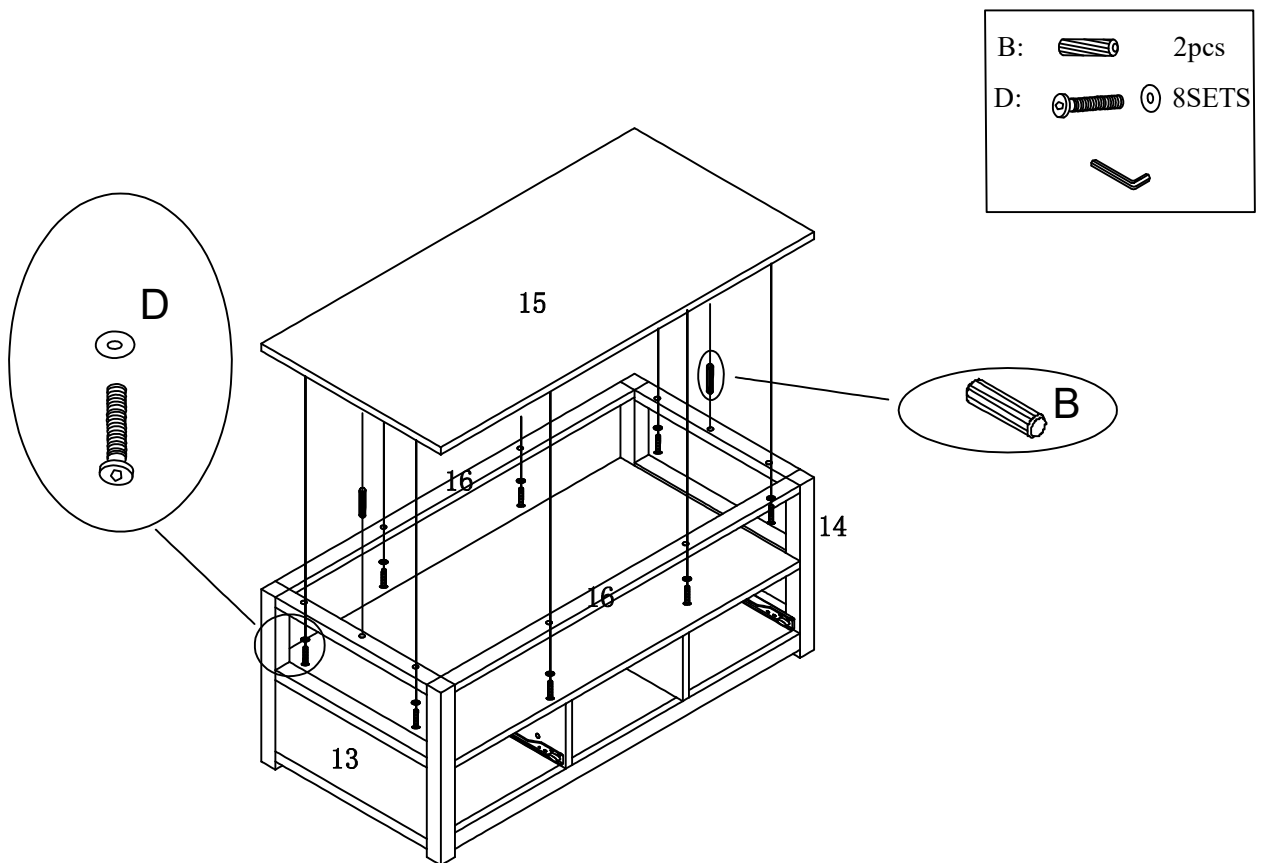

Assemble Top Panel (15) to Side Frames (13) &(14), Upper Aprons(16) using Wood Dowels (B) & Bolts with washers (D) as shown above.

Step 13:

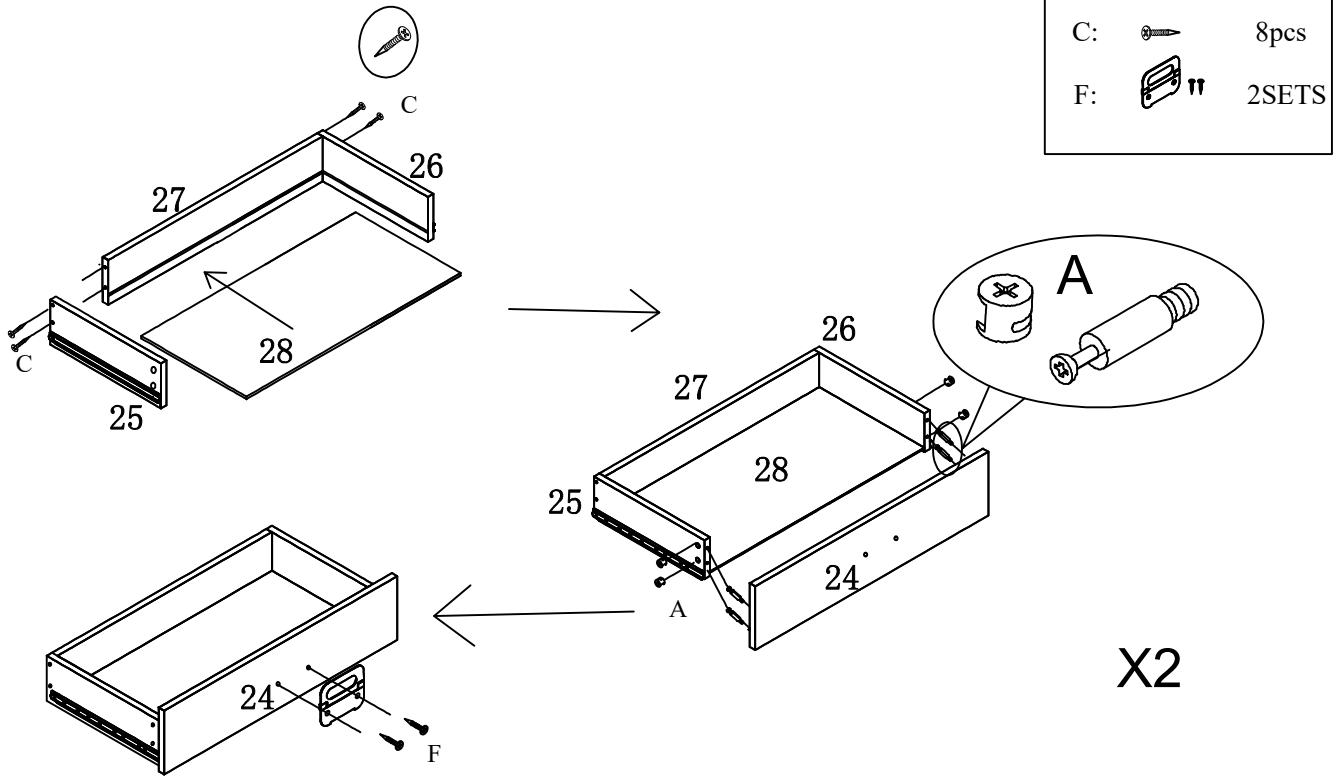

Assemble Drawer Side Panels (25) & (26) to Drawer Back Panel (27) using Screws(C).
 Insert Drawer Bottom Panel (28) into grooves on Drawer Side Panels(25) &(26).
 Attach Drawer Front Panel(24) to Drawer Side Panels(25) &(26) using Camlocks (A) .
 Attach Handle (F) to Drawer Front Panel (24)using included screws.

Step 14:

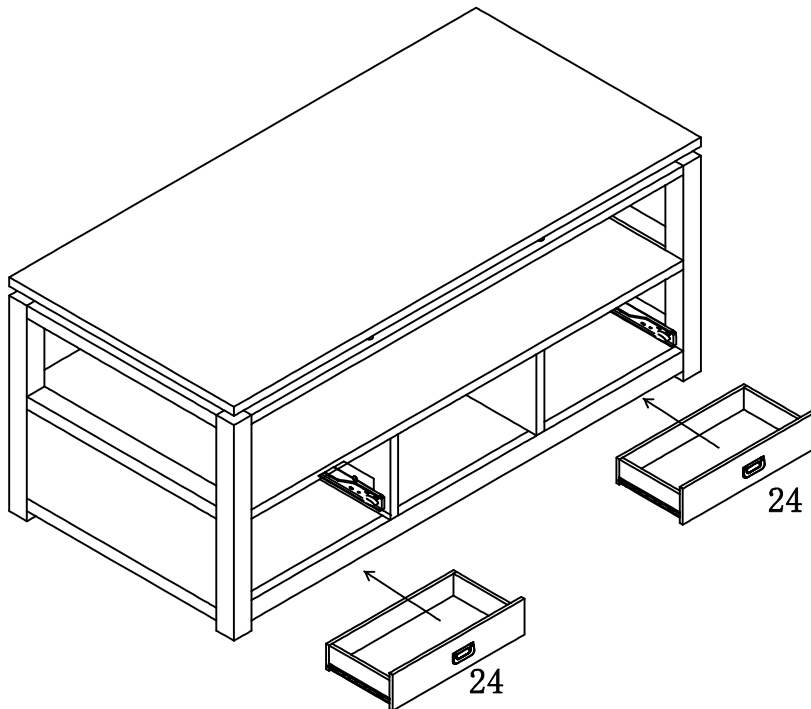

Insert the drawer into the cabinet of coffee table as shown above.

Step 15:

E:   8sets

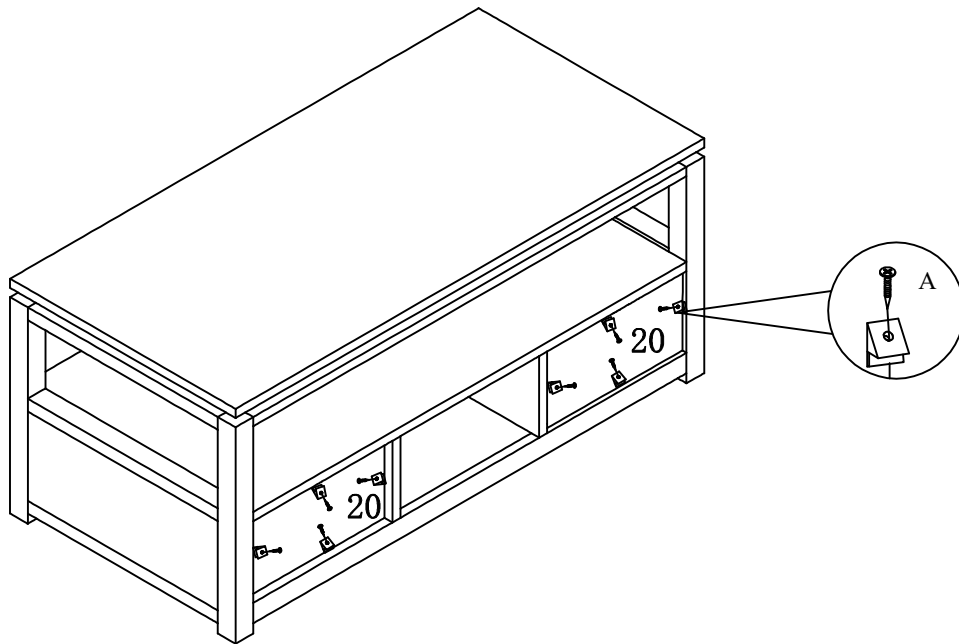

Attach Plastic Connect Blocks (E) to Bottom Panel (21) to hold Back Panel (20) & Dividers (18) &(19), Shelf (17) using included Screws as shown above.

