

ASSEMBLY INSTRUCTIONS

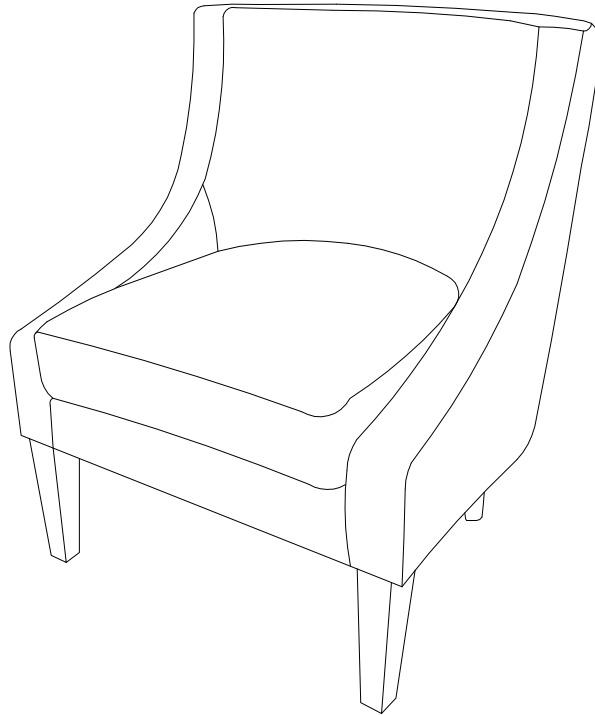

Style # AC6299 Accent Chair



NOTE TO CUSTOMERS:

- For ease and speed of assembly we recommend that before you commence each step of the assembly that you identify all the parts required to complete that step.
- We recommend that where possible you allow sufficient space to assemble the item as close as possible to the place where it will be once assembled.
- For the protection of your furniture we recommend that the product is placed on protected surfaces during assembly to prevent any damage.
- During assembly do not over tighten, as this may damage the product.
- Please ensure you retain all the product packaging until the item completely assembled.
- Please periodically check all fittings and re-tighten as necessary.
- It is recommended that this item should be assembled by two adults.

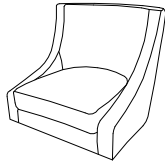
Part List:

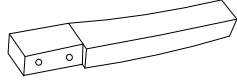
	DRAWING	DESCRIPTION	Q'ty
A1		Seat	1PC
A2		Front Legs	2PCS
A3		Rear Legs	2PCS

Hardware List:

	DRAWING	DESCRIPTION	Q'ty
B1		Bolt	8PCS
B2		Flat Washer	8PCS
B3		Spring Washer	8PCS
B4		Allen Key	1PC

APPENDIX: Dimension of Hardware in this AI

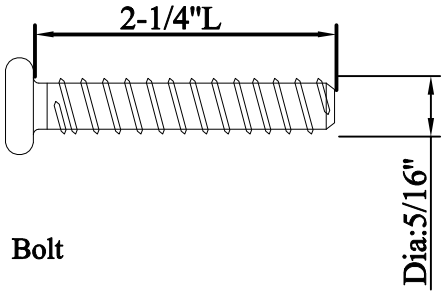
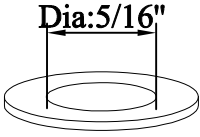
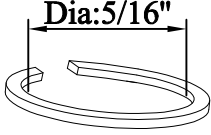
 <p>Bolt</p>	 <p>Flat Washer</p>	 <p>Spring Washer</p>
---	---	--

STEP 1

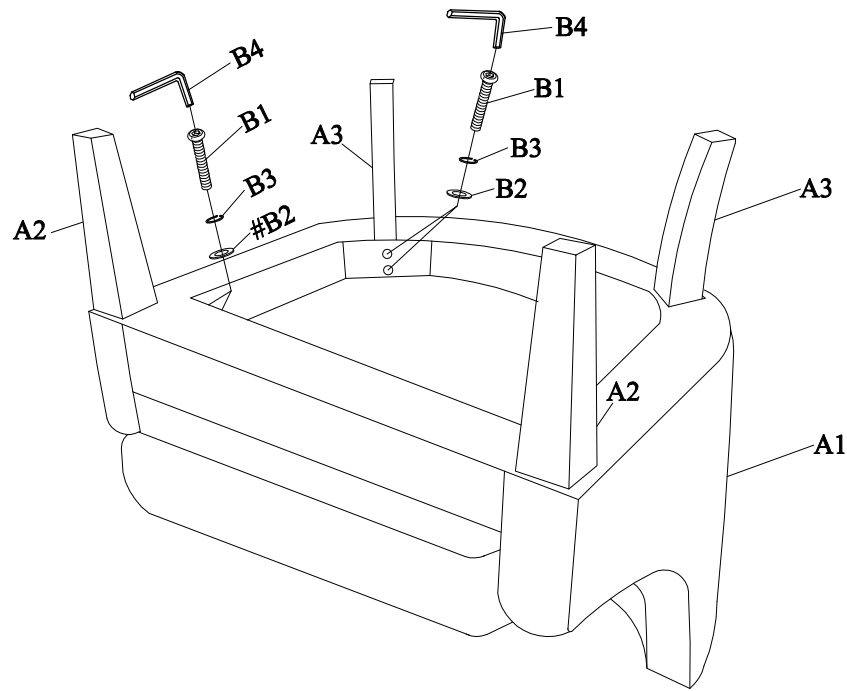

Attach Front Legs A2 and Rear Legs A3 to the bottom of Seat A1 using Bolts B1 with Flat Washers B2 & Spring Washers B3 as shown above, do not tight bolts until all bolts until Step 2.

STEP 2

Place the chair on the floor to check if it is stable before tightening all of bolts.

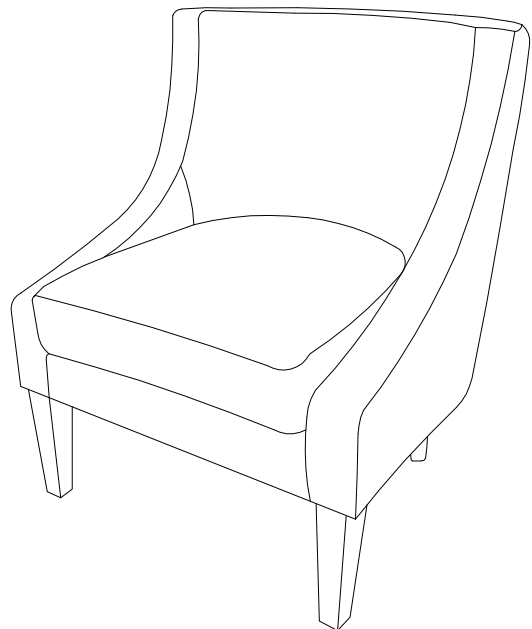

Warning:

Do not stand on the chair, do not use it as a step ladder.

Do not use knife to open any parts of the box of chair.

Please ensure all bolts and screws are firmly secured before using this chair.

Chair Assembly Tips

The key to correct chair assembly is to loosely attach all of the bolts, then gradually tighten them in succession until all of them are secure. Completely tightening one or more bolts prematurely can result in the following:

ISSUE: CHAIR IS UNLEVELED

Cause:

- Chairs can be wobbly or unlevelled if one or more bolts are fully tightened before all bolts are attached and/or tightened.
- Chairs can be wobbly or unlevelled if assembly is completed in a different room or surface than where the product is intended to primarily reside.

Solution:

- Loosen each bolt in the seat box (front legs, back corner-blocks, and back apron) until they are adjustable by hand. Place the chair upright on the floor. Press firmly and evenly on the seat edges until the product sits level but do not lean against the chair back. Once the chair sits level on the desired surface, fully tighten each bolt.
- When assembling your chair, make sure to do it in the location that the chair will most often be used. Uneven flooring frequently accounts for wobbling issues.

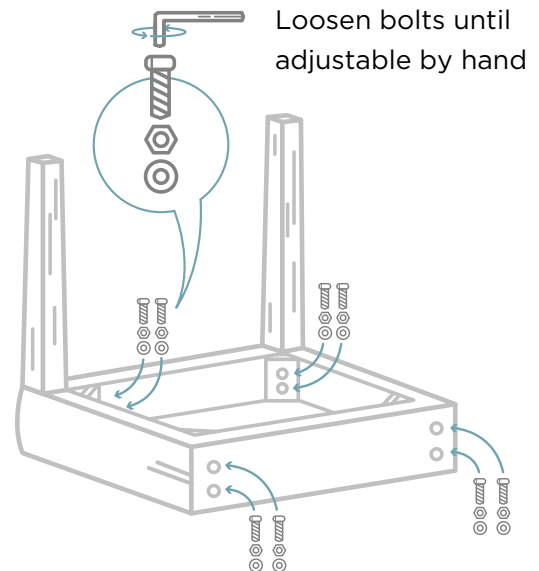

ISSUE: HOLES ARE MISALIGNED

Cause:

- This issue can occur when some bolts are tightened fully before all other bolts are tightened or attached.

Solution:

- Loosen each bolt in the seat box (front legs, back corner-blocks, and back apron) until finger tight. This will allow you to realign the holes and properly fasten the bolts to the frame.